

# Kälteplan WLW286.2-22 / CS5001AW 22

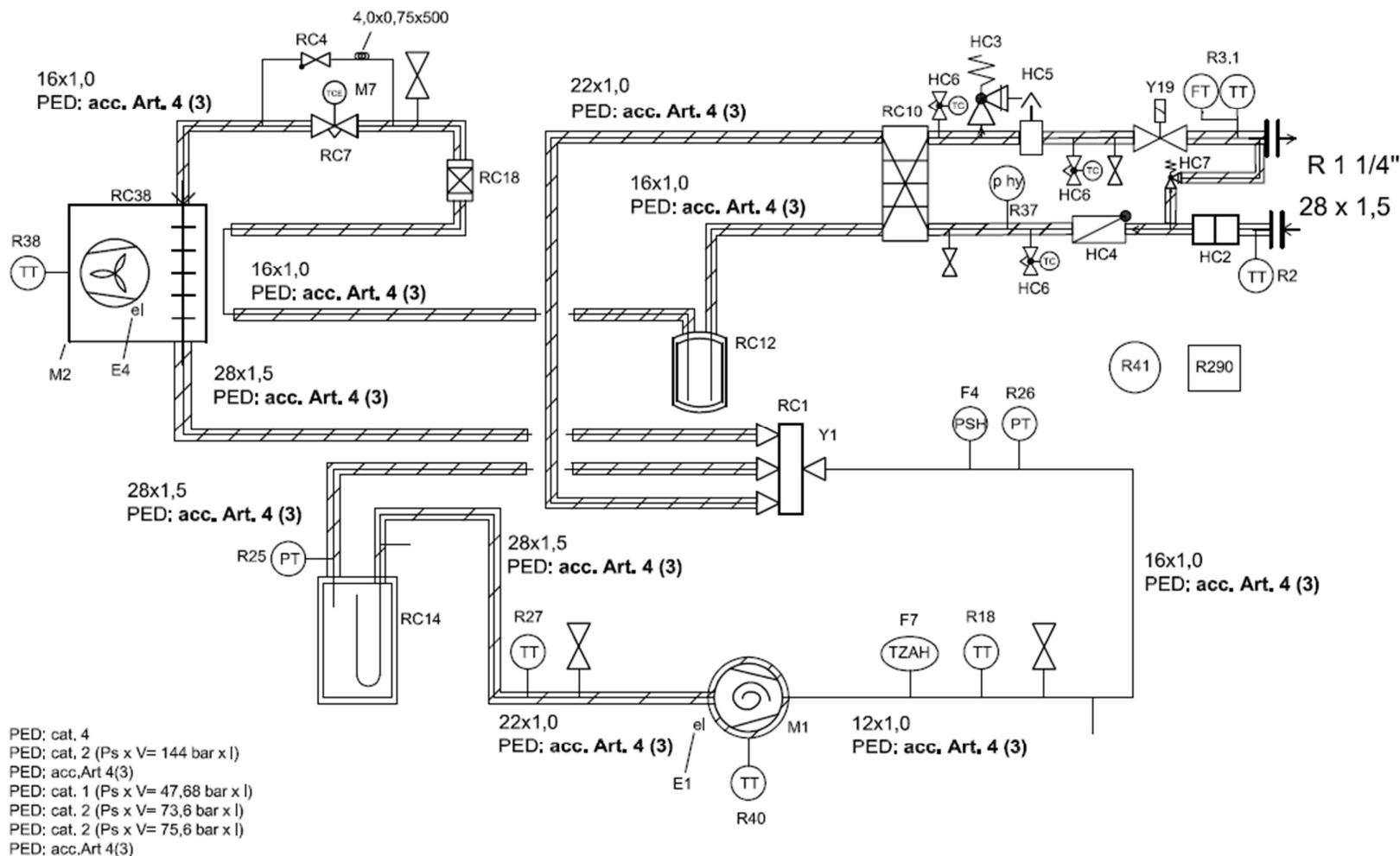

Revision: B

4521736401

## Kälteplan

### WLW286.2-22 / CS5001AW 22

E1	Ölsumpfheizung	crankcase heater
E4	Düsenringheizung	nozzle ring heater
F4	HD Pressostat	high pressure switch
F7	Heißgasthermostat	high temperature switch
HC2	Schmutzfilter	dirt separator
HC3	Sicherheitsventil	safety valve
HC4	Rückschlagventil	check valve
HC5	Luftabscheider	air separator
HC6	Frostschutzventil	anti freeze valve
HC7	Überströmventil	overflow valve
M1	Verdichter	compressor
M2	Ventilator	fan
M7	Ex-Ventil Spule	exp.-valve coil
R18	Temperaturfühler Heißgas	temperature sensor hot gas
R2	Temperaturfühler Rücklauf	temperature sensor water inlet
R25	Drucksensor p0	low pressure sensor
R26	Drucksensor pc	high pressure sensor
R27	Temperaturfühler Sauggas	temperature sensor suction gas
R3.1	Durchflusssensor und Temperaturfühler Vorlauf	flow sensor with temperature sensor water outlet
R37	Ducksensor Heizwasser	pressure sensor heating water
R38	Temperaturfühler Lufteintritt	air inlet temperature sensor
R40	Temperaturfühler Ölsumpf	temperature sensor crankcase
R41	Gas Sensor Propan	gas sensor propane
RC1	4WUV	4-way-valve
RC4	Rückschlagventil	check valve
RC7	Ex-Ventil Körper	exp.-valve body
RC10	Plattenwärmetauscher	Plate heat exchanger
RC12	Sammler	liquid receiver
RC14	Abscheider	suction accumulator
RC18	Filtertrockner	filter dryer
RC38	Lamellenwärmetauscher	finned heat exchanger
Y1	4WUV-Spule	4-way-valve coil
Y19	Magnetventil NC	solenoid valve NC