

**General Service Manual**

**230 V 1 N~/400 V 3 N~**

# **A/W 2000 Full Monoblock**

## **Series (4~16kW and 18~30kW)**



**ODU 4kW/ 6kW/ 8kW /10kW /12kW /14kW /16kW 230V – R32**

**ODU 12kW /14kW /16kW 400V – R32**

**ODU 18kW/ 22kW/ 26kW /30kW 400V – R32**

## Introduction

Dear Customer,  
Congratulations for choosing this product.

The aim of this manual is to provide information that is useful throughout all phases - from reception to installation and use, right through to disposal - so that such an advanced system can provide the best performance during installation and use.

Best regards and happy reading.

## Symbols used in the manual and their meaning



---

### WARNING

To indicate particularly important and sensitive information and operations.

---



---

### CAUTION DANGER

To indicate actions which, if not carried out correctly, may result in serious accidents or may cause malfunctions or material damage to the appliance; therefore, they require special attention and adequate preparation.

---



# Index

<b>1. Safety considerations</b>		
1.1 Safety	6	
1.2 Manual	6	
1.3 Situations of Risk	6	
1.4 Intended use	6	
1.5 Installation	6	
1.6 Maintenance	7	
1.7 Changes	7	
1.8 Fault or malfunction	7	
1.9 User training	7	
1.10 Data updating	7	
1.11 Information for the User	7	
<b>2. Refrigerant information</b>		
<b>3. Description of the system</b>		
3.1 Main components	10	
3.2 Hydraulic module	14	
3.3 Technical data	18	
3.4 Accessories	19	
<b>4. Before installation</b>		
4.1 Reception	20	
4.2 Storage	20	
4.3 Handling	20	
4.4 Removing packaging	21	
4.5 Removing the transport bracket	22	
4.6 Dimensions and weights	22	
<b>5. Installation</b>		
5.1 General installation requirements	24	
5.2 Standard installation	25	
5.3 Installation in extreme weather conditions	26	
5.4 Ground assembly	28	
5.5 Wall assembly	29	
5.6 Handling	<b>30</b>	
5.7 Access to internal parts of the unit	32	
5.8 Condensate drain	35	
<b>6. Water connections</b>		
6.1 Preliminary check	36	
6.2 General system requirements (to be provided by the customer)	38	
6.3 Water pipes	38	
6.4 Water circuit frost protection	40	
6.5 Pipe insulation	43	
6.6 Water volume, system pressure and expansion tank control	44	
6.7 Filling / topping up with water	47	
<b>7. Electrical connections</b>		
7.1 Precautions for electrical connections	49	
7.2 General diagram	50	
7.3 Control box	52	
7.4 Location of connections	53	
7.5 Electrical connections	55	
7.6 Terminal block connection specifications	60	
7.7 SMART GRID - Photovoltaic management	63	
7.8 Dip-switch setting	64	
7.9 User interface	65	
7.10 Zone thermostat	70	
7.11 Units connected in cascade	71	
<b>8. Start-up - initial settings and functions</b>		
8.1 User interface	73	
8.2 Initial unit setting (requires a specialised Technician)	78	
<b>9. Control</b>		
9.1 Explanation of buttons	108	
9.2 Explanation of the display	109	
9.3 Explanation of the display	110	
9.4 Menu structure	111	
9.5 Home page	112	
9.6 Menu structure	113	
9.7 Unlocking the keypad	114	
9.8 Unit ON/OFF	115	
9.9 Controls OFF/ON	115	
9.10 Temperature control	118	
9.11 Select operation mode	120	
9.12 Default temperatures	121	
9.13 Climate temperature setting	122	
9.14 ECO mode	124	
9.15 Domestic hot water (DHW)	125	
9.16 Time schedule	129	
9.17 Options	134	
9.18 Service information	139	
9.19 Operation parameters	142	

**10. MODBUS registers**

10.1	Controls	143
10.2	States	145
10.3	States of units in cascade	148
10.4	Alarms	150
10.5	Password-protected unit parameters	152

**11. Serviceman warnings**

11.1	Controls in the area	156
11.2	Work procedures	156
11.3	General work area	156
11.4	Checking the presence of refrigerant	156
11.5	Presence of fire extinguishers	156
11.6	Absence of ignition sources	156
11.7	Area ventilation	157
11.8	Controls on refrigeration equipment	157
11.9	Controls on electrical devices	157
11.10	Repair of sealed components	157
11.11	Reparation of intrinsically safe components	158
11.12	Wiring	158
11.13	Detection of flammable refrigerants	158
11.14	Leak detection methods	158
11.15	Removal and evacuation	159
11.16	Charging operations	159
11.17	Disposal	159
11.18	Labelling	160
11.19	Recovery	160
11.20	Transport, marking and storage of units	160

**12. Maintenance****13. Troubleshooting**

13.1	General problems	163
13.2	Error codes	167

# 1. Safety considerations

## 1.1 Safety

Operate in compliance with the safety regulations in force.  
To perform the operations use the following protective equipment:

- gloves, goggles, hard hat, ear protection, protective footwear, protective knee pads.



All operations must be carried out by personnel trained on possible general, electrical and pressure equipment risks.

Only qualified personnel may operate on the unit, as required by the regulations in force.



### CAUTION DANGER

Before any intervention, read chapter “12. Maintenance” on page 161

## 1.2 Manual



The manual ensures proper installation, use and maintenance of the unit.

It is advisable to read this carefully so as to save time during the various operations. Follow the instructions given to prevent damage to persons or property.

## 1.3 Situations of Risk

The unit is designed and constructed so as not to expose people to health and safety risks.

In the project phase, it is not possible to outline all causes of risk.

Installation, start-up, maintenance and repair all require specific knowledge and, if such are carried out by inexperienced personnel, they may cause damage to property or people.

## 1.4 Intended use

The unit is intended only:

- for heating or cooling of water or water-glycol
- within the limits defined in the technical datasheet and in this manual

## 1.5 Installation



### CAUTION

Outdoor installation

The location, the water, refrigeration and electrical systems must be determined by the system designer according to local regulations in force.

Follow local safety regulations throughout all operations.

Verify that the power network characteristics are in compliance with data indicated on the serial number label of the unit.

## 1.6 Maintenance

---

Schedule periodic inspections and maintenance work in order to prevent or reduce repair costs. Disconnect voltage before any operation and wait 10 minutes before any action on electrical components.

## 1.7 Changes

---

All modifications to the unit will invalidate the warranty and void the manufacturer's liability.

## 1.8 Fault or malfunction

---

Disable the unit immediately if there is a fault or malfunction. Contact a service centre authorised by the manufacturer. Request the use of original spare parts. Using the unit when there is a fault or malfunction:

- voids the warranty
- may compromise the safety of the unit
- can increase repair costs and times

## 1.9 User training

---

The installer is to train the user on:

- Switch on/off
- Change setpoint
- Standby mode
- Maintenance
- What to do/not do in case of failure

## 1.10 Data updating

---

The continual improvements to the product may result in changes to the data shown in this manual. Visit the manufacturer's website for up-to-date data.

## 1.11 Information for the User

---

Keep this manual together with the wiring diagram in an accessible place for the operator. Make a note of the unit's identification data so that they can be provided to the service centre in the event of a service request (see paragraph ["1.1.2 Unit identification" on page 8](#)). Provide a logbook dedicated to the unit in which any interventions carried out on the unit can be noted and tracked, making it easier to suitably record the various operations and facilitate troubleshooting.

### 1.11.1 Ensure the installer is trained in:

---

- Switch on/off
- Change setpoint
- Standby mode
- Maintenance
- What to do/not do in case of failure

### 1.11.2 Unit identification

---

The serial number label is positioned on the unit to identify all the features of the unit. The serial number label bears the information required by the regulations, such as:

- the type of unit
- the serial number (12 characters)
- year of manufacture
- wiring diagram number
- electrical data
- type of refrigerant
- refrigerant charge
- manufacturer's logo and address

The serial number label is not to be removed for any reason.



**WARNING**

Tampering, removal, lack of identification labels or anything else that does not allow safe product identification, makes any installation and maintenance operation difficult.

### 1.11.3 Serial number

---

Uniquely identifies each unit.

Allows the specific spare parts for the unit to be identified.

### 1.11.4 Assistance request

---

Note down the characteristic data from the serial number label and record them in a table so that they are easily available when needed.

<b>Series</b>	CS2000 AWF / WLW 156
<b>Size</b>	
<b>Serial number</b>	
<b>Year of manufacture</b>	
<b>Wiring diagram number</b>	

## 2. Refrigerant information

**WARNING**

This product contains fluorinated greenhouse gases covered by the Kyoto protocol. It is essential to limit any leaks, otherwise it will be a major contributor to the anthropogenic greenhouse effect.

**WARNING**

Do not discharge gas into the atmosphere.

**Type of refrigerant: R-32**

The refrigerant quantity is indicated on the unit plate.

Quantity of refrigerant charged at the factory and tons of equivalent CO<sub>2</sub>:

Size	Volume of refrigerant charged at the factory	
	Refrigerant / kg	Tons of equivalent CO <sub>2</sub>
<b>2.1 (4kW)</b>	1.40	0.95
<b>3.1 (6kW)</b>	1.40	0.95
<b>4.1 (8kW)</b>	1.40	0.95
<b>5.1 (10kW)</b>	1.40	0.95
<b>6.1 (12kW)</b>	1.75	1.18
<b>7.1 (14kW)</b>	1.75	1.18
<b>8.1 (16kW)</b>	1.75	1.18
<b>9.1 (18kW)</b>	5.00	3.38
<b>10.1 (22kW)</b>	5.00	3.38
<b>12.1 (26 kW)</b>	5.00	3.38
<b>14.1 (30 kW)</b>	5.00	3.38

Physical characteristics of R-32 refrigerant		
Safety class (ISO 817)	A2L	
GWP (Global Warming Potential)	675	t CO <sub>2</sub> eq. 100yr
LFL Low flammability limit	14.4% v/v	Kg/m <sup>3</sup> @patm, 23 °C
BV Burning velocity	6.7	cm/s
Normal boiling point	-51.7	°C
Self-ignition temperature	648	°C

**FLAMMABLE MATERIAL**

The refrigerant used inside this unit is flammable. A refrigerant leak that is exposed to an external ignition source can create fire risks.

## 3. Description of the system

### 3.1 Main components

#### 3.1.1 Sizes 2.1 to 3.1

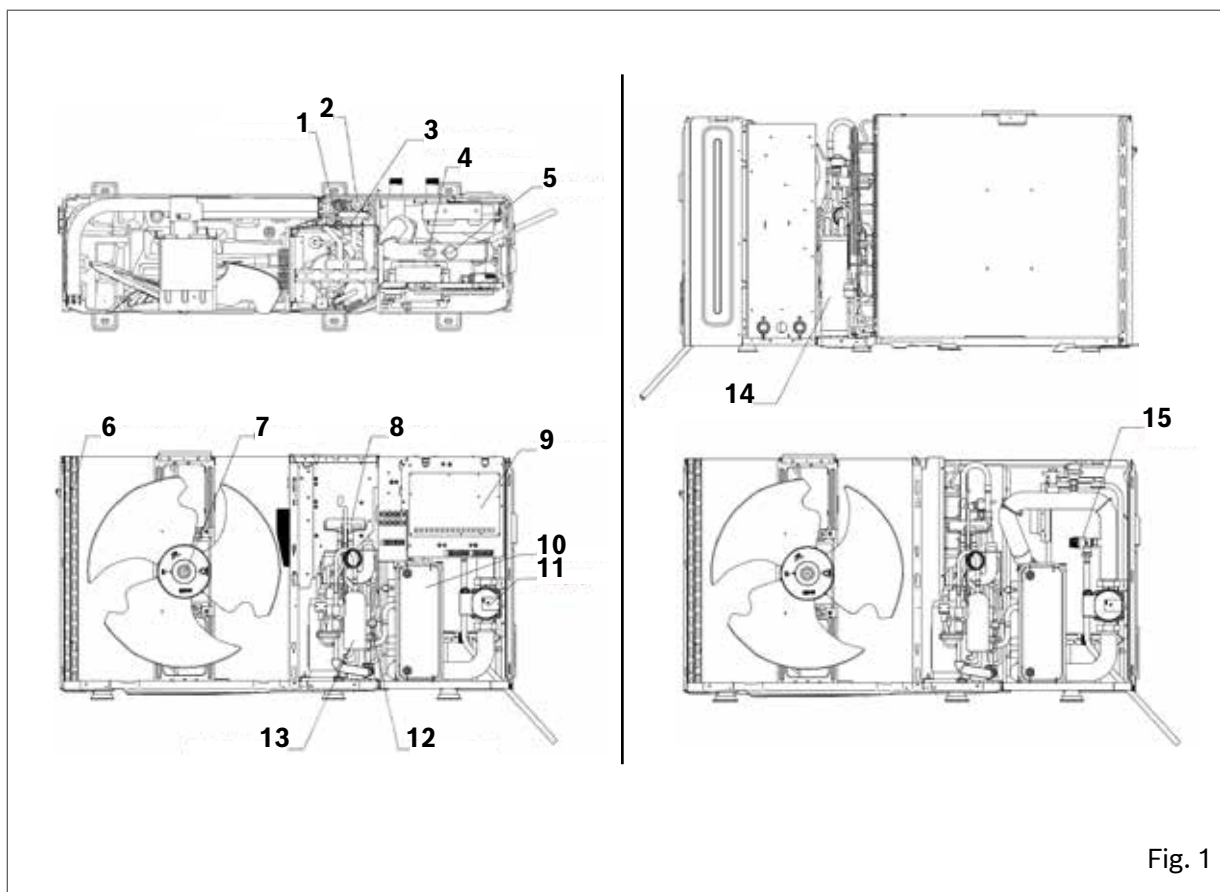

Fig. 1

No.	Component
1	Pressure sensor
2	Electronic expansion valve
3	HP pressure switch
4	Water flow switch
5	Air vent valve
6	Source exchanger: finned coil
7	Fan
8	4-way valve
9	Main board
10	Water side heat exchanger
11	Water circulator
12	LP pressure switch
13	Compressor inverter
14	Gas-liquid separator
15	Water pressure relief valve

## 3.1.2 Sizes 4.1 to 5.1

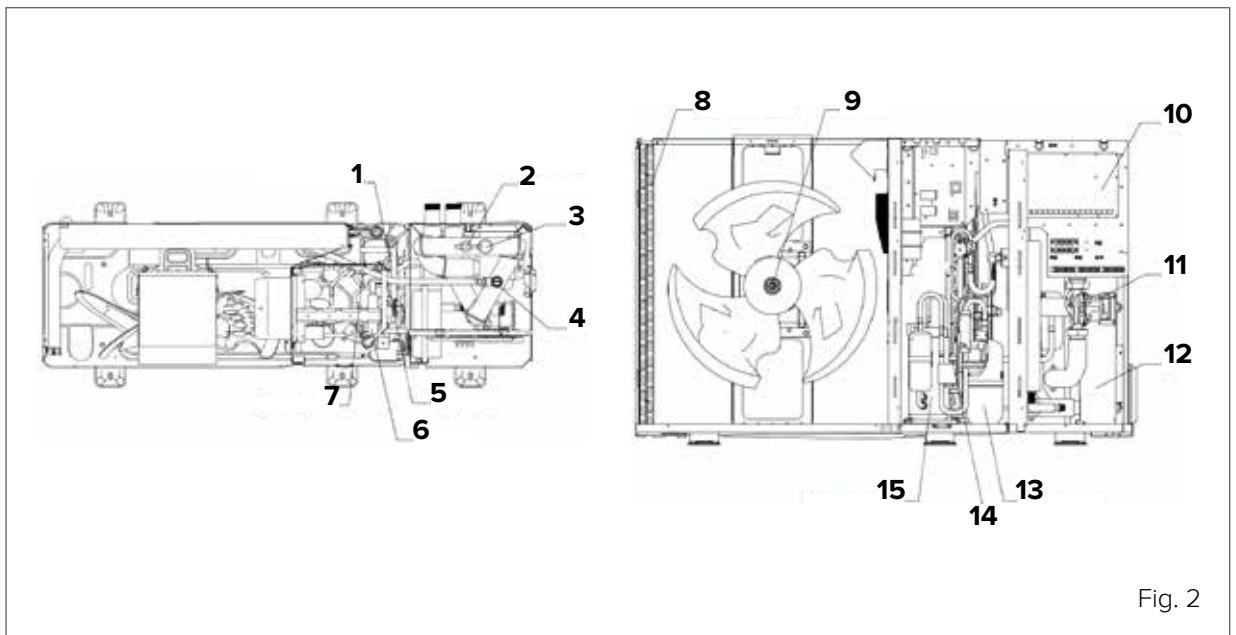

Fig. 2

No.	Component
1	Electronic expansion valve
2	Water flow switch
3	Air vent valve
4	Water pressure relief valve
5	Pressure sensor
6	4-way valve
7	HP pressure switch
8	Source exchanger: finned coil
9	Fan motor
10	Main board
11	Water circulator
12	Water side heat exchanger
13	Gas-liquid separator
14	LP pressure switch
15	Compressor inverter

## 3.1.3 Sizes 6.1 to 8.1

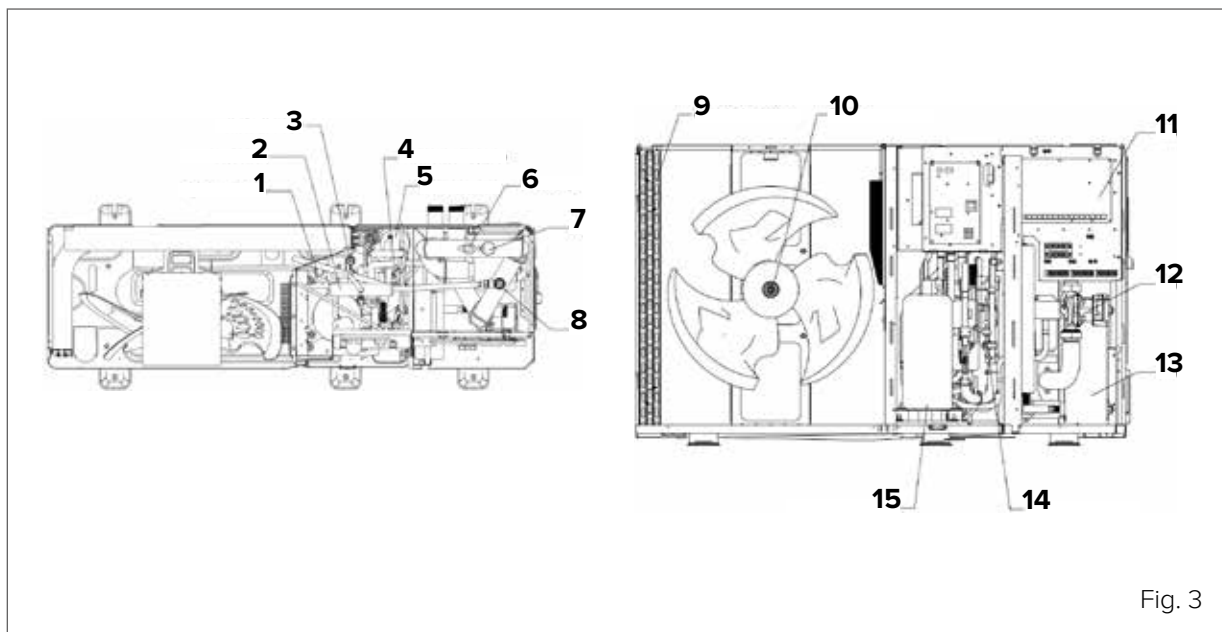

Fig. 3

No.	Component
1	HP pressure switch
2	4-way valve
3	Pressure sensor
4	Electronic expansion valve
5	Gas-liquid separator
6	Water flow switch
7	Air vent valve
8	Water pressure relief valve
9	Source exchanger: finned coil
10	Fan motor
11	Main board
12	Water circulator
13	Water side heat exchanger
14	LP pressure switch
15	Compressor inverter

## 3.1.4 Sizes 9.1 to 14.1

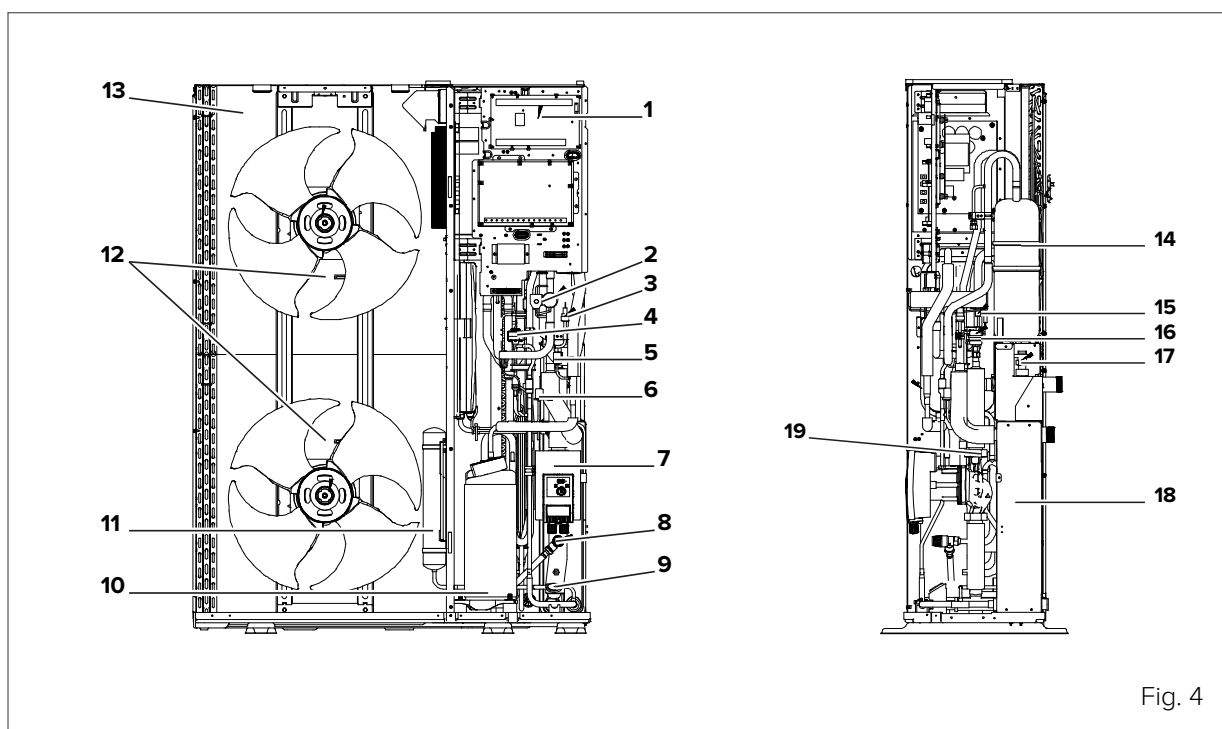

Fig. 4

No.	Component
1	Main board
2	4-way valve
3	Pressure sensor
4	Electronic expansion valve
5	HP pressure switch
6	LP pressure switch
7	Water circulator
8	Water pressure relief valve
9	Pressure gauge
10	Compressor inverter
11	Gas-liquid separator
12	Fan motor
13	Source exchanger: finned coil
14	Liquid receiver
15	Non-return valve
16	Air vent valve
17	Water flow switch
18	Water side heat exchanger
19	Expansion tank

**WARNING**

The pictures in this manual are provided for illustrative purposes only. The appearance of your appliance may differ slightly from the illustrations shown here. Refer to the actual characteristics of the unit.

## 3.2 Hydraulic module

### 3.2.1 Sizes 2.1 to 3.1

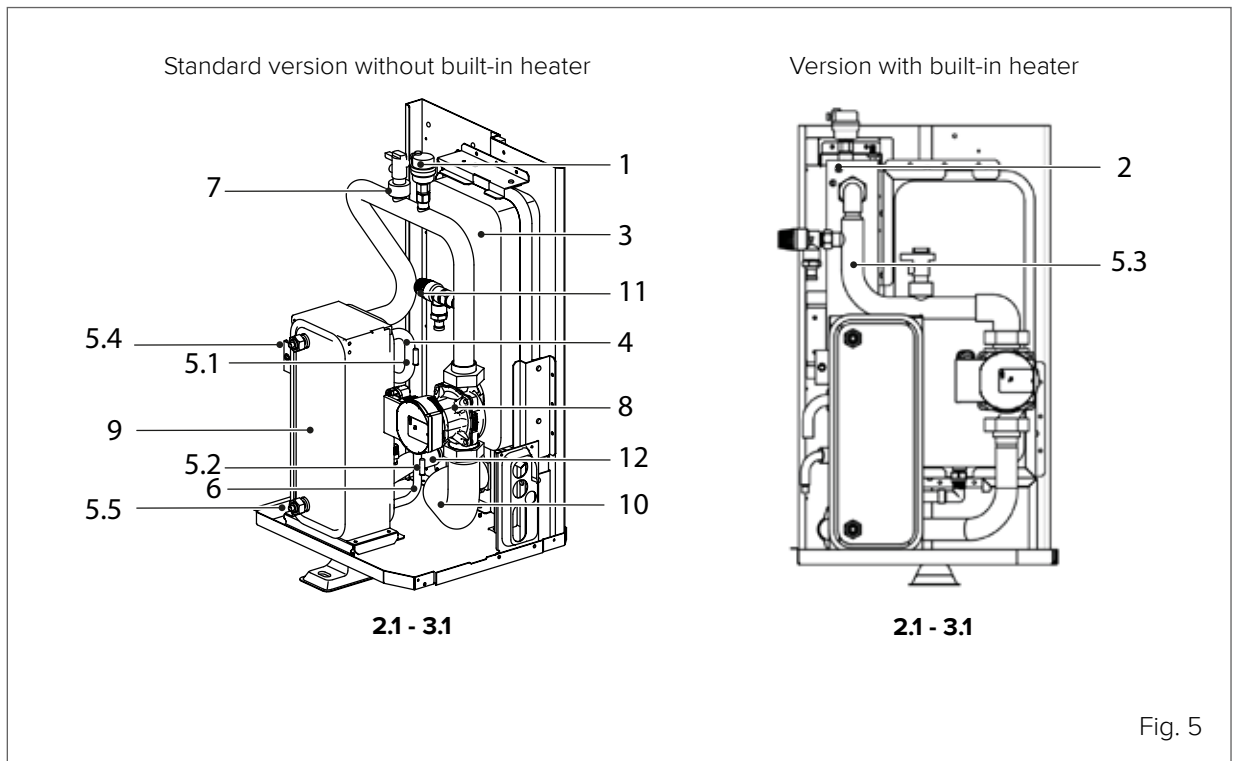
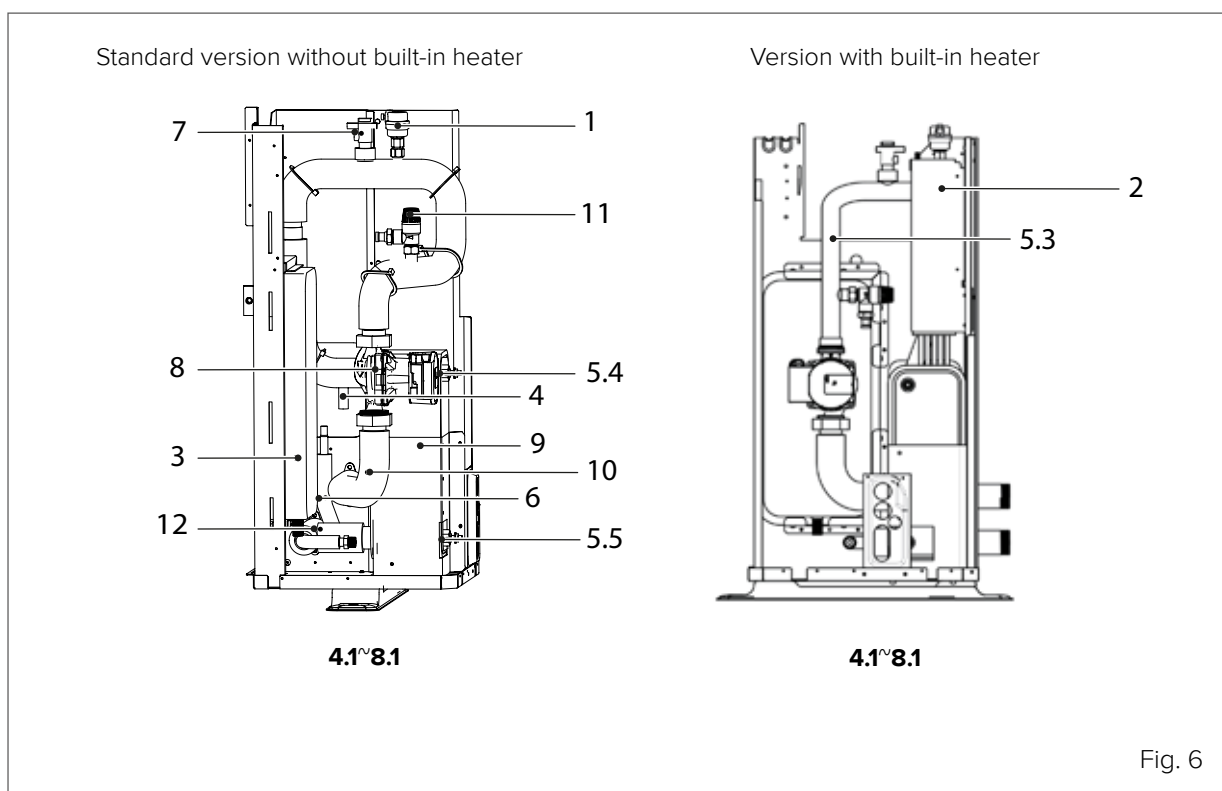

Fig. 5

No.	Component
1	Automatic air vent
2	Additional/backup (optional configuration)
3	Expansion tank
4	Refrigerant gas
5	Temperature sensors
6	Refrigerant pipe
7	Flow switch
8	Pump
9	Plate heat exchanger
10	Water outlet pipe
11	Pressure relief valve
12	Water inlet pipe

## 3.2.2 Sizes 4.1 to 8.1



No.	Component
1	Automatic air vent valve
2	Additional/backup electric heater (optional configuration)
3	Expansion tank
4	Refrigerant gas pipe
5	Temperature sensors
6	Refrigerant pipe
7	Flow switch
8	Pump
9	Plate heat exchanger
10	Water outlet pipe
11	Pressure relief valve
12	Water inlet pipe



3.2.3 Sizes 9.1 to 14.1

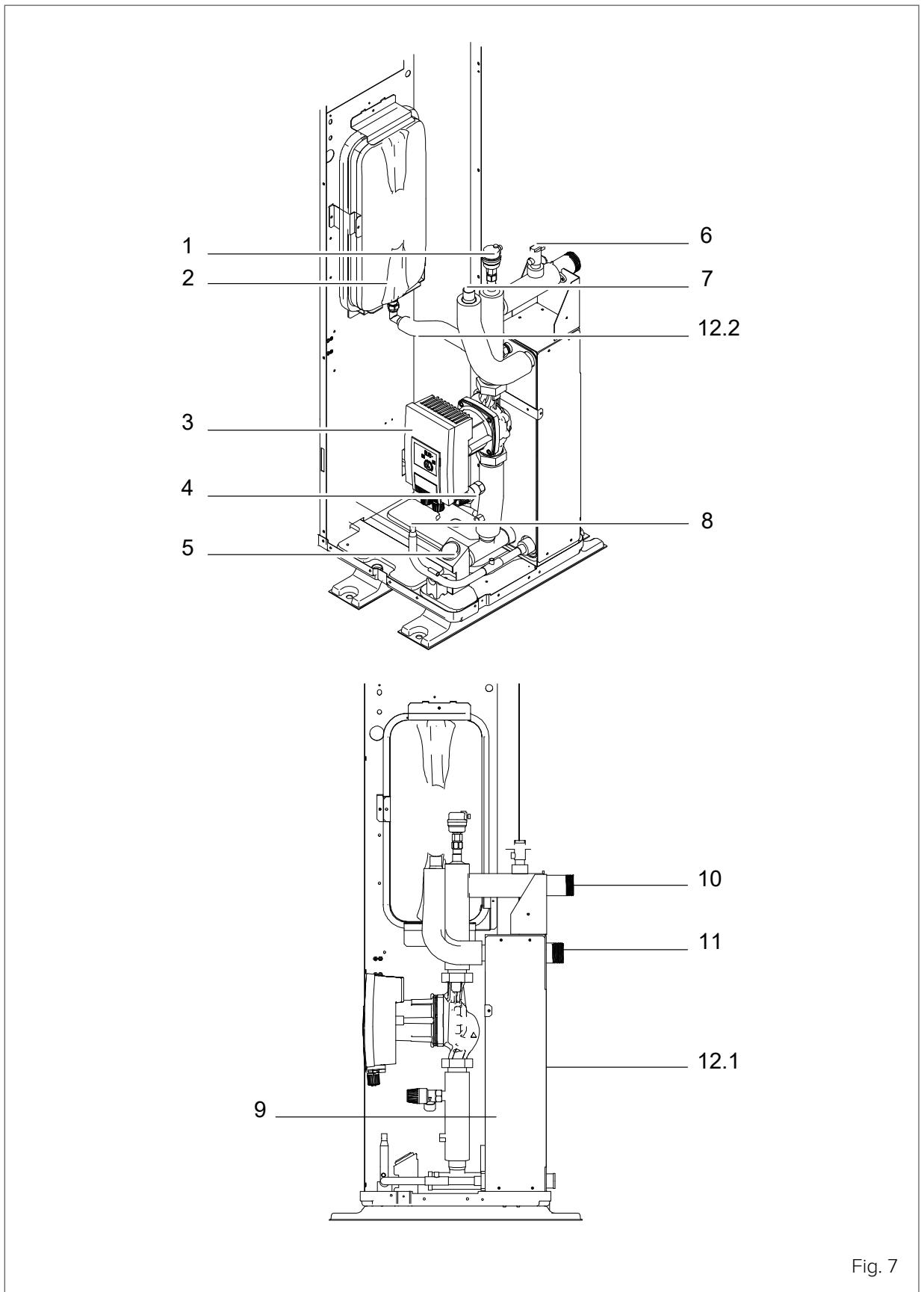

Fig. 7



No.	Component
1	Automatic air vent valve
2	Expansion tank
3	Circulation pump
4	Pressure relief valve
5	Pressure gauge
6	Flow switch
7	Refrigerant gas pipe
8	Refrigerant pipe
9	Plate heat exchanger
10	Water outlet pipe
11	Water inlet pipe
12.1	Electric heating tape
12.2	Electric heating tape
13	Temperature sensors

### 3.3 Technical data

For optimum performance use the unit in the following ambient temperature ranges.

Models 2.1 ~8.1 cooling mode	-5°C to 43°C
Models 9.1 ~14.1 cooling mode	-5°C to 46°C
Heating mode	-25°C to 35°C
DHW production	-25°C to 43°C

Keep the measurement guidelines in mind:

Maximum height difference between the domestic hot water tank and the unit	3m
Maximum permissible distance between the unit and...	
Domestic hot water tank	10m
3-way valve	10m
Additional/backup electric heater - boiler	10m



#### CAUTION

In the case of larger distances, contact the supplier for information on possible risks and suggestions to limit them.



#### CAUTION

If the unit is far away from the DHW storage tank, measure the connection pipes accordingly and check that they are properly insulated.

#### 3.3.1 Maximum temperatures of components not supplied by Bosch

System	75°C
DHW	95°C

## 3.4 Accessories

---

### 3.4.1 Accessories supplied with the unit

---

The following accessories are included in the “A” or “B” packaging:

Description	Quantity
Installation, use and maintenance manual	1
Energy label	1
Y filter	1
User interface	1
Water temperature probe (for T5 / T1 / Tw2 / Tbt1 / Tsolar)	1
Condensate drain fitting	1
Cable tie	3
Termination heater for connecting M/S units in cascade	1

## 4. Before installation

### 4.1 Reception

---

Before accepting the delivery, check:

- that the unit has not been damaged during transport;
- that the materials delivered correspond with that indicated on the transport document, comparing the data with the identification label positioned on the packaging.

In case of damage or anomaly:

- immediately take note of the damage discovered on the transport document and write: “Accepted with reservation due to evident shortages/damages during transport”;
- contest by fax and registered mail with proof of receipt to the supplier and carrier.

---

**NOTE**

Any disputes must be raised within 8 days from delivery. Complaints after this period are invalid.

---

### 4.2 Storage

---

Observe external packaging instructions. In particular:

- minimum room temperature  $-10^{\circ}\text{C}$  (possible damage to components);
- maximum room temperature  $+50^{\circ}\text{C}$  (possible pressure relief valve opening);
- maximum relative humidity 95% (possible damage to electrical components).

---

**NOTE**

The unit may not be tilted more than  $15^{\circ}$  during transport.

---

### 4.3 Handling

---



**CAUTION**

- Check that all handling equipment complies with the local safety regulations (cranes, forklift trucks, ropes, hooks, etc.).
  - Provide personnel with personal protective equipment appropriate for the situation, such as hard hat, gloves, safety shoes, etc.
  - Follow all safety procedures to ensure the safety of personnel and materials.
  - To avoid injury, do not touch the unit's air inlet or aluminium fins.
  - Do not use the fan grille handles to move the unit.
  - Handle the unit with equipment appropriate to its weight (see paragraph “4.6 Dimensions and weights” on page 22).
  - Keep the unit packed during handling. Do not remove the packaging until these operations are completed.
-



### HANDLING WITH A CRANE

Pass the straps for slinging the unit through the holes provided on the wooden packing pallet.  
Lift carefully and avoid sudden movements.  
Position the unit close to the installation site.

### HANDLING WITH A FORKLIFT TRUCK

The unit can also be moved with a forklift truck using the holes provided on the base of the wooden pallet.

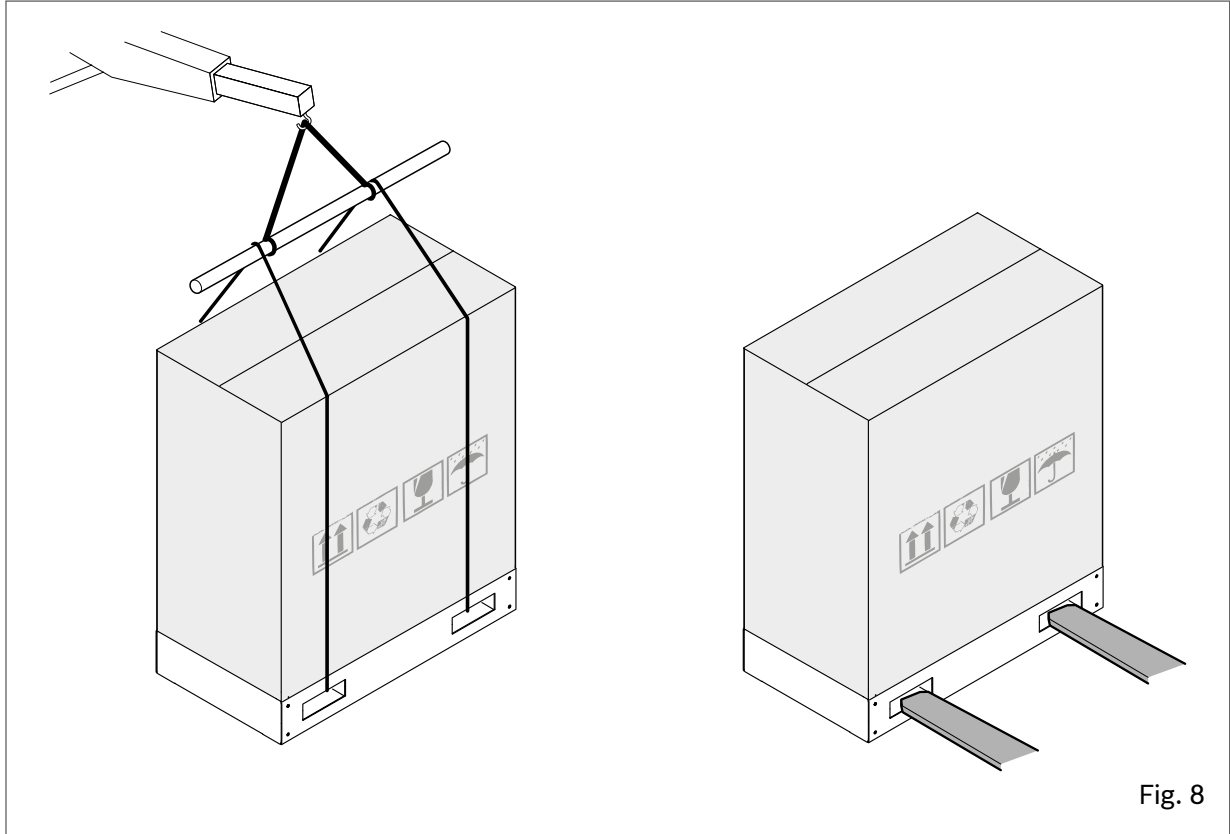

## 4.4 Removing packaging

Once you have reached the installation site, remove the wooden pallet by unscrewing the screws at the base of the unit, the packaging cardboard and the coil protection (1).

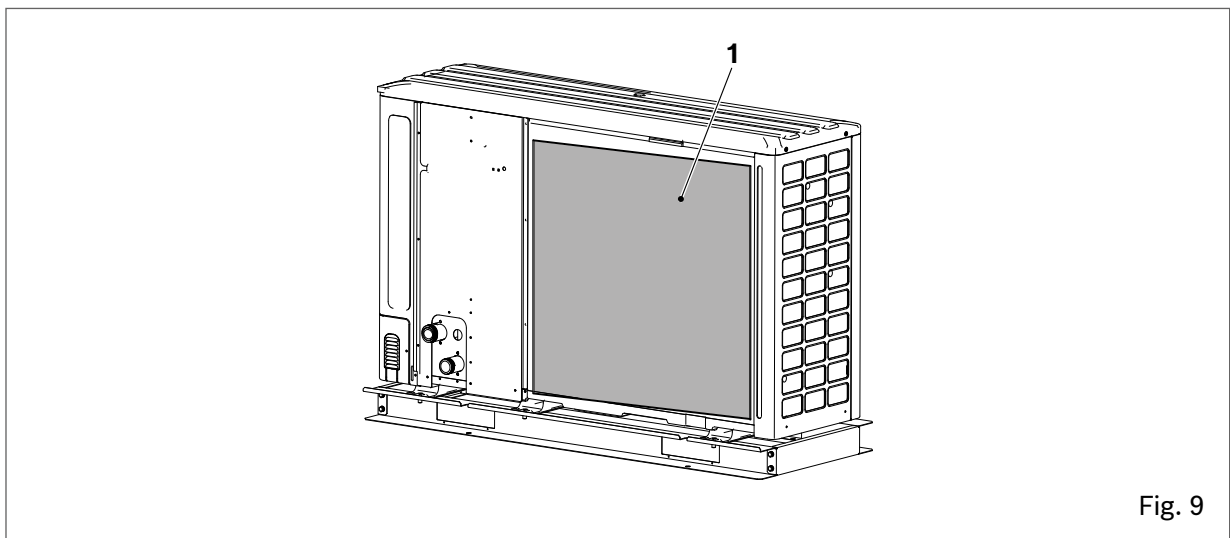

## 4.5 Removing the transport bracket

For models **6.1**, **7.1** and **8.1**, remove the bracket **(3)** used during transport to avoid stressing the compressor.

- Remove the front panel **(1)**.
- Remove the screws **(2)**.
- Remove the bracket **(3)**.

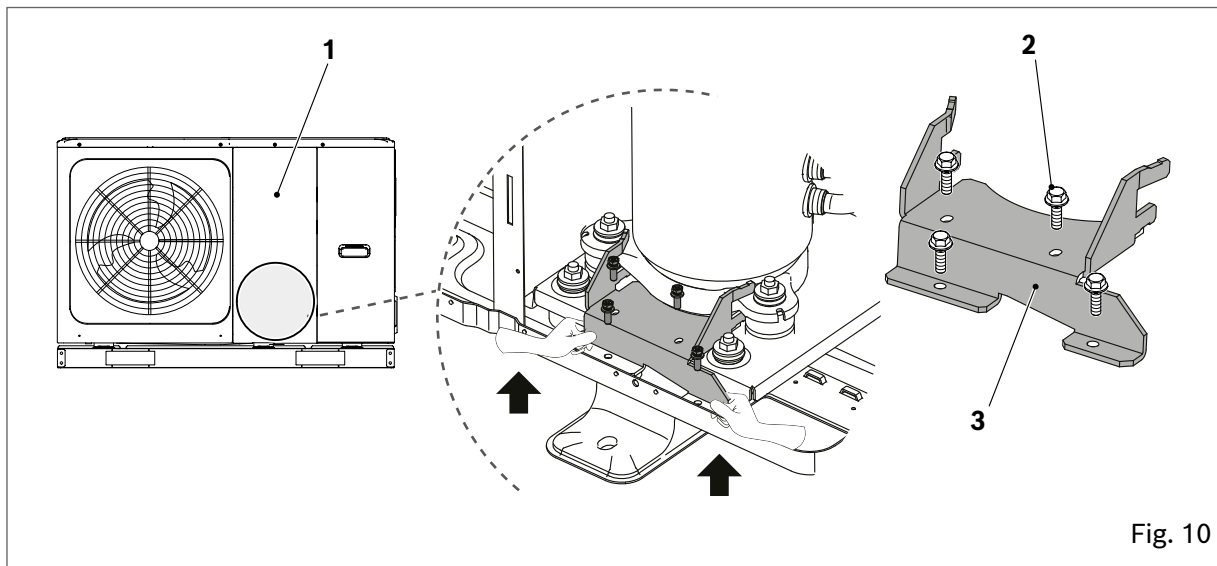

Fig. 10

## 4.6 Dimensions and weights

### 4.6.1 Sizes 2.1 to 3.1

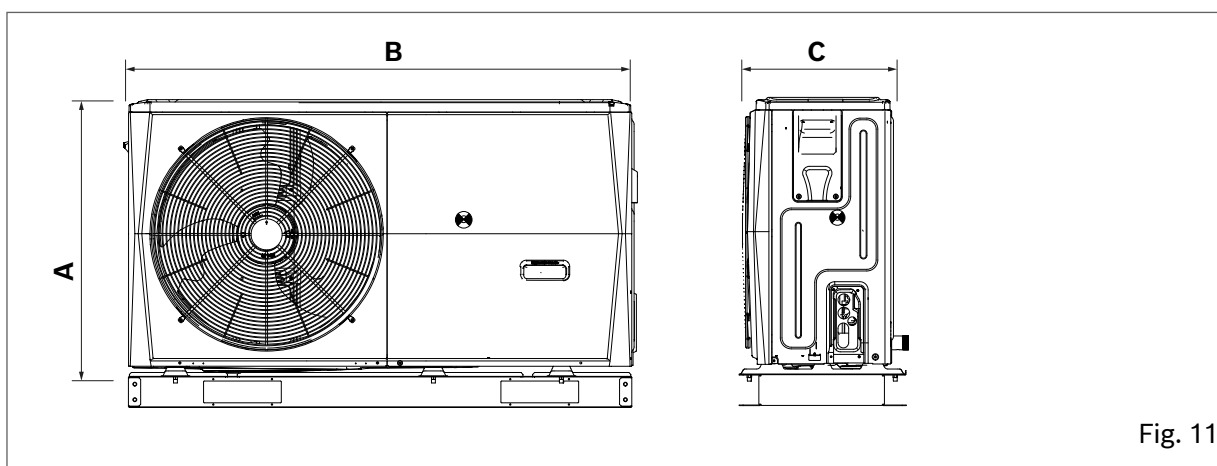

Fig. 11

		Size	
		2.1	3.1
Height (A)	mm	717	717
Width (B)	mm	1295	1295
Depth (C)	mm	400	400
Weight	kg	86	86

## 4.6.2 Sizes 4.1 to 8.1

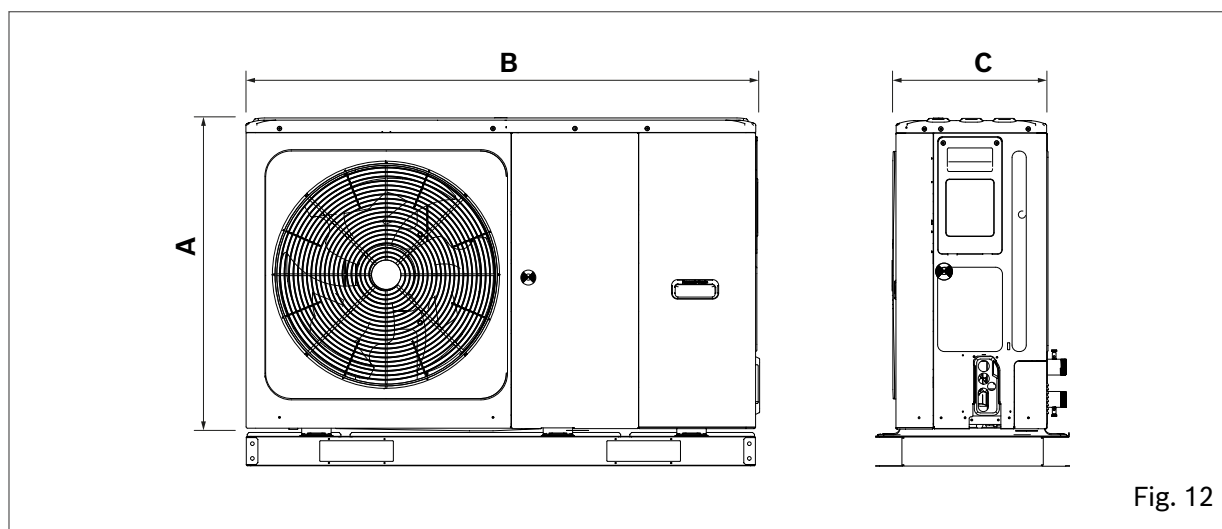

Fig. 12

		Size				
		4.1	5.1	6.1	7.1	8.1
Height (A)	mm	864	864	864	864	864
Width (B)	mm	1385	1385	1385	1385	1385
Depth (C)	mm	445	445	445	445	445
Weight	kg	105	105	129	129	129

## 4.6.3 Sizes 9.1 to 14.1

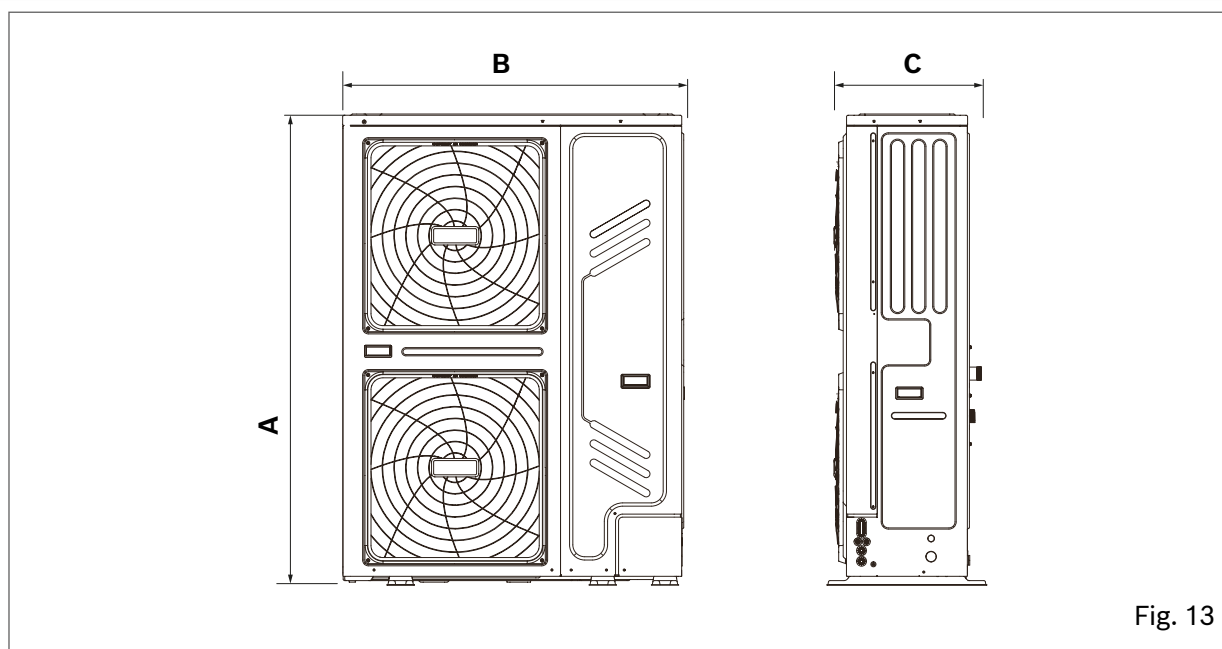

Fig. 13

		Size			
		9.1	10.1	12.1	14.1
Height (A)	mm	1557	1557	1557	1557
Width (B)	mm	1120	1120	1120	1120
Depth (C)	mm	400	400	400	400
Weight	kg	177	177	177	177

## 5. Installation

### 5.1 General installation requirements

---

The installation site must fulfil the following conditions:

- Well-ventilated areas ensuring an exchange of treated air.
- Areas where the unit will not disturb neighbours.
- Safe areas that can withstand the weight and vibrations of the unit and where it can be installed on flat ground. The unit is designed for outdoor installation.
- Areas that are not exposed to flammable gas or product leaks.
- Areas free from potentially explosive atmospheres.
- Areas with adequate functional spaces including operating spaces and spaces required for extraordinary and routine maintenance.
- Areas that allow the maximum specified lengths for the unit's piping and electric cables to be adhered to.
- Areas where any water leaks from the unit cannot cause damage (e.g. if the drain pipe is blocked).
- Areas protected from prolonged exposure to sunlight or rain.
- Areas with adequate functional spaces including operating spaces and spaces required for extraordinary and routine maintenance.
- Areas protected from heat sources.
- Clean and protected areas so that the unit cannot be used as a refuge for small animals. Contact between these animals and electrical components can cause malfunctions or fires.
- Compliance with EN 378, in case of indoor installation in large rooms, as the unit contains flammable refrigerant. The unit is designed for outdoor installation.

Be careful:

- Not to install the unit in areas that are frequently used as workspaces. In the event of construction work that produces large amounts of dust (e.g. grinding, etc.), the unit must be covered.
- Not to place any objects or equipment on the unit (on the top panel).
- Not to sit or stand on the unit.
- Not to install the unit in places with high salinity or in the presence of corrosive gases.
- Not to install the unit in places where it will be subjected to continuous vibration.
- To provide a water drain duct around the base to ensure the drainage of discharge water around the unit. If it is difficult to drain the water from the unit, place the unit on a raised base.



---

#### CAUTION

In the event of refrigerant leaks, take sufficient precautions in accordance with applicable laws and regulations.

---

## 5.2 Standard installation

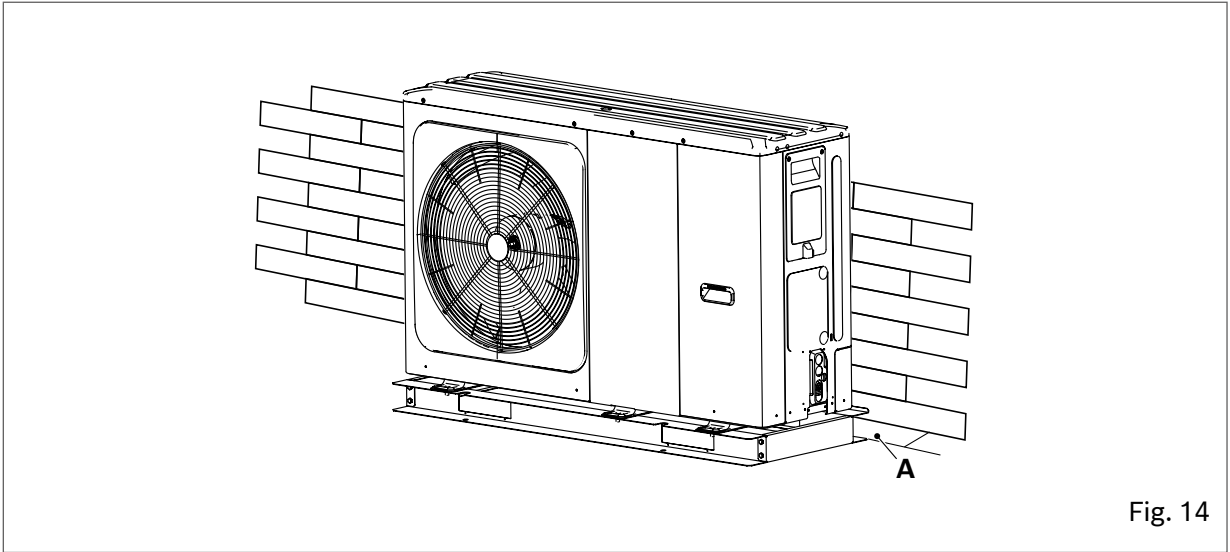

Fig. 14

Size	A(mm)
2.1~14.1	≥300

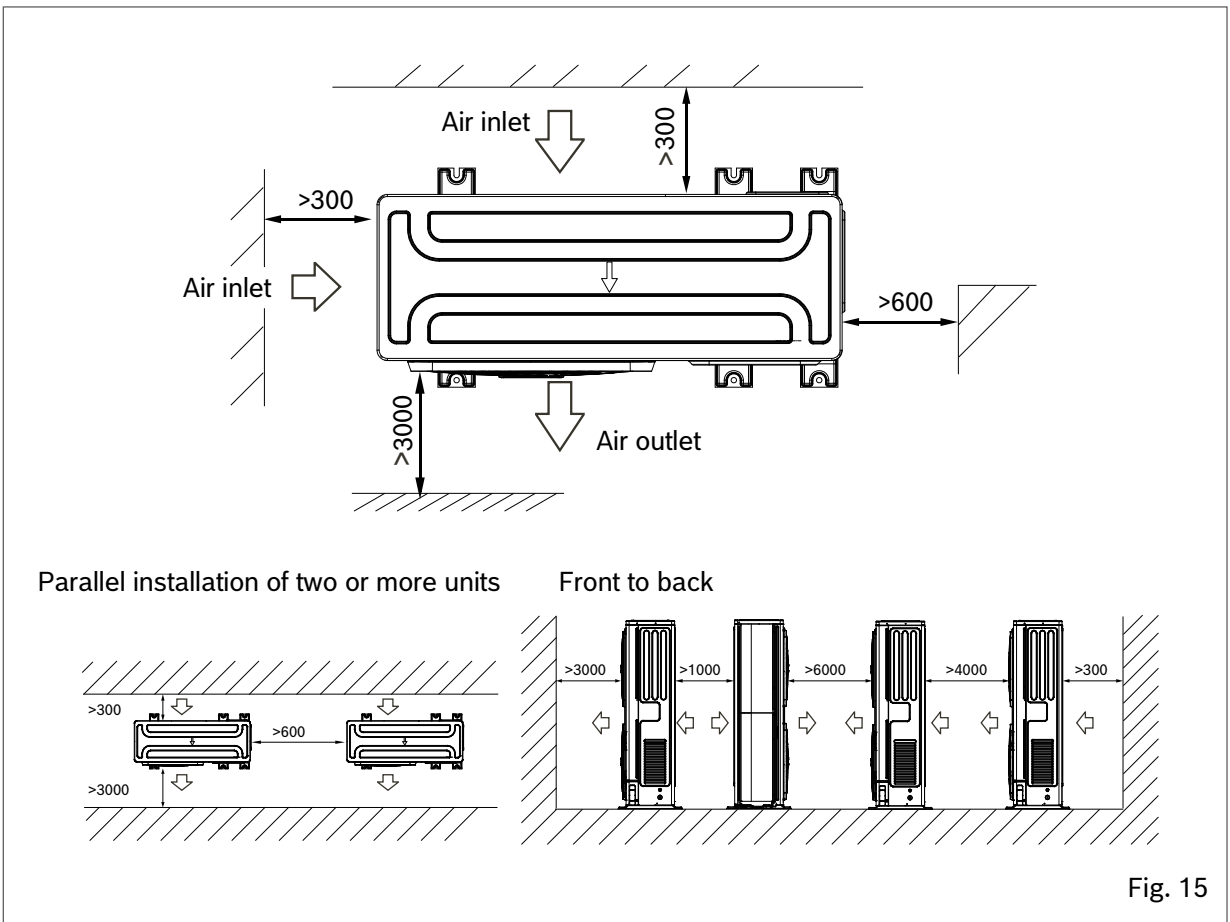

Fig. 15

## 5.3 Installation in extreme weather conditions

### 5.3.1 Unit exposed to strong wind

- Do not install the unit in a location where the suction side may be directly exposed to wind.
- Install the unit so that the air outlet fan is 90° to the direction of the wind.
- If necessary, place a barrier (A) in front of the unit to protect it from particularly strong winds.
- Set the outlet side at right angles to the wind direction.

A wind speed of 5 m/sec. or more blowing against the unit's air outlet will cause a short circuit (exhaust air intake), the consequences of which may be as follows:

- Decrease in operational capacity.
- Frequent acceleration of ice formation.
- Interruption of operation due to high or low pressure alarm.

When a strong and continuous wind blows against the front of the unit, the fan may start to rotate very fast until it breaks.

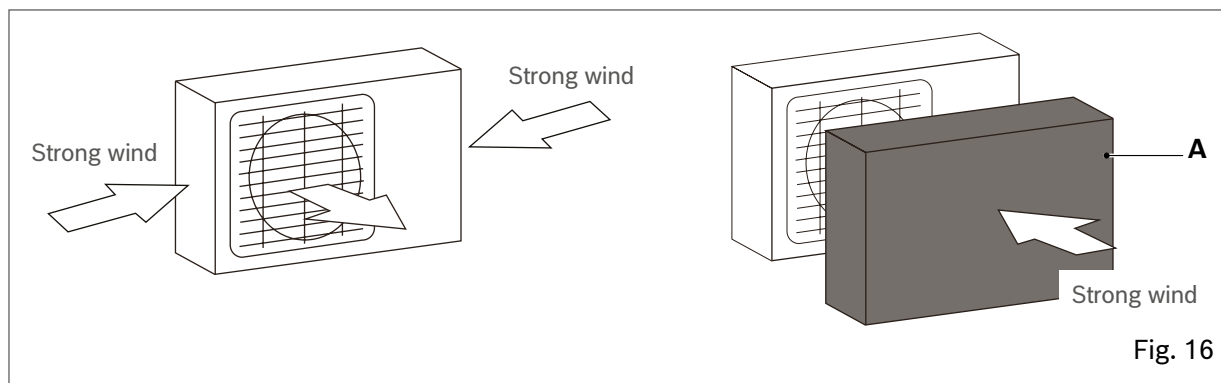

If the wind direction can be predicted, refer to the figures below for installation of the unit. Turn the air outlet side towards the wall, boundary element or building shield.

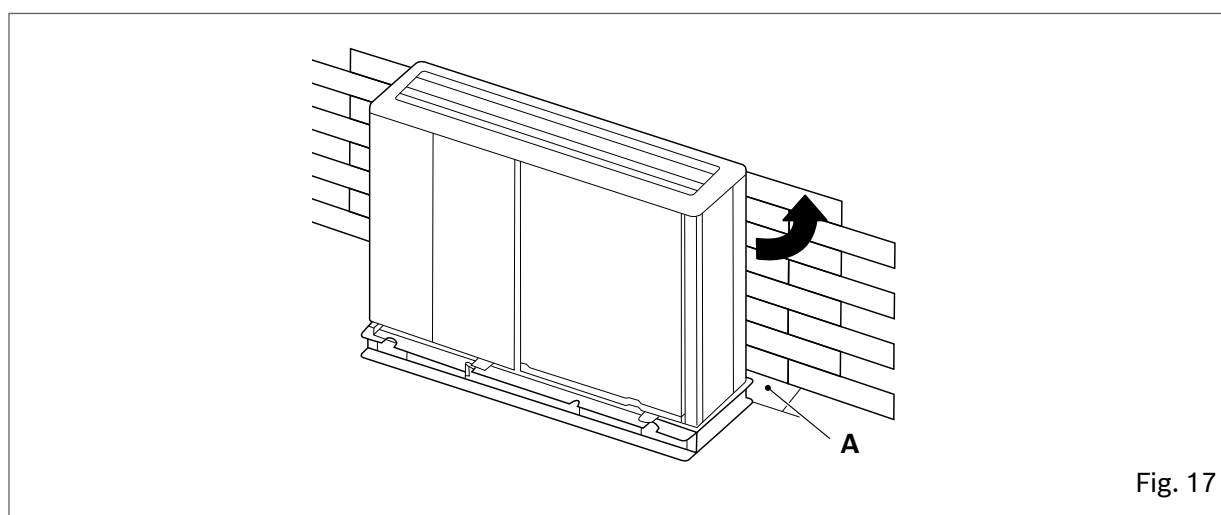

Size	A(mm)
2.1~3.1	≥1000
4.1~8.1	≥1500
9.1~14.1	≥1500

### 5.3.2 Unit exposed to direct sunlight

Since the outdoor temperature is measured by the unit's thermistor, it is recommended to install the unit in a shady location or under a canopy to protect it from direct sunlight and heat.

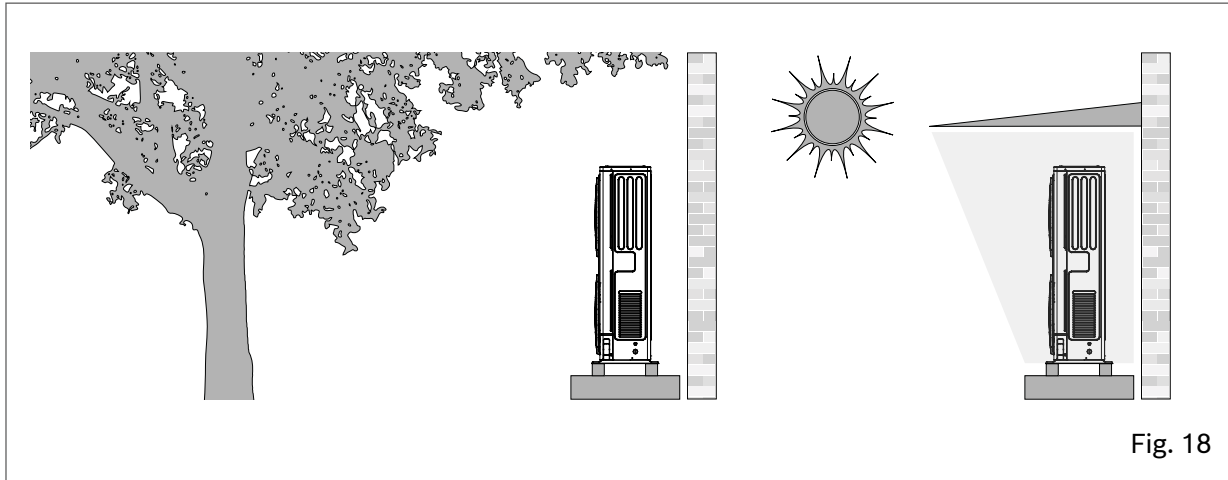

Fig. 18

### 5.3.3 Unit exposed to heavy rain or snow

- Install a canopy above the unit to protect it from rain or snow. Make sure the heat exchanger is not exposed to snow (if necessary, build a side canopy).
- Make sure the airflow around the unit is not obstructed.
- Provide a raised base on which to install the unit.

The base must be high enough to prevent the unit from being covered with snow. It is advisable to leave at least 100mm above the maximum height in the event of heavy snowfall.

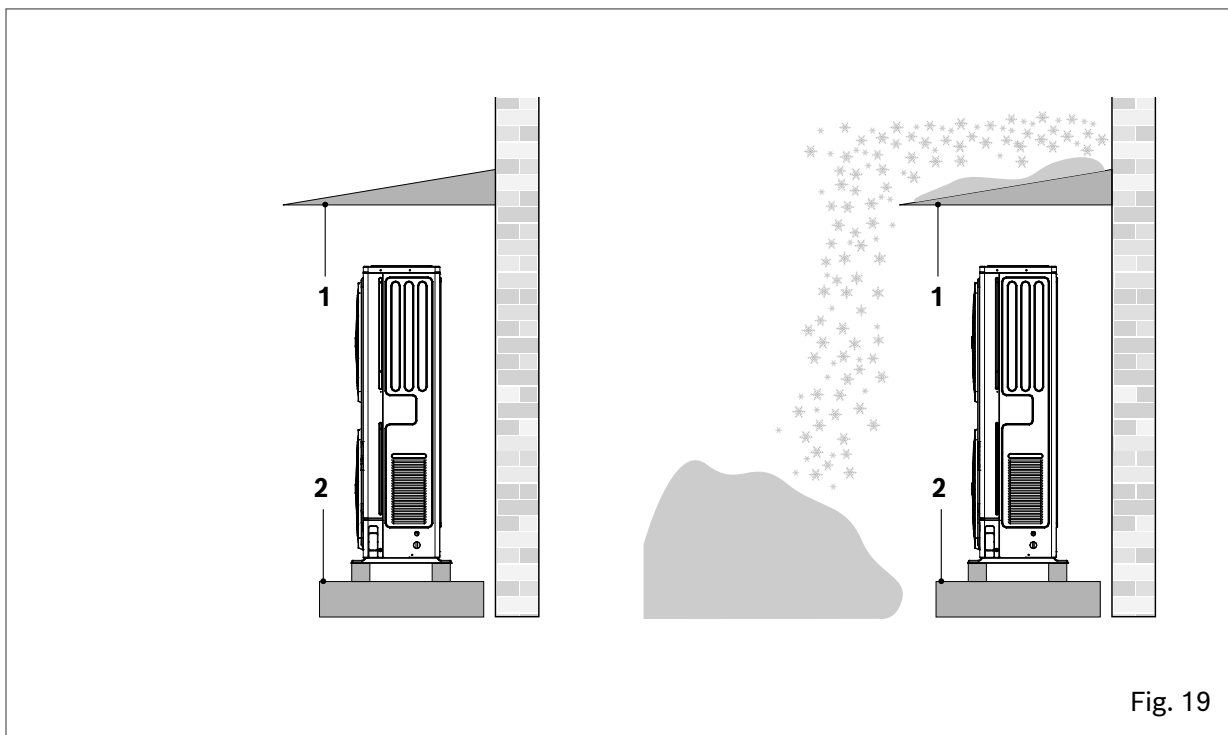

Fig. 19

- 1 Build a canopy.
- 2 Build a raised base.

## 5.4 Ground assembly

Use 6 sets of M12 anchor bolts, nuts and washers to secure the unit to the base.

Leave a space of at least 150 mm under the unit.

Place the unit on suitable antivibration mounts sized according to the weight of the unit so as to effectively dampen vibrations. Use antivibration mounts provided by the supplier or equivalent.

Rubber antivibration mounts, anti-seismic and for installation with inertial storage, with condensate drain tray or with brackets for wall installation, are available.

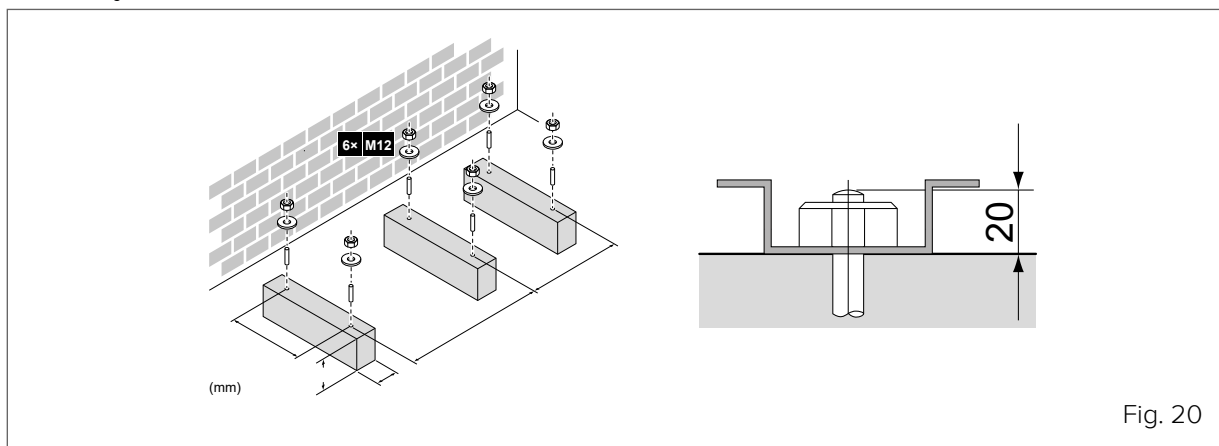

Fig. 20

### 5.4.1 Dimensions for ground fixing

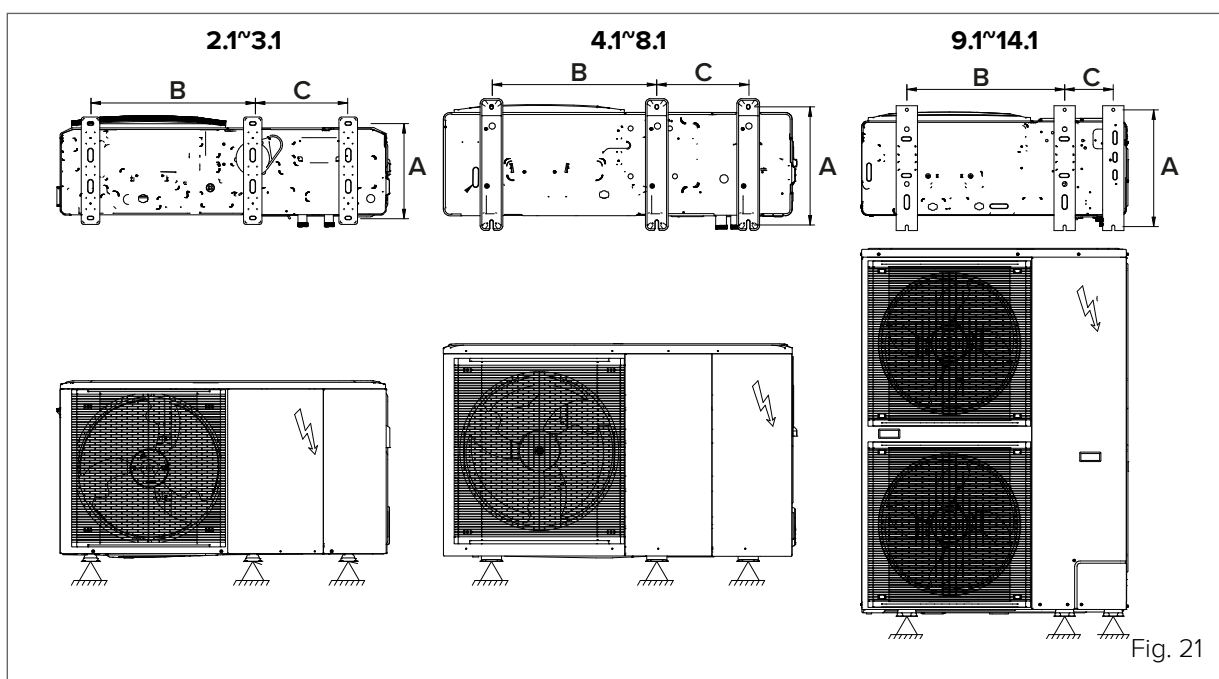

Fig. 21

		Size										
		2.1	3.1	4.1	5.1	6.1	7.1	8.1	9.1	10.1	12.1	14.1
A	mm	375				469				494		
B	mm	644				656				688		
C	mm	379				363				206		

The recommended height of the top protruding part of the bolts is 20 mm.

**CAUTION**

It is important to secure the unit with foundation bolts in accordance with the foundation drawing in "Fig. 22".

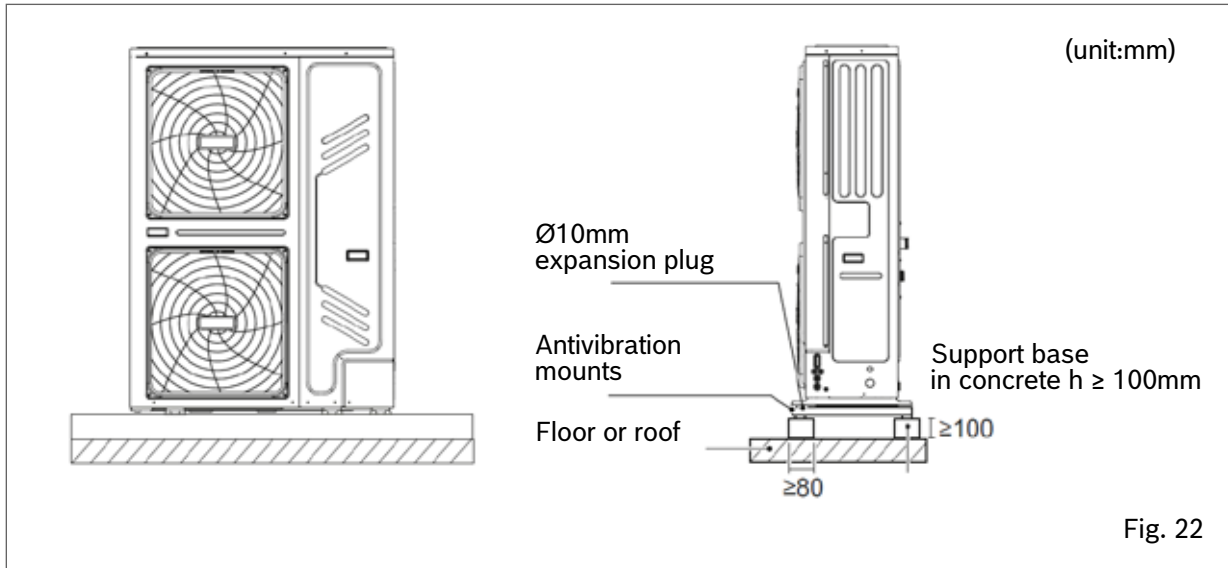

Fig. 22

## 5.5 Wall assembly

Two kits are available to secure the unit to the wall: bracket kit; fixings in detail A are included, wall fixings are provided by the customer antivibration mount kit.

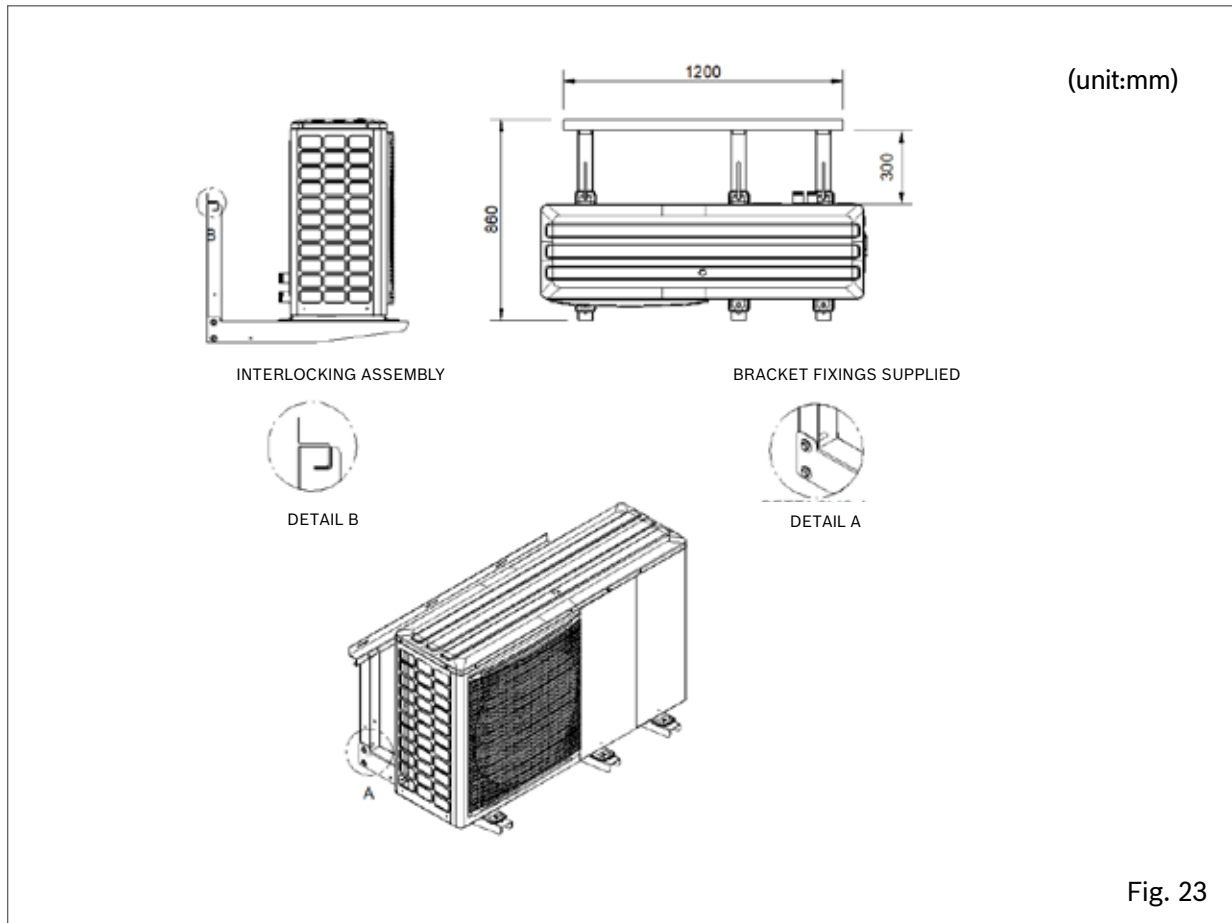

Fig. 23

## 5.6 Handling

Place the unit on the installation structure using slings.



### CAUTION

Do not tilt or damage the unit during handling.

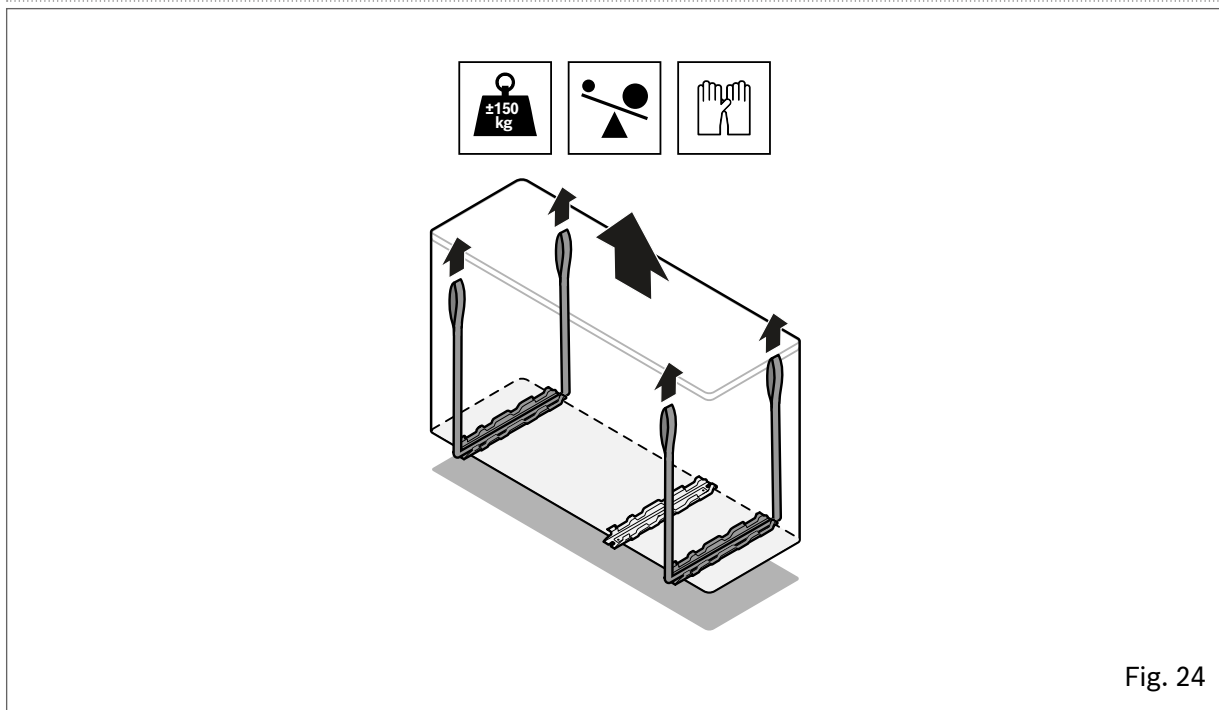

- Assemble the unit on the installation structure.

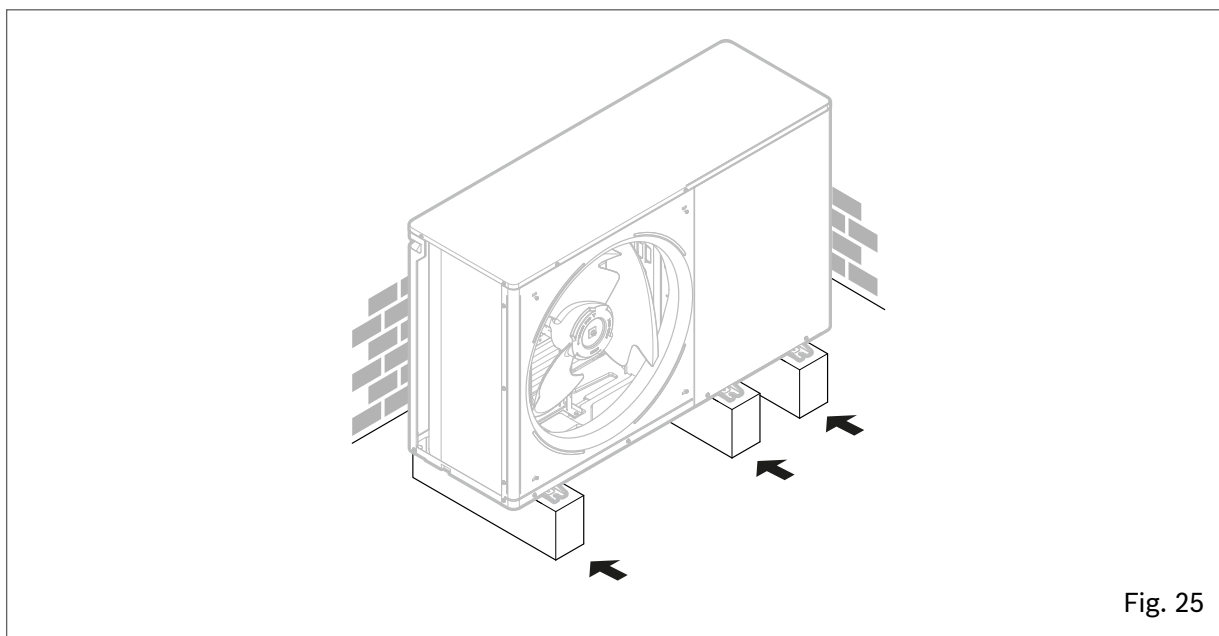

### WARNING

If the unit's drainage holes are covered by the installation base or floor surface, raise the unit to leave a gap of at least 120mm under the unit.



Connect the condensate drain and duct it in accordance with current regulations. Avoid siphons and short radius bends that can cause obstructions. Be careful to avoid possible accidental obstructions during operation.

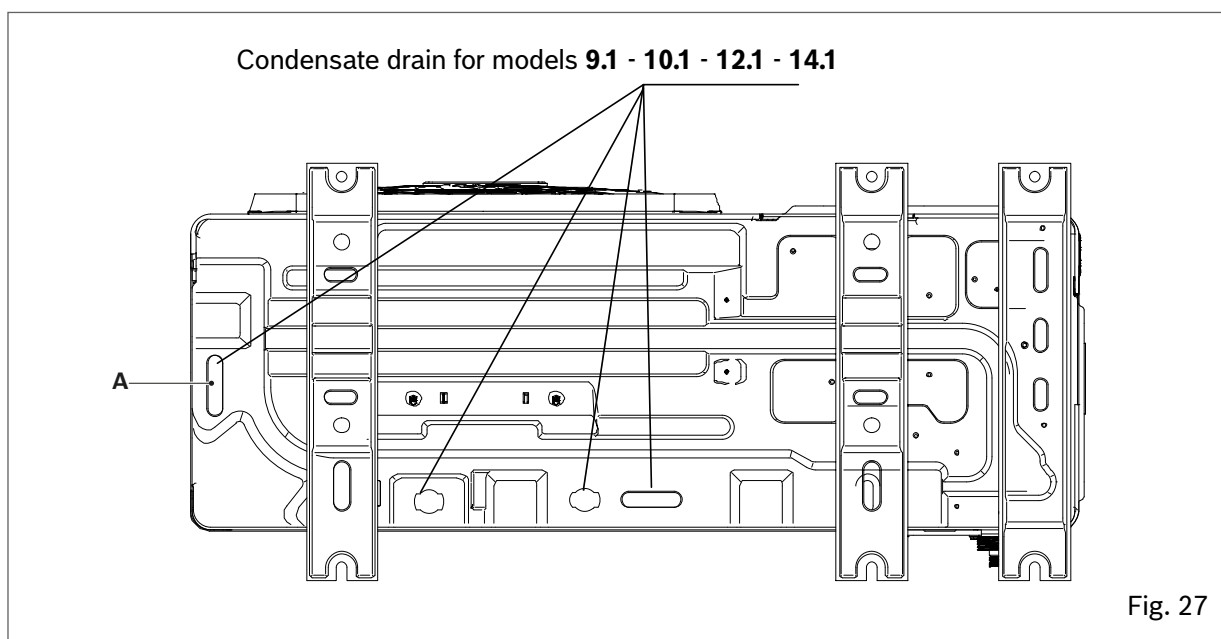
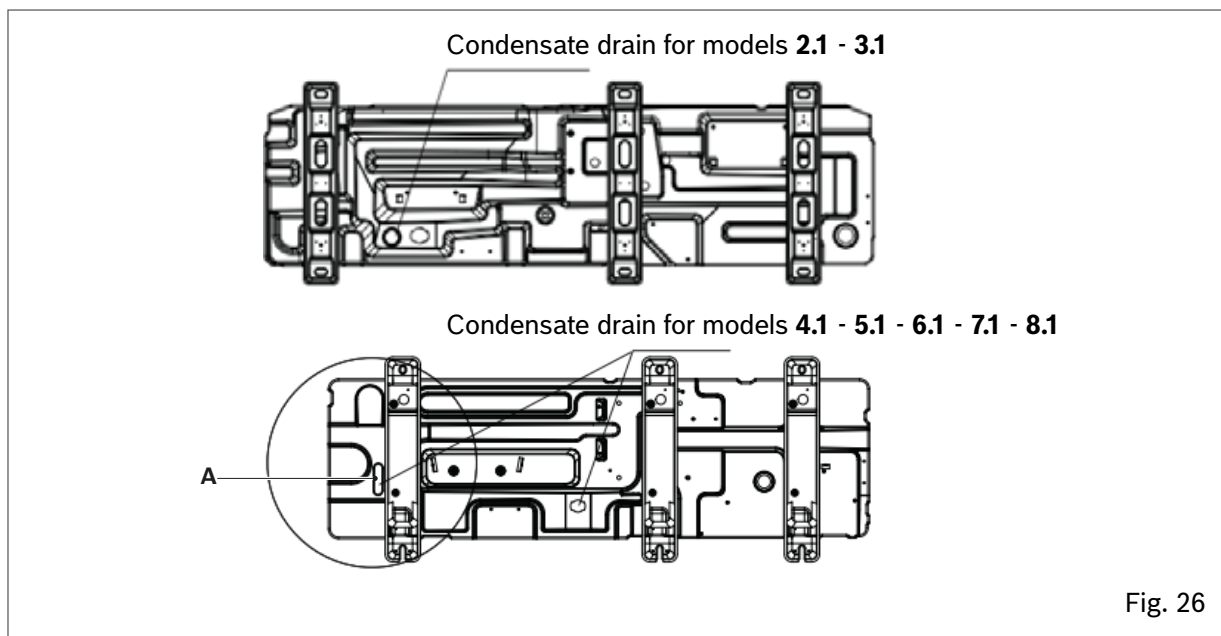

The drain hole (A) is covered by a rubber plug. If the smaller drain hole cannot fulfil the drainage requirements, the larger drain hole can be used at the same time.

## 5.7 Access to internal parts of the unit

The appliance has removable protection panels. To remove the protections:

- unscrew the 4 screws in the panel;
- pull the panel off.

Reassemble following the removal procedure in reverse order.

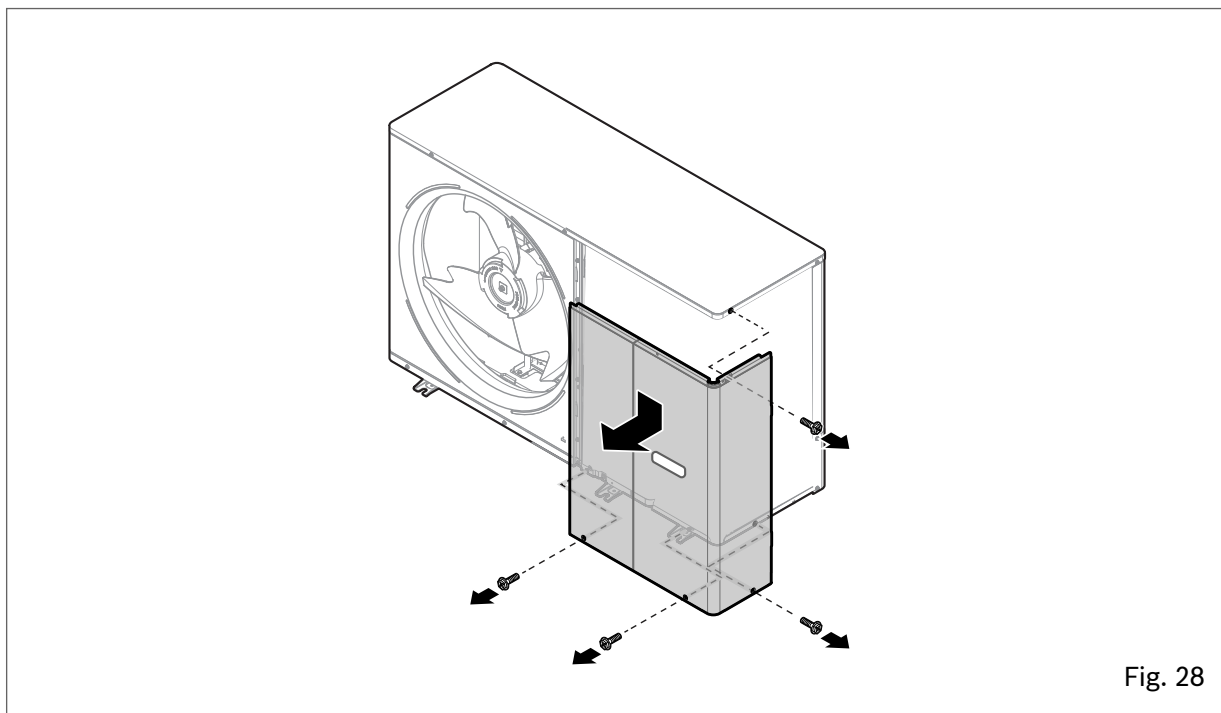

### CAUTION

Risk of electric shock, burns and scalding.

## 5.7.1 DHW tank

As an option, the unit can be connected to a DHW storage tank of suitable volume, by fitting the system with a 3-way diverter valve controlled by the unit. To optimise the efficiency of the system, it is advisable to install the 3-way valve and the DHW storage tank as close as possible to the unit. Use fast-switching valves with low pressure drop and reduced leakage. Refer to the DHW storage tank manual for installation details.

Measure the connection pipes properly and thermally insulate them, especially if the unit is far away from the DHW storage tank.

Nevertheless, it is advisable to connect the storage tank at no more than 10m from the unit.



### WARNING

Use Bosch tanks and accessories to ensure compatibility with the unit.

On 200 l to 500 l storage tanks, a flanged solar pipe kit is available for on-site assembly. Whereas 1000 l tanks have a dedicated coil built in.

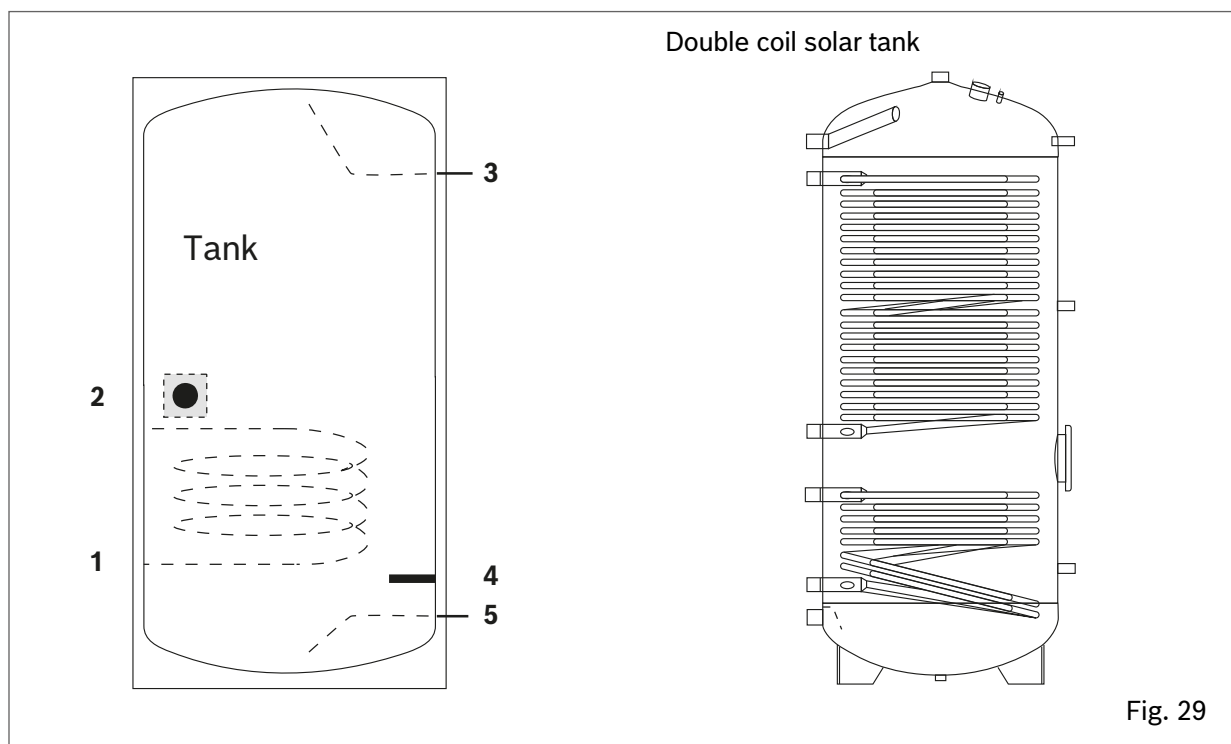

Fig. 29

Reference	Description
1	Heat exchanger
2	Temperature probe (accessory required for boiler management by the unit)
3	Outlet
4	Tank heater (to be installed under the temperature probe)
5	Inlet



### WARNING

The length of the pipe between the unit and the tank must be less than 10 meters.

Size		2.1 ~ 3.1	4.1 ~ 5.1	6.1 ~ 7.1 ~ 8.1	9.1 ~ 10.1 ~ 12.1 ~ 14.15
Tank volume / L	Recommended	100 ~ 250	150 ~ 300	200 ~ 1000	5000 ~ 1000
Heat exchanger size / m <sup>2</sup> (stainless steel)	Minimum	1.4	1.4	1.6	2.5
Heat exchanger size / m <sup>2</sup> (enamelled)	Minimum	2.0	2.0	2.5	3.5

## 5.7.2 Tank provided by a third party

---

When using a third-party tank, it must fulfil the following requirements:

- The tank thermistor must be placed above the heat exchanger coil.
- If possible, the additional heater should be located under the T5. In cases where this is not possible, always install a domestic hot water recirculation pump.
- Choose built-in heaters with double safety protection with manual and automatic reset thermostat in accordance with the requirements of EN 60335.



---

### WARNING

Third-party tank performance data cannot be provided and performance cannot be guaranteed. Use Bosch tanks and accessories for optimal performance.

---

---

### NOTE

The unit is standard supplied with a 10m long temperature probe. A probe of up to 30m long can be ordered as an accessory (**not recommended**).

---

## 5.8 Condensate drain

When a heat pump is running it produces a considerable amount of water due to the defrosting cycles of the external coil.

### NOTE

Condensate must be disposed of so as to avoid spillage over pedestrian areas.

With particularly cold and prolonged outdoor temperatures, the condensate could freeze outside the unit, blocking the flow and generating a gradually increasing built-up of ice; therefore, pay particular attention to the disposal of the condensate, raising the unit off the ground and considering the possibility of installing heating cables with an antifreeze function.

To prevent the water downstream of the drain from freezing, install the pipe below the frost line (E).

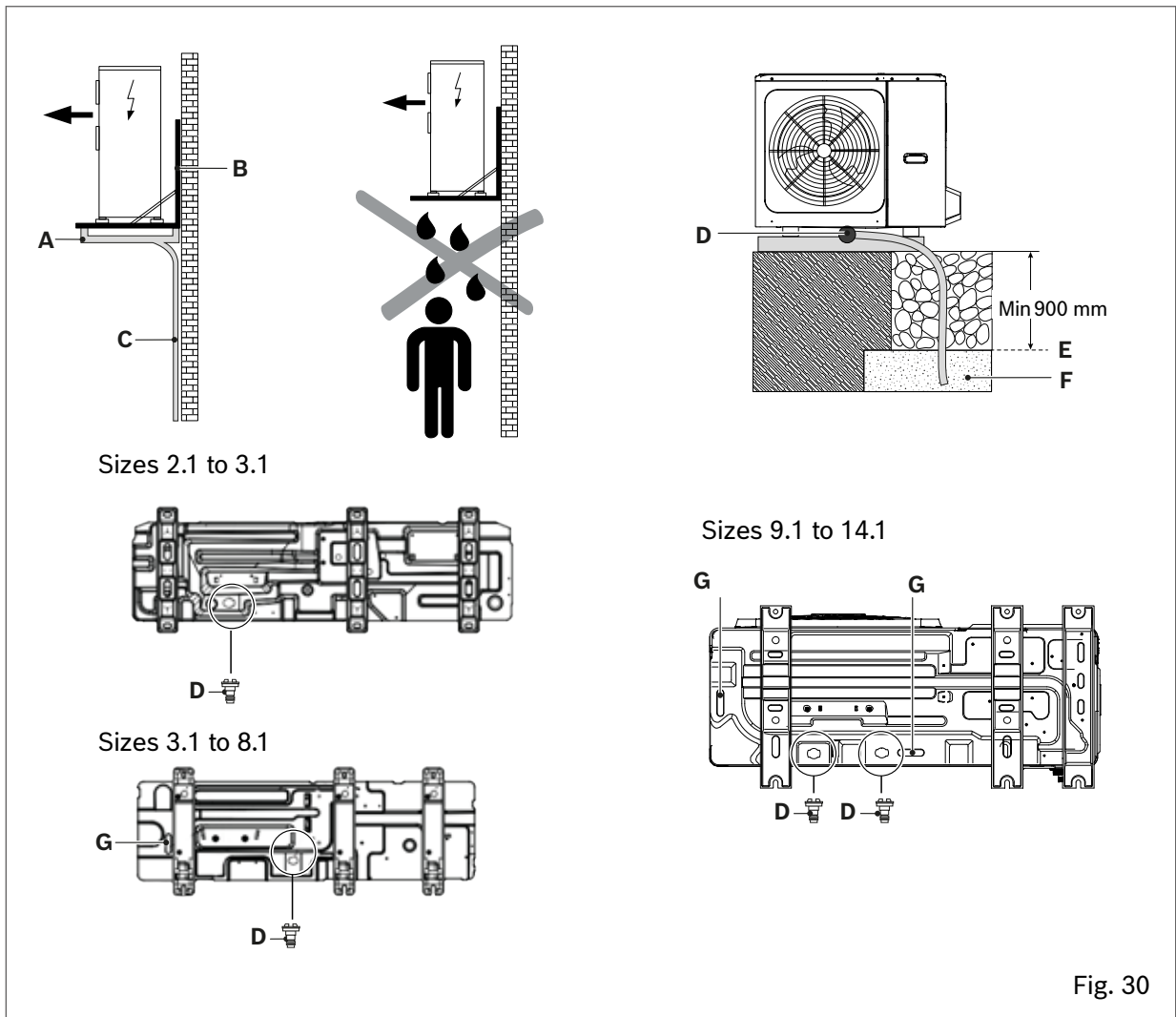

- A** DTX = Drain pan (accessory supplied separately)
- B** Unit mounting brackets (accessory supplied separately)
- C** Condensate drain pipe (to be provided by the customer)
- D** Condensate drain connection  $\varnothing 30$
- E** Frost line
- F** Layer of gravel or pebbles to help with condensate drainage
- G** The drain hole is covered by a rubber plug.

If the small drain hole is not sufficient, use it with the large drain hole.

## 6. Water connections

The unit has supply and return connections for connection to a water distribution system. Connection to the system must be carried out by authorised technicians and must comply with current laws and regulations.

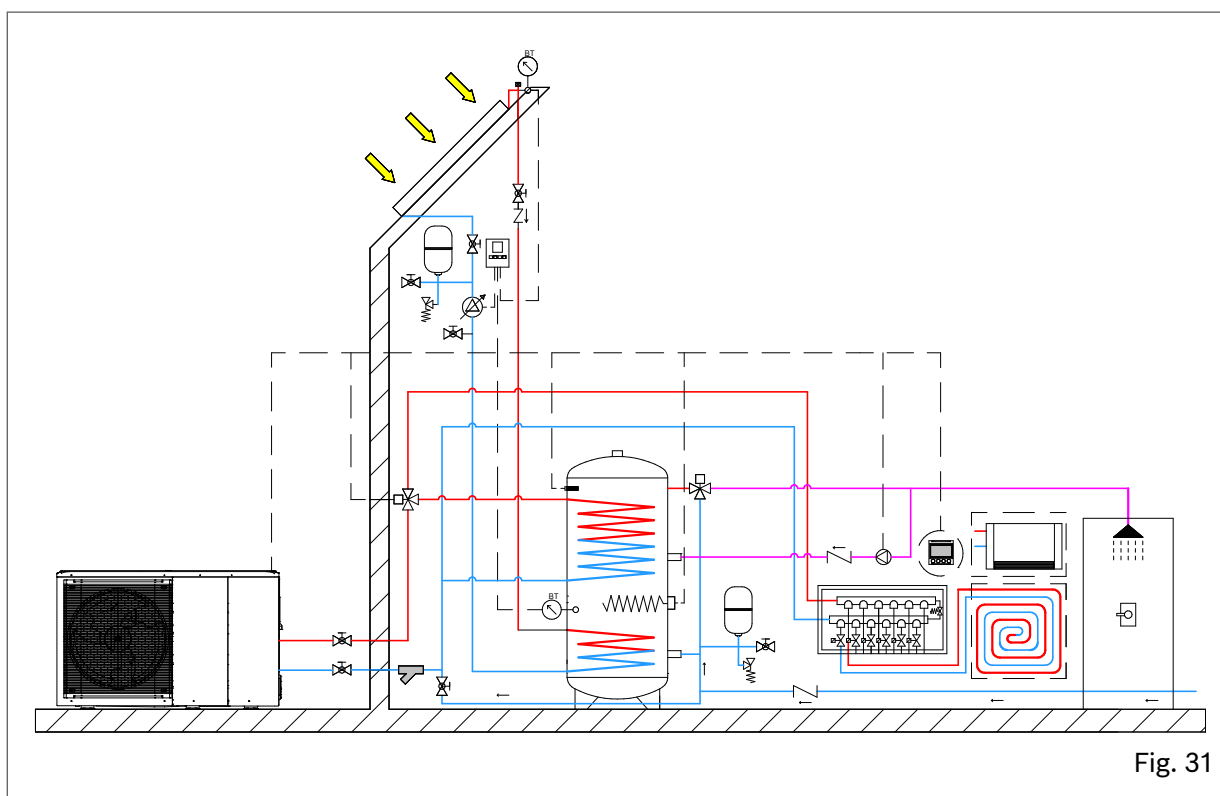

### 6.1 Preliminary check

#### 6.1.1 Water circuit

Before installing the unit, do a preliminary check and ensure the following:

- the water circuit inside the unit uses copper piping: do not use galvanised components in the system, as they may be subject to excessive corrosion;
- the maximum water pressure must be  $\leq 3$  bar;
- the maximum water temperature must be  $\leq 75^{\circ}\text{C}$ ;
- use system components that are compatible with the system water and the materials making up the unit;
- the pipes and system components to be installed must be suitable to withstand the pressure and temperature of the system water;
- shut-off valves must be installed at the lowest points of the system so that the circuit can be completely drained during maintenance;
- air vents must be installed at the highest points of the system, in places easily accessible to the Service technician. Inside the unit there is an automatic air vent for the water circuit: check that this is not over-tightened when charging the system, so that it can work effectively;
- the unit should only be connected to closed water circuits; connection to an open circuit can lead to corrosion of the water pipes.

## 6.1.2 Water characteristics

Circulators are designed to operate optimally only with clean, good quality mains water and may be affected by the presence of oxygen, limescale, sludge, abnormal acidity levels and other substances (including chlorides and minerals). The same can be said for the plate heat exchanger. Excessive water hardness can create deposits and limescale build-up that can damage the unit. The presence of critical concentrations of other components in the circuit can trigger corrosive processes or other quality problems in the circulator and plate heat exchanger. Check that the system water complies with the concentration limits given in the table.



### CAUTION

If the water hardness is too high, assemble a water softener to reduce the value.



### CAUTION

The heating system must be airtight and materials must be chosen that are not sensitive to oxygen diffusion (which can cause corrosion).

Characteristics	Water component for corrosion limit on Copper
pH (25°C)	7.5 to 9.0
SO <sub>4</sub> <sup>-</sup>	< 100
HCO <sub>3</sub> <sup>-</sup> / SO <sub>4</sub> <sup>--</sup>	> 1
Total Hardness	8 to 15 °f (4.5-8.5 dH)
Cl <sup>-</sup>	< 50 ppm
PO <sub>4</sub> <sup>3-</sup>	< 2.0 ppm
NH <sub>3</sub>	< 0.5 ppm
Free Chlorine	< 0.5 ppm
Fe <sub>3</sub> <sup>+</sup>	< 0.5 ppm
Mn <sup>++</sup>	< 0.05 ppm
CO <sub>2</sub>	< 50 ppm
H <sub>2</sub> S	< 50 ppm
Temperature	< 65 °C
Oxygen content	< 0.1 ppm
Sand	10 mg/L 0.1 to 0.7mm max diameter
Ferrite hydroxide Fe <sub>3</sub> O <sub>4</sub> (black)	Dose < 7.5 mg/L 50% of mass with diameter < 10 µm
Iron oxide Fe <sub>2</sub> O <sub>3</sub> (red)	Dose < 7.5mg/L - Diameter < 1 µm

## 6.2 General system requirements (to be provided by the customer)

### 6.2.1 Air vent valves

Provide vent valves at all high points of the system to allow air to escape from it.

### 6.2.2 Water filter on Domestic Hot Water side

Install a filter to capture any water impurities, to avoid clogging the system and the exchanger, which should be installed immediately at the mains water inlet and in a position easily accessible for cleaning. The filter is to be provided by the customer, installed on site, never removed and periodically checked for clogging.

### 6.2.3 System side water filter

It is mandatory to install a filter on the return line of the system in order to maintain optimal operation of the unit.

The mesh filter standard supplied with the unit should never be removed and periodically checked for clogging.

In addition to the filter supplied, we recommend installing a dirt separator filter to trap not only general dirt, but also fine ferromagnetic particles and parts dispersed during use that are not trapped by the mesh filter. If both are present, place the mesh filter upstream on the return line.

Compatibly with the need to limit pressure drops, having a double filter of different types in series will protect the unit better from dirt and impurities in the carrier fluid.

## 6.3 Water pipes

The water circuit connections must be done correctly and in accordance with the unit's specifications, respecting the water entering and leaving.

The system must always meet the minimum requirements for water quantity and quality and be protected from sludge, contaminants and encrustations.

### 6.3.1 General instructions for piping

Always take the following into consideration when connecting the water circuit:

- use only clean pipes: air, humidity, dirt or dust can cause problems;
- keep the end of the pipe downwards when removing burrs;
- cover the end of the pipe when inserting it through a wall to prevent dust and dirt from entering;
- use a good thread sealant to seal the connections. The seal must be able to withstand the pressures and temperatures of the circuit;
- when using non-copper metal piping, isolate the two types of materials from each other to prevent galvanic corrosion;
- pay attention not to deform the pipes by using excessive force or unsuitable tools during connection: this could cause the unit to malfunction.

**Unsuitable tools can damage the pipes.**

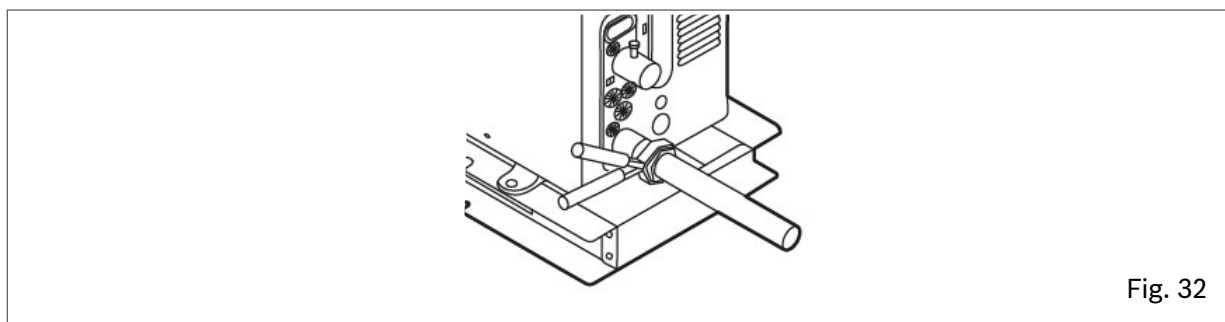

Fig. 32

### 6.3.2 Installing a water filter

---

The unit can also be seriously damaged by impurities in the water: welding residues, slag, mineral oil, sludge, dirt, etc.

One option to limit pollutants in the water is to install a filter, which is always necessary.

Various types of filters can be used:

- mesh filter (mandatory on DHW circuit and system side), designed to trap large dirt particles and usually positioned in the part of the circuit with the highest flow-rate;
- fabric filter, designed to trap the finer particles;
- magnetic dirt separator filter (mandatory on system circuit), designed to trap sludge and ferrous residues. Before connecting the water to the unit, clean the system thoroughly with specific and effective products to remove residues or impurities that could affect operation.

### 6.3.3 Magnetic dirt separator filter

---

It is highly recommended to install the magnetic dirt separator filter on the system circuit, it is advisable to use the filter supplied by Bosch or equivalent.

### 6.3.4 Installation in new systems

---

During installation, residues (welding, slag, joint products, etc.) or preservatives (e.g. mineral oil) can build up in the circuit.

Before start-up, in new installations it is therefore essential to thoroughly flush the entire system.

It is important to empty the water circuit completely when cleaning to prevent corrosive or aggressive components remaining in the final charge.

The system must then be filled with clean, good quality mains water after checking that the downstream filters are clean.

If necessary, clean several times until the filters become clean.

### 6.3.5 Installation in existing systems

---

If the unit is to be installed in an existing system, the system must be thoroughly flushed to remove particles, sludge and slag.



#### CAUTION

Drain the system before the new unit is installed.

Dirt can only be removed with an adequate water flow-rate: so each section must be washed separately. Particular attention must be paid to “blind spots”, where due to the low flow-rate a lot of dirt can accumulate. The system must then be filled with clean, good quality mains water.

After rinsing, check the quality of the water in the system: if it is inadequate, further measures must be taken to avoid problems.



#### CAUTION

The warranty does not cover damage caused by limescale build-up, deposits and impurities deriving from the water supply and/or failure of the system cleaning process.

## 6.4 Water circuit frost protection

The unit is designed to be installed outdoors and can therefore be exposed to sub-zero temperatures: it is necessary to prevent ice from forming in the water circuit, which can cause serious damage.



### CAUTION

Damage from freezing is not covered by the warranty.

If the unit is not started for a long time, make sure it remains powered and on stand-by. When the unit is on stand-by, the software uses special functions that activate the heat pump to protect the whole system from freezing. When the temperature of the water in the circuit falls below a certain value, the unit will heat the water by activating the circulation or the additional electric heater. The freeze protection function is only disabled when the temperature rises above a threshold that does not pose any risks to the system.

In the event of a blackout or power failure, the above freeze protection functions cannot be activated. For applications where there is a risk of freezing, it is advisable to provide an antifreeze liquid or an automatic frost protection valve to be fitted in the water circuit. It is advisable to opt for the solution proposed by the supplier and to pay attention to the accessory's manual.

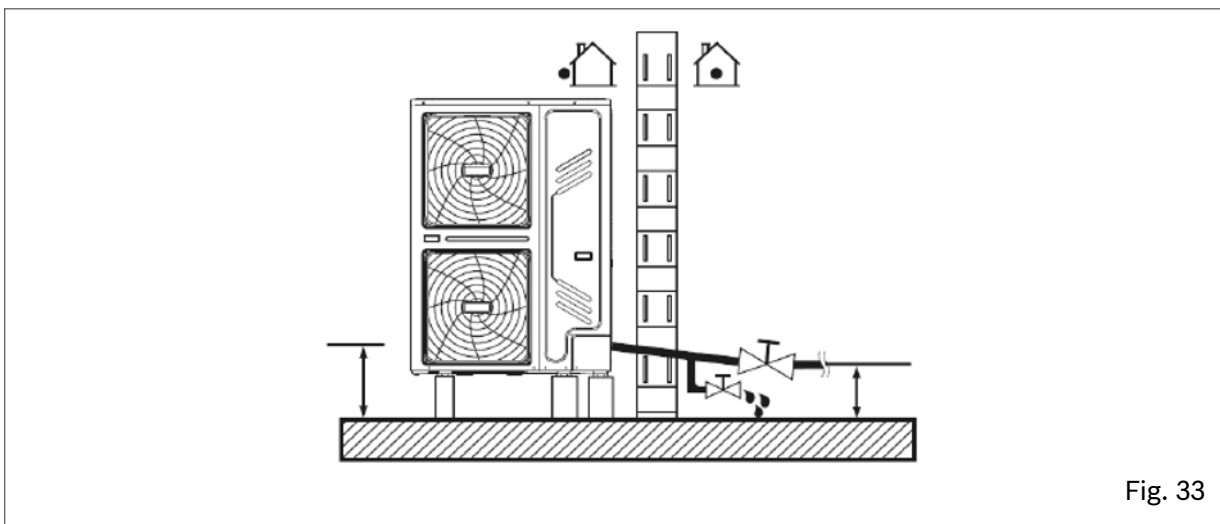

Fig. 33



**CAUTION** If the power supply has to be disconnected, the water in the circuit must be completely drained so that the unit and pipes are not damaged by freezing. Do not restart the unit if there is no water in the circuit.

To protect the unit from icing up:

- protect the pipes: all the internal parts of the unit's water circuit are insulated to reduce heat loss; insulation must also be provided for the pipes to be installed on site. It is advisable to provide pipes with heating cables placed underneath the insulation.

### 6.4.1 Using an antifreeze liquid

The recommended antifreeze fluid is glycol, which, depending on its concentration in the water, can lower the freezing temperature.

A generic system can use ethylene glycol or propylene glycol (category III according to EN1717, with inhibitors), while systems with DHW storage tank require only propylene glycol.

The presence of glycol in the system may make it necessary to install an additional expansion tank. Take this into account in installation assessments.

Depending on the minimum expected outdoor temperature, put a concentration of glycol into the water circuit as per the table below.

The use of glycol changes performance of the unit: the operating performance can be estimated by multiplying the correction factors by the nominal operating values.

**Ethylene glycol table**

MIN outdoor temperature	Glycol concentration	Correction factors			
		Cooling capacity	Power input	Water resistance	Water flow
0 °C	0%	1	1	1	1
-5 °C	10%	0.984	0.998	1.118	1.019
-15 °C	20%	0.973	0.995	1.268	1.051
-25 °C	30%	0.965	0.992	1.482	1.092

**Table for propylene glycol**

MIN outdoor temperature	Glycol concentration	Correction factors			
		Cooling capacity	Power input	Water resistance	Water flow
0 °C	0%	1	1	1	1
-4 °C	10%	0.976	0.996	1.071	1
-12 °C	20%	0.961	0.992	1.189	1.016
-20 °C	30%	0.948	0.988	1.380	1.034

**NOTE**

Depending on the type of glycol selected, the concentrations may differ from the values in the tables. Always compare these requirements with the glycol supplier's specifications and use the actual specification values of the product used. The glycol concentration must never be > 30%.

**CAUTION**

Glycol is a toxic fluid and should not be discharged freely: it must be collected and possibly reused. It must contain inhibitors so that it does not become acidic in contact with oxygen: in the presence of copper and at high temperatures this happens quickly.

Uninhibited acid glycol attacks metal surfaces and forms galvanic corrosion cells that cause severe damage to the system.

Carefully check that:

- the glycol is compatible with the materials used in the system;
- water treatment is carried out correctly by a qualified specialist;
- the glycol chosen has corrosion inhibitors to counteract the acids formed by oxidation;
- only propylene glycol is used in installations with Domestic Hot Water tanks;
- no automotive glycol is used (corrosion inhibitors have a limited lifespan and contain silicates that can damage or clog the system);
- galvanised pipes are not used in glycol systems, as they can cause certain components of the glycol corrosion inhibitors to break down;
- no mixtures of different types of glycol (e.g. ethylene and propylene) are used.

**NOTE**

Glycol absorbs humidity from its environment, reducing its concentration. If glycol is used, duct the pressure relief valve in accordance with the regulations in force, taking into account its toxicity and associated risks. Avoid exposing glycol to air as much as possible and do not use glycol that has been exposed (e.g. glycol container left open), it may not adequately protect against freezing.

## 6.4.2 Using automatic frost protection valves

Automatic frost protection valves are available as an accessory and drain water from the circuit, preventing freezing.

Depending on the higher activation temperature of the frost protection valves, it may be necessary to adjust the minimum Cooling setpoint: carefully set it at least 2 °C higher than the minimum allowed (minimum default cooling setpoint = 5 °C; recommended minimum setpoint with freeze protection valves = 7 °C) to prevent the valves from draining the system when it is operating in Cooling mode.



### CAUTION

In the presence of water with glycol, do not use frost protection valves as they may drain it from the circuit. It is recommended to:

- install valves at all low points of the system (see the valve kit manual for further details on installation);
- provide normally closed valves, installed inside but as close as possible to the unit's water connections, so as not to unnecessarily drain the entire system when the frost protection valves activate.

Refer to the frost protection valve kit manual for further details.

## 6.4.3 Protection of flow switch against frost

When the system is drained (manually or with an automatic frost protection valve), some water may remain in the flow switch and not be drained by activation of the valves: at sufficiently low outdoor air temperatures it can freeze. The flow switch must be removed and dried following the procedure below, and then reinstalled in the unit.

Turn the flow switch anticlockwise and remove it, dry it carefully and then put it back in its original position.

### Sizes 2.1~8.1

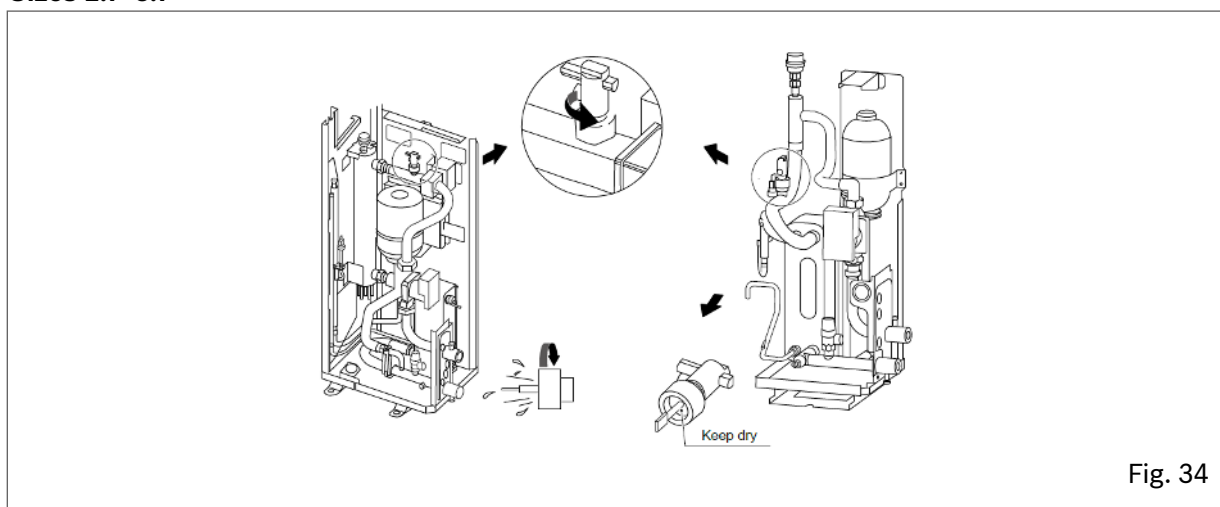

It is advisable to carry out this operation every time the system is emptied and at the beginning of the winter season if the unit is used as a process chiller (operation in cooling mode even in winter).

**Sizes 9.1~14.1**

Fig. 35

### 6.4.4 Protection of Domestic Hot Water storage tank

When the storage tank is full, the house may not be inhabited immediately or the unit may be left off for long periods.

In such cases it is always advisable to empty the tank to avoid water stagnation or, at sufficiently low temperatures, freezing.

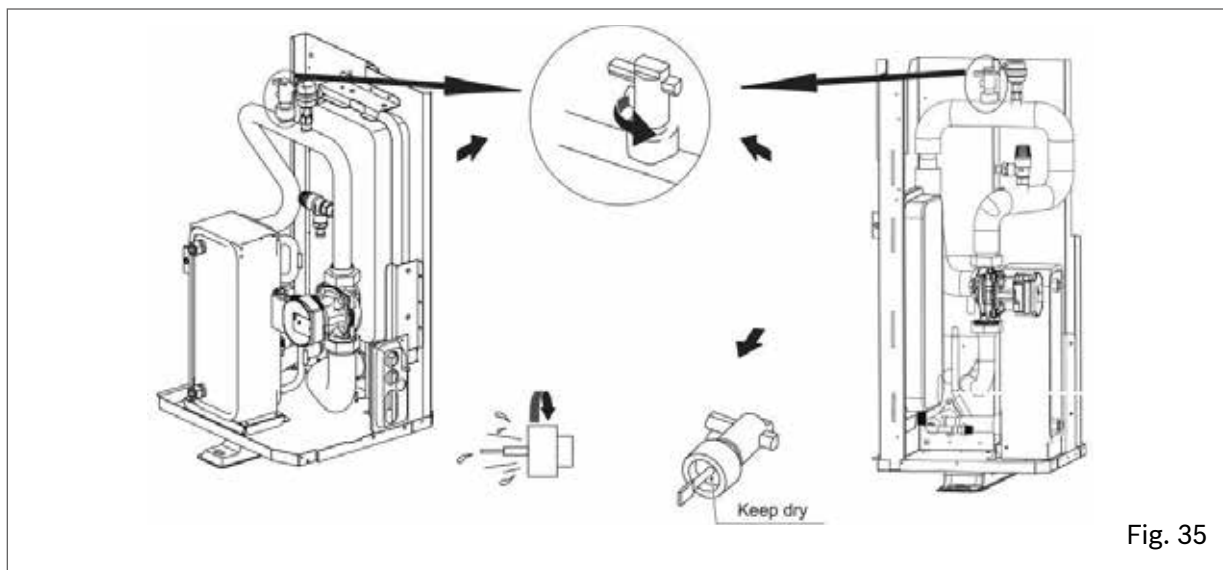
Do not supply the storage tank heaters with electricity if the storage tank is not full. Refer to the specific storage tank instructions for all other details when using the manufacturer's accessories.

## 6.5 Pipe insulation

All the water circuit pipes must be insulated to prevent condensate from forming during cooling mode operation, reduction of the delivery capacity and freezing of the pipes outside during winter.

The insulation material must be selected according to the requirements in the table below and be at least class B1 fire resistant and comply with current regulations.

Pipe length (m)	Minimum insulation thickness (mm)
<20	19
20 ~ 30	32
50 ~ 40	40
40 ~ 50	50

**CAUTION**

To prevent outdoor pipes from freezing, the insulation thickness must be > 13mm and have a thermal conductivity of  $\lambda=0.039$  W/mK. If the outdoor temperature is likely to be > 30°C and relative humidity > 80%, a thickness of > 20mm should be used to prevent condensate on the outer surface of the insulation.

## 6.6 Water volume, system pressure and expansion tank control

Check that the system has the minimum water content.

The total volume of water, excluding that contained in the unit, must exceed the values in the table:

Size	2.1 to 3.1	4.1 to 8.1	9.1 to 14.1
MIN water volume	30l	70l	100l

In most applications, this volume of water will be sufficient; however, in process applications or in environments with high thermal load, additional water may be required.

### NOTE

When the system has zones with remotely controlled valves, the minimum volume of water must be guaranteed even when all valves are closed.

### 6.6.1 System pressure and expansion tank control

The units are equipped with an 8-litre expansion tank (with an available volume of 4.8 litres) which has a pre-charge pressure of 1 bar, sized to suit the total water content of the most common systems.

When serving systems with a high water content, the expansion tank volume may not be sufficient and the pre-charge pressure must be adjusted or an additional expansion tank must be provided.

### 6.6.2 Sizes 2.1 to 8.1

It is not necessary to adjust the pressure of the standard supplied expansion tank as the water content of the system changes, but it may be necessary to add an additional expansion tank.

Based on the water content of the system, calculate the total volume required for the expansion tank  $V_{EXP. VESSEL}$ :

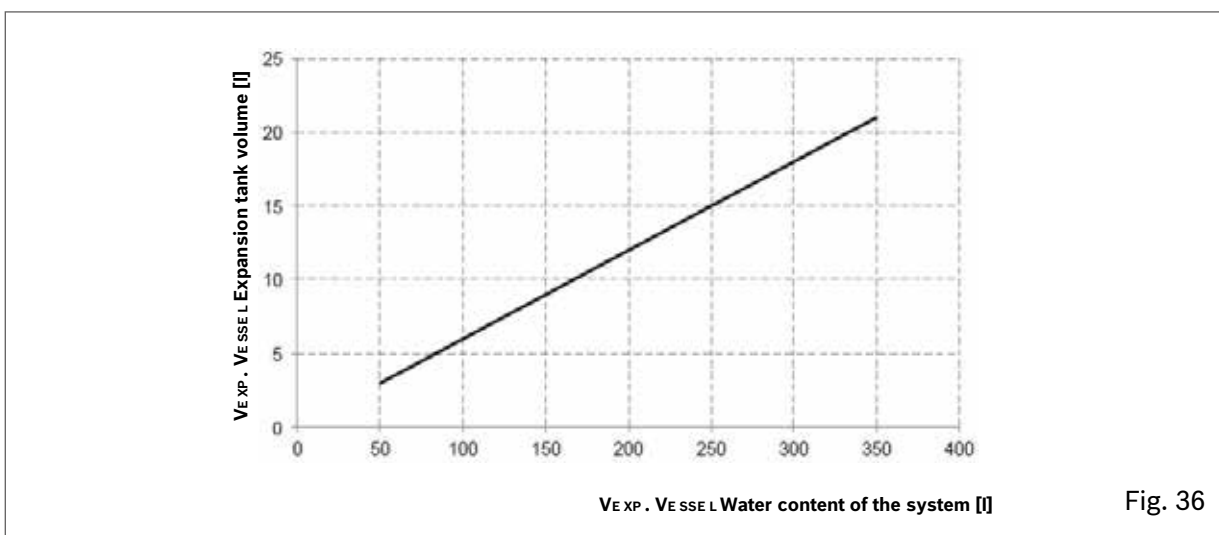

Fig. 36

The volume of the additional expansion tank must be:  $V_{ADDITIONAL} = V_{EXP. VESSEL} - 4.8$  [l]

### NOTE

The additional expansion tank must be set to 1 bar.

### 6.6.3 Sizes 9.1 to 14.1

Depending on the operating conditions, the preset pressure may need to be adjusted on site.

Measure the system height difference H: the difference in height in metres between the highest point of the water circuit and the unit. If the unit is located at the highest point of the system, consider 0m.

Adjust the pressure according to the diagram in the table:

H system height difference [m]	Water content [l]	
	≤ 230l	> 230l
≤ 7m	No adjustment required	The pressure of the expansion tank must be reduced.  Adjust to P <sub>g</sub> value
> 7 m	The pressure of the expansion tank must be increased.  Adjust to P <sub>g</sub> value	The unit's expansion tank is not sufficient, add an additional tank.  The pressure of all expansion tanks must be adjusted to the P <sub>g</sub> value

The P<sub>g</sub> pressure to which the expansion tank should be set can be calculated with the formula:  $P_g = 0.3 + (H/10)$  [bar]

#### NOTE

If the expansion tank pressure needs to be adjusted, contact an authorised technician and use only dry nitrogen. Inadequate expansion tank pressure adjustment can cause the system to malfunction.

Check that the system complies with the maximum water content (with standard expansion tank only). To determine the maximum water content of the system that can be managed with the standard expansion tank alone, use the following graphs:

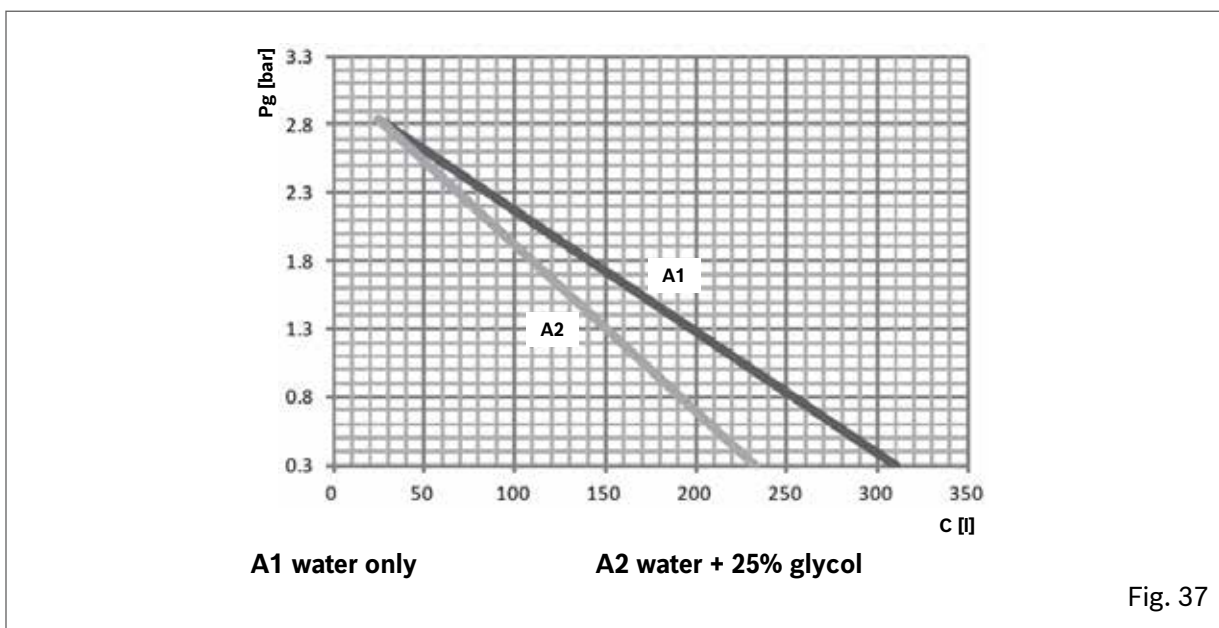



The total volume of water in the system must be less than that indicated, otherwise an additional expansion tank will be required.

The additional expansion tank must be adjusted to the  $P_g$  pressure and must have a volume sized with the formula:

$$V_{ADD} = 0.0693 \times (V_{SYS} / (2.5 - P_g)) - V_{STD} \quad [l]$$

$V_{ADD}$ : additional expansion tank volume

$V_{SYS}$ : system water volume

$V_{STD}$ : volume of the expansion tank supplied with the unit

### Example 1:

Unit 8.1, installed 5m below the highest point of the water circuit  $\rightarrow H = 5m$

Total volume of water in the water circuit of 150l

respects the minimum water content (40l)

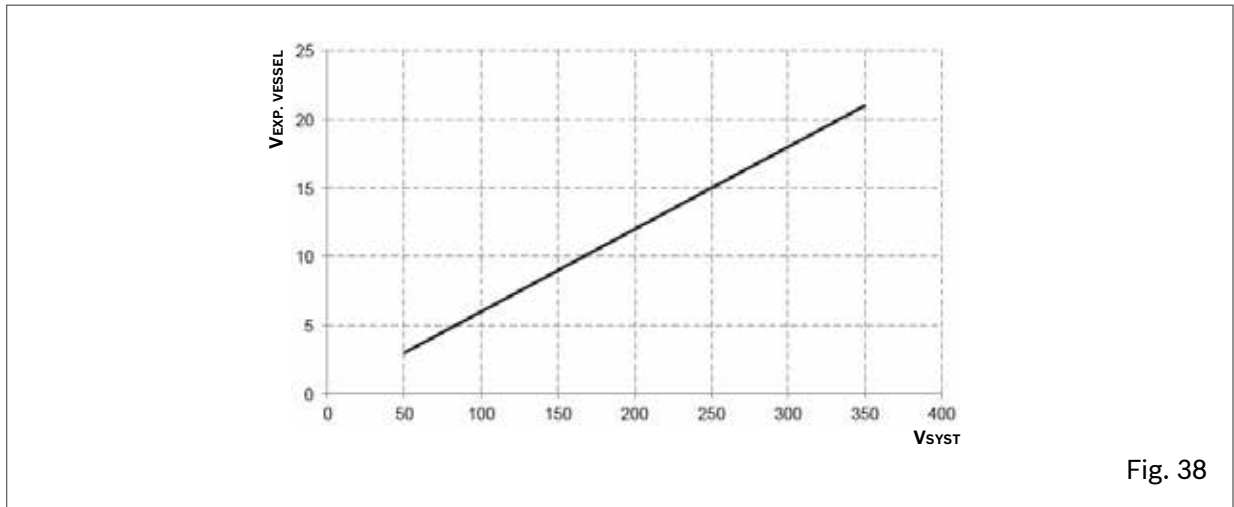

Fig. 38

$$V_{ADDITIONAL} = V_{EXP. VESSEL} - 4.8 \quad [l] = 9 - 4.8 = 4.2l \rightarrow \text{additional } 4.2l \text{ expansion tank required}$$

### Example 2:

Unit 10.1, installed at the highest point of the water circuit  $\rightarrow H = 0m$

Total volume of water in the water circuit of 250l

$$P_g = 0.3 + (0/10) = 0.3 \text{ bar}$$

respects the minimum water content (60l)

$H \leq 7m$  - Water content  $> 230l$   $\rightarrow$  expansion tank should be adjusted to the  $P_g$  pressure

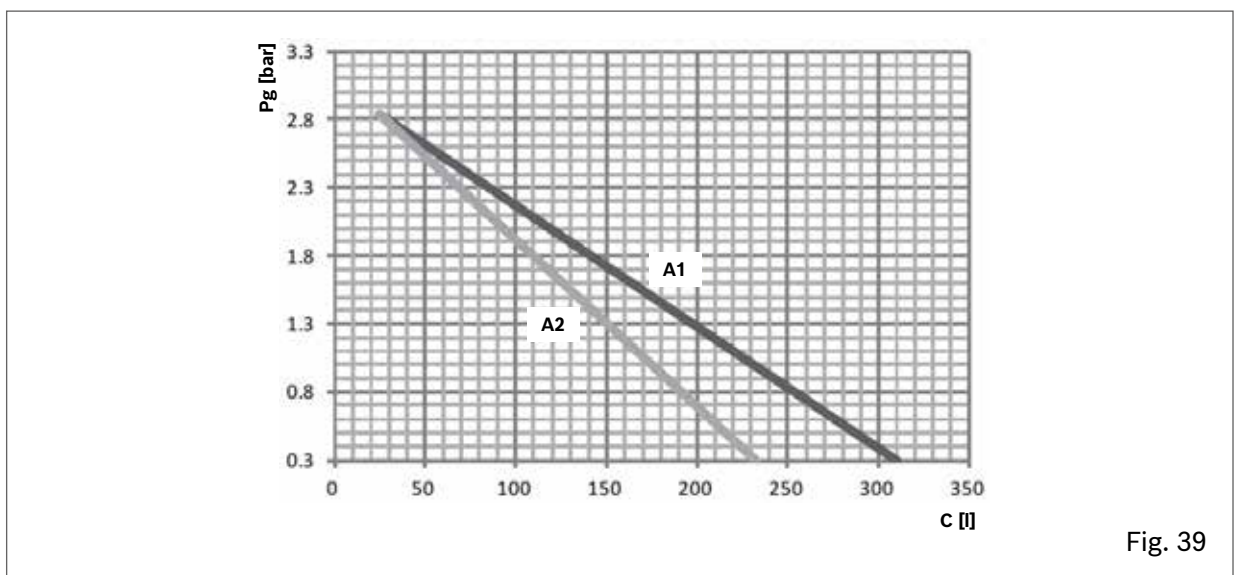

Fig. 39

Maximum water content: 310l  $\rightarrow$  respects the maximum water content



### 6.7 Filling / topping up with water

The unit requires the system to be filled with water before start-up or may need to be topped up in special cases. In both cases follow the procedure:

- connect the water supply to the filling valve and open the valve;
- check that the automatic air vent valve is open (at least 2 turns);
- fill with water until the pressure gauge indicates a pressure of approx. 1.8 bar;
- air in the circuit could cause a malfunction of the additional heater: discharge as much as possible through the vent valve.



#### CAUTION

If present, the DHW storage tank should only be filled when starting the unit.

#### NOTE

When the system is in operation, do not fasten the black plastic cover on the vent valve on the top of the unit. Open the air purge valve, turn at least 2 full turns anticlockwise to discharge air from the system.

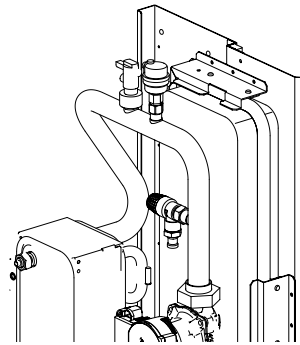

Fig. 40

#### NOTE

During filling, it may not be possible to discharge all the air from the system: the residual air will be discharged through the automatic vent valves during the first hours of system operation. It may therefore be necessary to top up the system water when the unit is switched off. The water pressure indicated on the pressure gauge varies according to its temperature: water at a higher temperature will have a higher pressure. Keep the water pressure always > 0.3 bar to prevent air from entering the system.

The unit may discharge water through the pressure relief valve. Check the system pressure periodically.

## 7. Electrical connections



---

### WARNING

- The fixed wiring must include a magnetothermic circuit breaker or other means of isolation with contact separation on all poles, to be implemented in accordance with the laws and regulations in force.
  - The protection must be sized in accordance with the electrical data declared by the manufacturer.
  - Disconnect the power supply before making any connections and wait 10 minutes so that the DC bus condensers of the compressor's inverter are correctly at a low residual voltage.
  - Only use copper cables.
  - Do not crush cable bundles and prevent them from coming into contact with pipes and any sharp edges.
  - Installation of electrical components and connections on site must be carried out by a qualified electrician and in accordance with the laws and regulations in force.
  - On-site electrical connections must be made in accordance with the wiring diagram supplied with the unit and following the instructions below.
  - Use a dedicated power supply. Never use a power supply that is also used by other equipment.
  - Earth the unit.
  - Do not connect the earth wire to gas or water pipes, lightning rods or telephone system earth cables.
  - Incorrect earthing may cause electric shocks.
  - Install an earth leakage differential circuit breaker (30 mA).
  - Failure to observe this precaution may result in electric shock.
  - Install the necessary fuses or circuit breakers.
  - Power and signal cables should be routed as separately as possible to avoid possible interference. Where ducted in parallel, for convenience observe the following distances: 300 mm for rated currents below 10 A and 500 mm for rated currents between 10 and 50 A.
-

## 7.1 Precautions for electrical connections

---

Follow the precautions below before making electrical connections:

- Secure electric cables with cable ties so that they do not come into contact with the pipes (especially avoid contact with the refrigeration circuit pipes on the high pressure side).
- Ensure that no external force is exerted on the terminal connectors.
- When installing the earth leakage circuit breaker, make sure it is compatible with the inverter (resistant to high frequency electromagnetic interference) to avoid unnecessary tripping of the switch.
- If a 3-way valve is required in the system, it is advisable to use the kit supplied as an option. However, it is preferable to choose a ball type to ensure complete separation between the domestic hot water circuit and the system circuit. In any case, low-leakage valves should be used. When using a 2- or 3-way valve in the circuit, it is advisable for its maximum switching time to be less than 60 seconds. 30 s switching time is recommended;



---

### WARNING

The differential circuit breaker must be a 30 mA (<0.1 s) fast tripping type.

---

This unit is equipped with an inverter.

The installation of a power-factor condenser not only disturbs the improving effect that such a device has on the power factor, but can also cause the condenser to overheat due to high-frequency waves.

It is therefore recommended not to install a power-factor condenser in order to avoid possible accidents.

## 7.2 General diagram

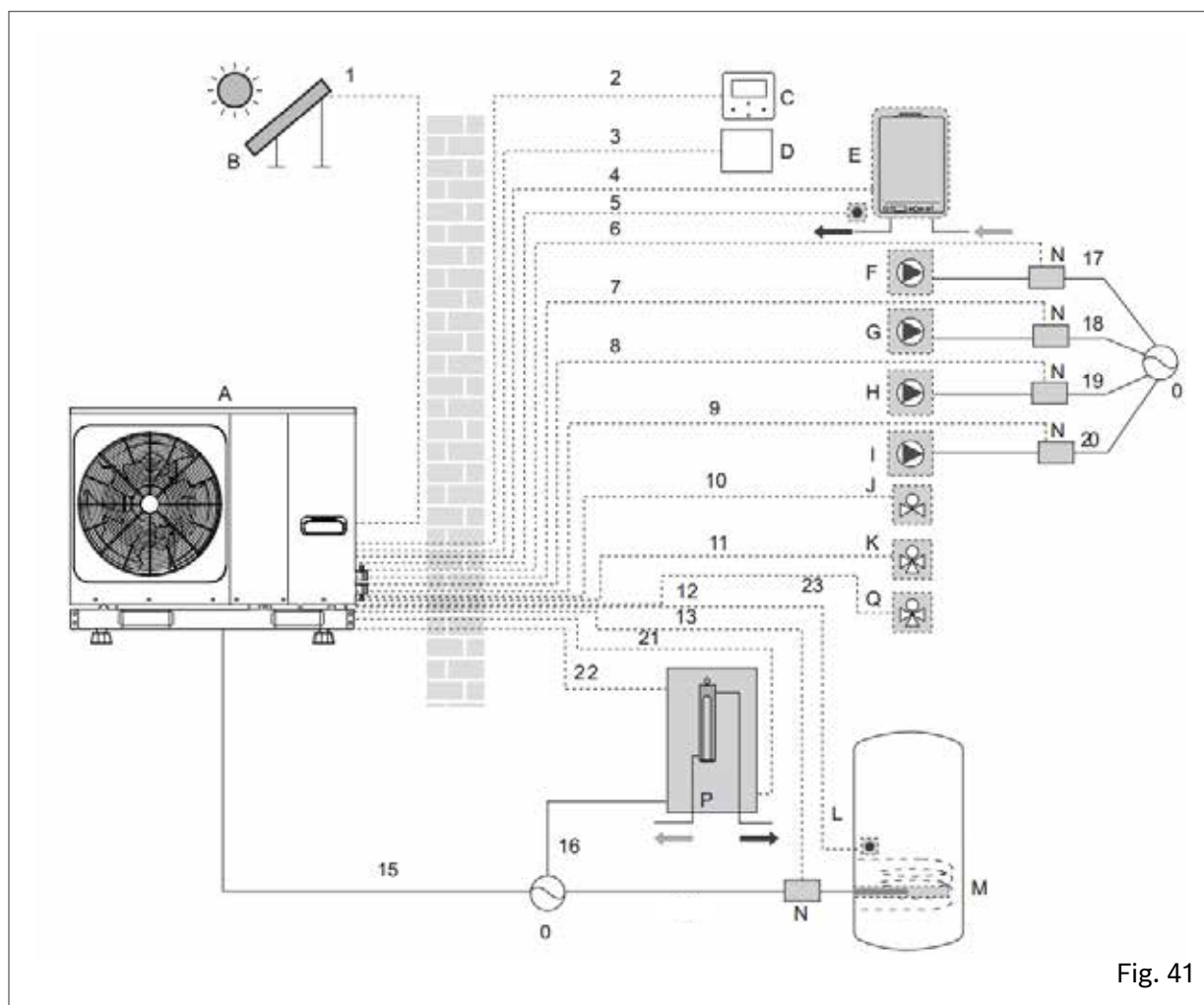

Fig. 41

Ref.	Description	Ref.	Description
A	Unit	I	DHW recirculation pump (not supplied)
B	Solar kit (not supplied)	J	3-way valve (not supplied)
C	User interface	K	3-way valve for domestic hot water storage tank (not supplied)
D	Room thermostat (not supplied)	L	Domestic hot water storage tank (not supplied)
E	Boiler (not supplied)	M	Booster heater (not supplied)
F	Solar pump (not supplied)	N	Counter
G	Mixed zone booster pump	O	Power supply
H	External recirculation pump (not supplied)	P	Backup heater
Q	Zone 2 3-way valve (not supplied)		

Ref.	Description
1	Solar kit signal cable
2	User interface cable
3	Room thermostat cable
4	Boiler control cable
5	Thermistor cable for Tw2
9	Domestic hot water pump control cable
10	2-way valve control cable
10 11 23	3-way valve control cable
12	Thermistor cable T5
13	Booster heater control cable
14	Contactora power supply for domestic hot water storage tank electric heater.
15	Unit power cable
16	Backup heater power cable
17	Solar pump power supply
18	Mixed zone booster power supply
19	Zone 1 (unmixed) booster pump power supply
20	Domestic hot water circulation pump power supply
21	Backup heater consent signal
22	Backup heater temperature reading probe

**WARNING**

All cables are connected to high-voltage lines with the exception of the thermistor cable and user interface cable.

- The appliance must be earthed.
- All external high-voltage loads, if connected to a metal socket or earthed port, must be earthed.
- The current required for each external load must be less than 0.2 A. If the current required for a single load is greater than 0.2 A, insert a contactor for control.
- As an example, the ports on terminals “AHS1” “AHS2”, “A1” “A2”, “R1” “R1” and “DTF1” “DTF2” only provide the switching signal.
- Refer to “7.5.3 Connection terminal block” on page 58 for the location of the ports in the unit.

## 7.3 Control box

### 7.3.1 Sizes 2.1 to 8.1

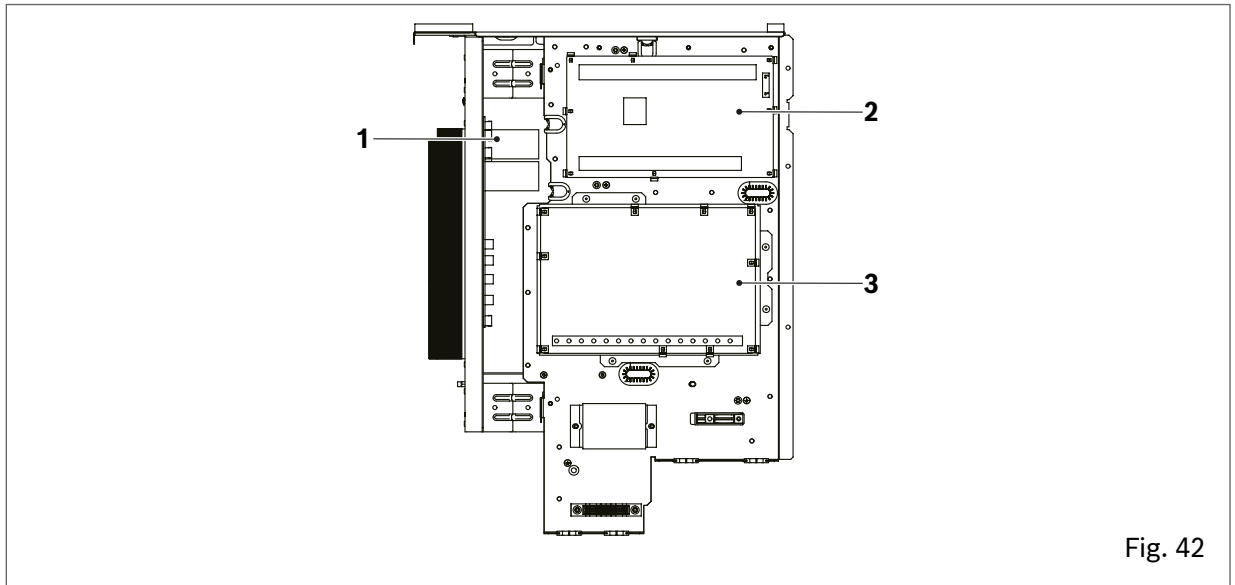

Fig. 42

- 1 Inverter module (PCB A)
- 2 Main control board (PCB B)
- 3 Hydraulic module control board

*The picture of the control box is for reference only.*

### 7.3.2 Sizes 9.1 to 14.1

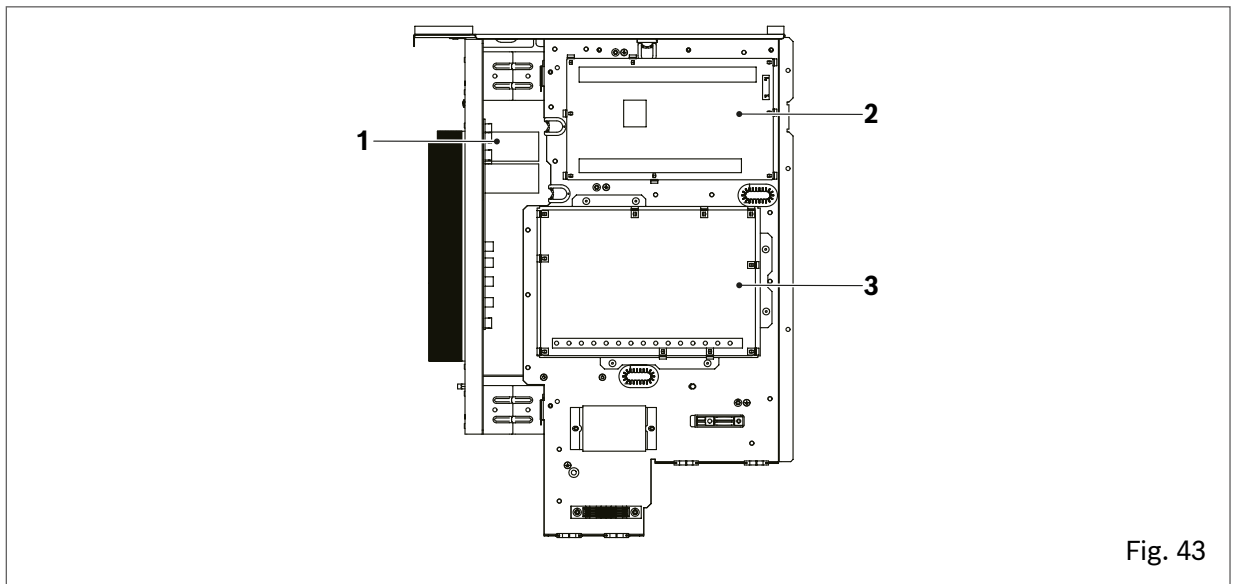

Fig. 43

- 1 Inverter module (PCB A)
- 2 Main control board (PCB B)
- 3 Hydraulic module control board

*The picture of the control box is for reference only.*

## 7.4 Location of connections

### 7.4.1 Sizes 2.1 to 3.1

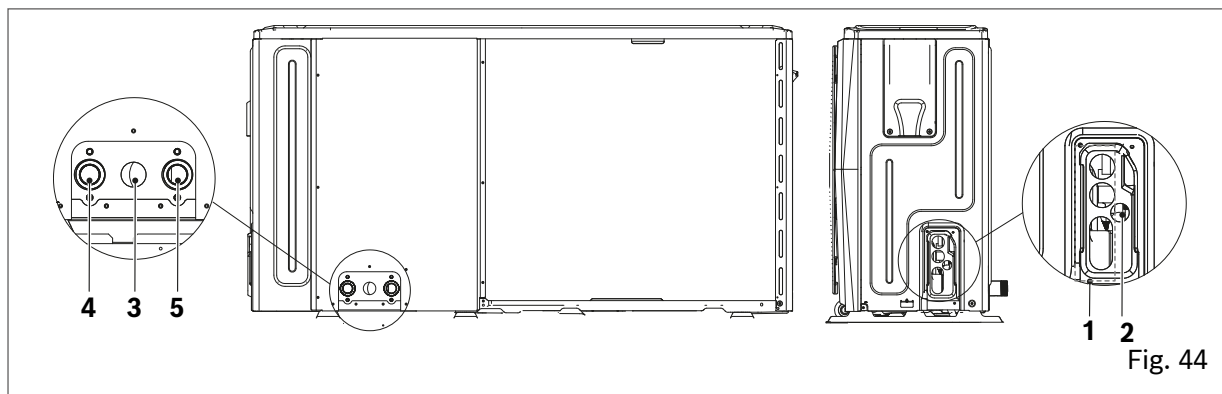

- 1 Hole for high voltage cable (power supply)
- 2 Hole for low voltage cable (control and signal cables)
- 3 Hole for drain pipe
- 4 Water outlet
- 5 Water inlet

### 7.4.2 Sizes 4.1 to 8.1

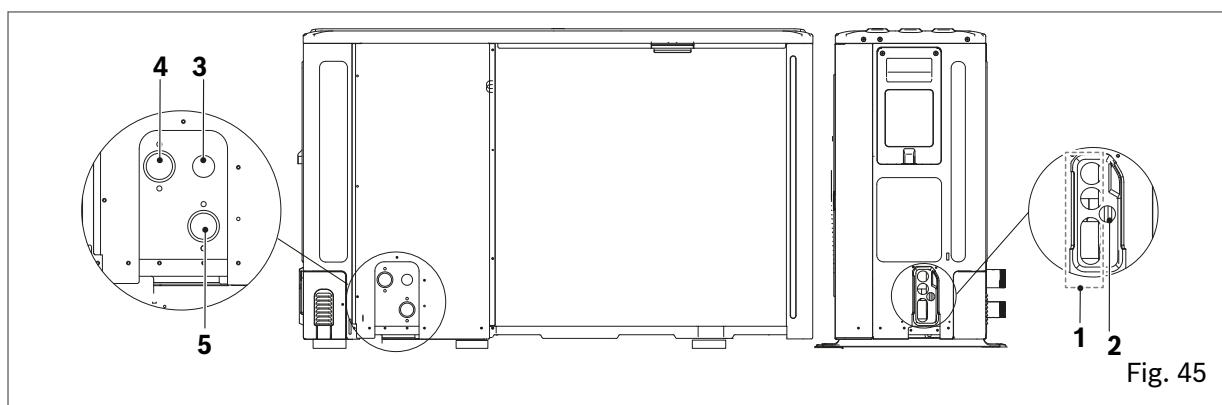

- 1 Hole for high voltage cable (power supply)
- 2 Hole for low voltage cable (control and signal cables)
- 3 Hole for drain pipe
- 4 Water outlet
- 5 Water inlet

## 7.4.3 Sizes 9.1 to 14.1

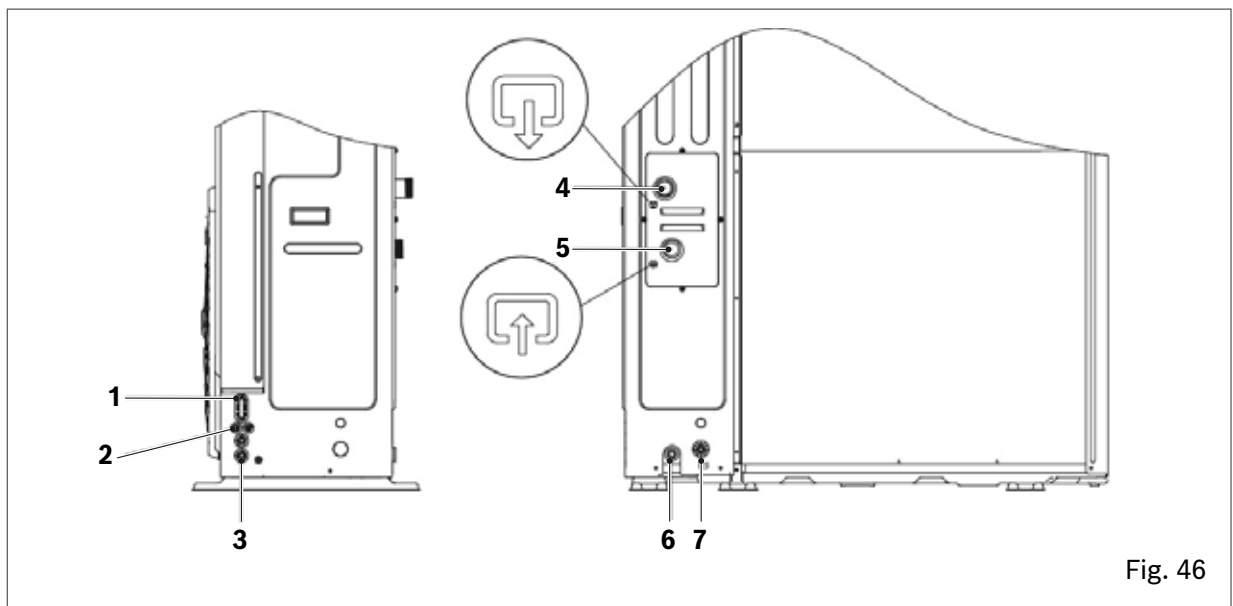

Fig. 46

- 1 Hole for high voltage cable (power supply)
- 2 Hole for low voltage cable (control and signal cables)
- 3 Hole for high/low voltage cable
- 4 Water outlet
- 5 Water inlet
- 6 Hole for drain pipe
- 7 Hole for pressure relief valve drain pipe

**NOTE**

Most of the electrical connections to be done on site are to be performed on the terminal block inside the control box. To access the terminal block, remove the service panel from the control box and wait 10 minutes for the DC bus condensers of the compressor's inverter to discharge.

**CAUTION DANGER**

Before removing the service panel from the control box, disconnect the power supply to the unit, the backup heater, the domestic hot water storage tank and all the other electrically powered components.

**WARNING**

- Secure cables with cable ties
- The external backup heater requires a dedicated electric circuit.
- Installations with domestic hot water storage tank (available as an option) and external backup heater require a dedicated electric circuit for the booster heater. Refer to the use and installation manual of the domestic hot water storage tank. Secure the electric cables in the order shown below.
- Lay the electric cables so that the front panel does not lift up during connections and fix the front panel firmly when finished.
- Connect as shown in the wiring diagrams
- Install the wires and fix the panel firmly so that it fits properly.

## 7.5 Electrical connections

### 7.5.1 Precautions when connecting to the power supply

- Use ring-pressure terminals for connections to the power supply terminal block. If this is not possible for unavoidable reasons, the instructions below should be followed.
- Do not connect wires of different cross-sections to the same power supply terminal block. (Looseness in the power supply wires can cause overheating)
- When connecting electric wires of the same cross-section, proceed as shown in the figure.

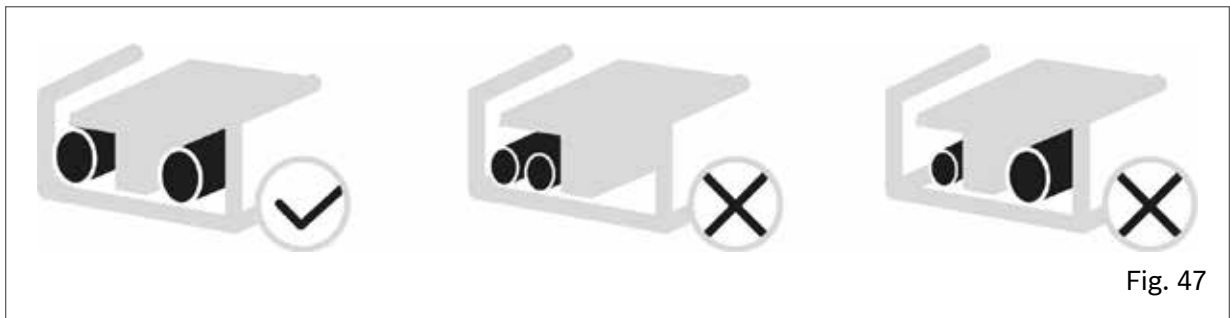

Fig. 47

- Use a suitable screwdriver to tighten the screws on the terminal block. A small-tipped screwdriver could damage the screw head and make tightening impossible.
- Over-tightening the screws on the terminal block could damage them.
- Connect an earth leakage circuit breaker and a fuse or magnetothermic circuit breaker to the power supply line.
- When making connections, use cables with the required specifications, carry out the connection procedures thoroughly, and secure the wires avoiding external pressure on the terminal connectors.

### Wiring diagram of the electrical control system for the cascade system (3N ~)

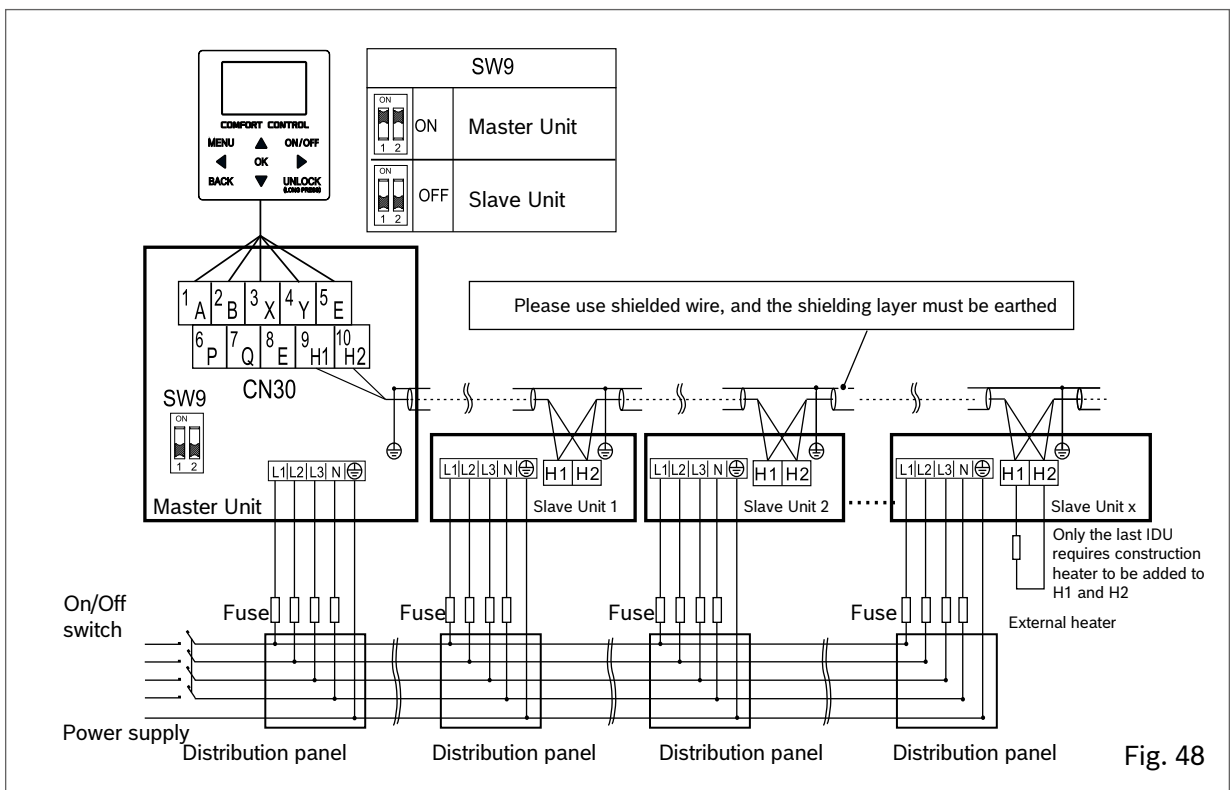
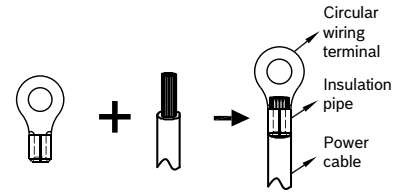

Fig. 48



When connecting to the power supply terminal, use the circular wiring terminal with the insulating sleeve.



Use a power cable that meets the specifications and securely connect it. To prevent the cable from being pulled by an external force, ensure that it is properly secured.

If it is not possible to use the circular wiring terminal with the insulating sleeve, make sure it cannot be used.

Do not connect two power supply cables with different diameters to the same power supply terminal. The wires could overheat due to loose wiring.

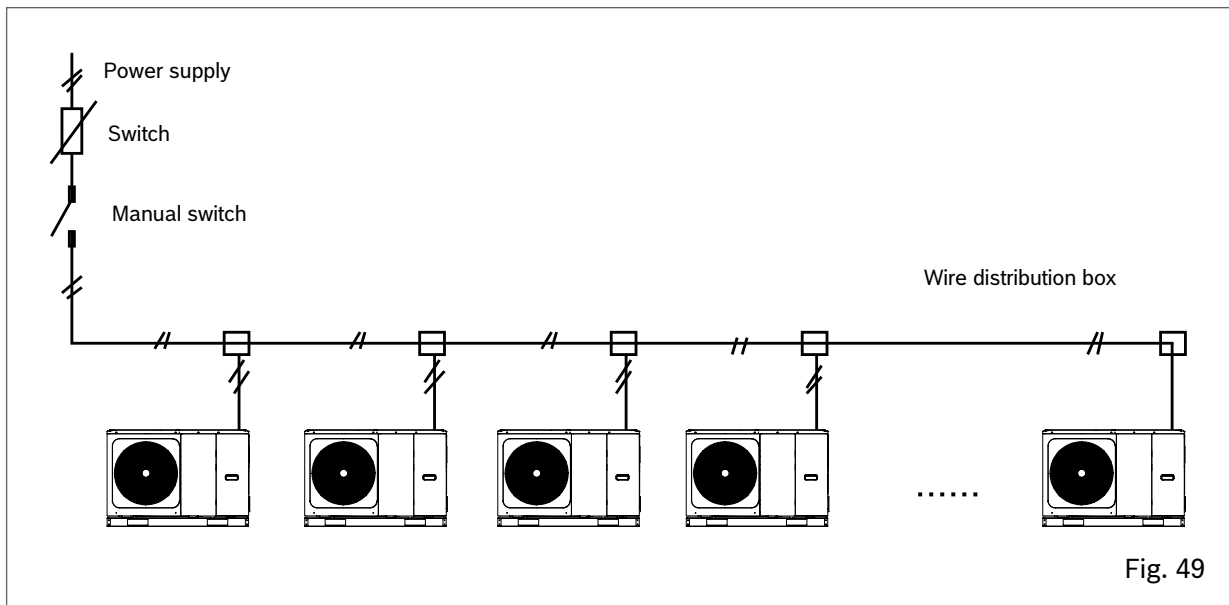
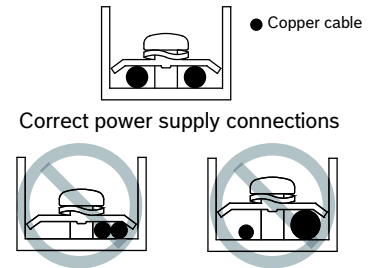

Fig. 49

## 7.5.2 Electrical connection specifications

Compressor compartment and electrical parts: XT1

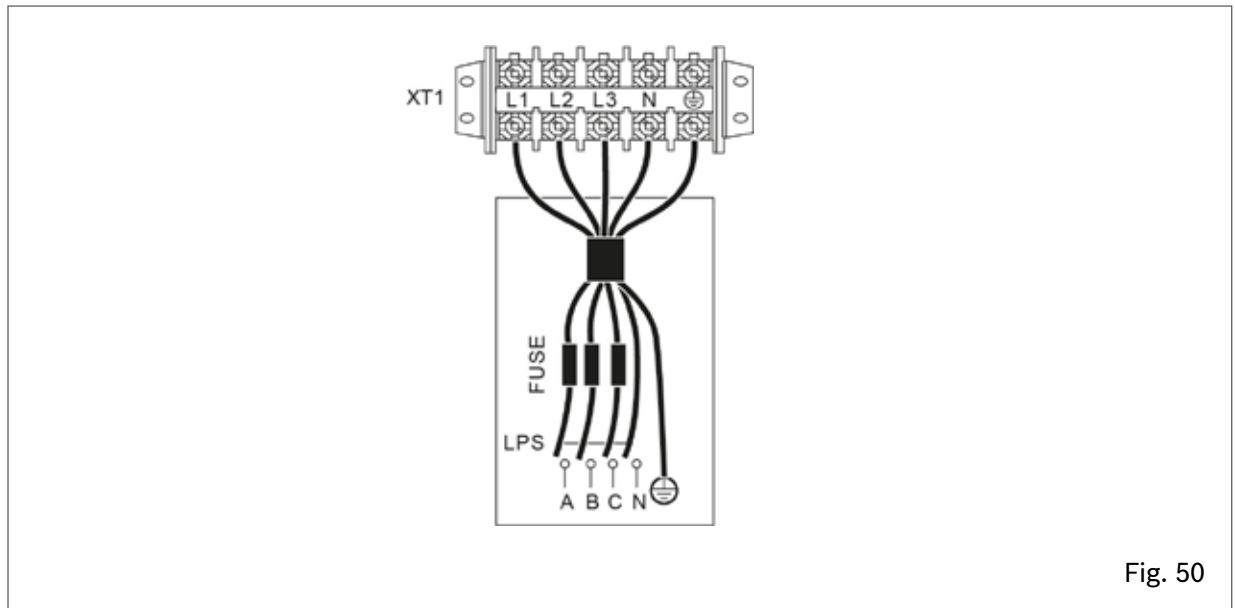

Fig. 50

Size	2.1	3.1	4.1	5.1	6.1	7.1	8.1
FLA (A)	12	14	16	17	25	26	27
Maximum tripping of protections (A)	25	25	25	25	35	35	35
Cable cross-section (mm <sup>2</sup> )	2.5	2.5	4	4	6	6	6

Size	6.1 3~	7.1 3~	8.1 3~	9.1	10.1	12.1	14.1
FLA (A)	10	11	12	21	24.5	27	28.5
Maximum tripping of protections (A)	16	16	16	25	25	32	32
Cable cross-section (mm <sup>2</sup> )	2.5	2.5	2.5	6	6	6	6

### NOTE

The design of the power supply line and its protections is to be provided by the system's electrical designer. The design standards differ depending on the country of installation, the length of the lines, the distance to the protection devices and the quality of the power supply. The minimum cross-section indicated for cables is not necessarily the recommended one.

The values given are maximum values. Refer to the electrical data for the exact values. For the sizing values of the external protections, refer to the rated electrical data (bill, labels).



### WARNING

The earth leakage circuit breaker must be a 30 mA (<0.1 s) fast tripping type.

### Procedure for all connections

- Connect the cable to the appropriate terminals as shown in the diagram.
- Secure the cables with cable ties at the appropriate attachment points to prevent tension.

## 7.5.3 Connection terminal block

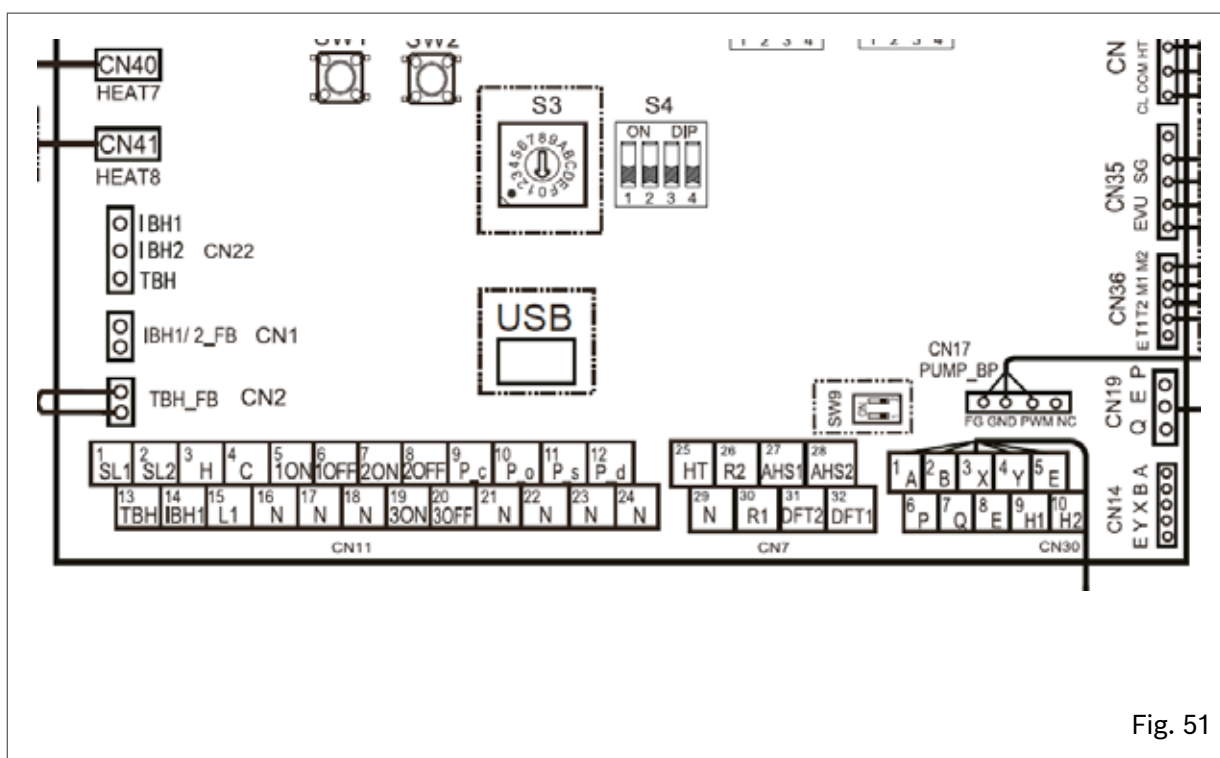

Fig. 51

Ref.	Terminal block CN11		
1	1	SL1	Solar input
	2	SL2	
2	3	H	Room thermostat (220V)
	4	C	
	15	L1	
3	5	1ON	SV1 DHW 3-way valve
	6	1OFF	
	16	N	
4	7	2ON	SV2 3-way zone valve
	8	2OFF	
	17	N	
5	9	P_c	pump P_c (zone2)
	21	N	
6	10	P_o	pump P-o (zone1)
	22	N	
7	11	P_s	solar pump
	23	N	
8	12	P_d	DHW recirculation pump
	24	N	
9	13	TBH	TBH heater
	16	N	
10	14	IBH1	External backup heater
	17	N	
11	17	N	SV3 zone 2 3-way mixing valve
	7	ON	
	19	OFF	

Ref.	Terminal block CN7		
1	26	R2	Unit in operation signal
	30	R1	
	21	DFT2	
2	32	DFT1	Defrosting state or alarm state
	25	HT	
3	29	N	Antifreeze heater for pipes
	27	AHS1	
	28	AHS2	Additional boiler

Ref.	Terminal block CN30		
1	1	A	Wired controller
	2	B	
	3	X	
	4	Y	
	5	E	
2	6	P	Reserved
	7	Q	
3	9	H1	M/S connection for units in cascade
	10	H2	

Other terminal blocks		
CN31	CL	zone thermostat (12V)
	COM	
	HT	
	GND	boiler management signal (0-10V)
	DF	
CN35	EVU	smart grid and photovoltaic inputs
	SG	
CN36	M1	Remote ON/OFF
	M2	

Temperature probes		
CN6	T1	additional heat source
CN24	Tbt1	hydraulic separator
CN16	Tbt2	not used
CN13	T5	DHW boiler
CN15	Tw2	mixed zone supply
CN18	Tsolar	solar thermal

### TYPE 1 control signal

Potential-free contact

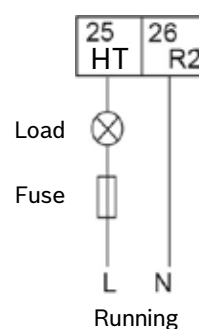

### TYPE 2 control signal

The port provides the signal with a voltage of 220 V

Cable cross-section: 0.75 mm<sup>2</sup>

If the load current is <math>< 0.2\text{A}</math>, the load can be connected directly to the port.

If the load current is  $\geq 0.2\text{A}$ , the AC contactor must be connected for the load

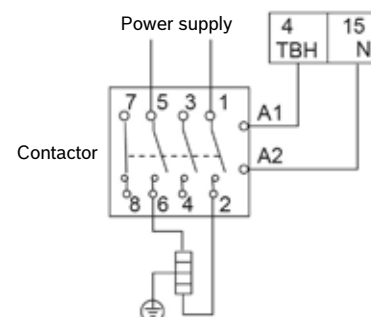

## 7.6 Terminal block connection specifications

### 7.6.1 Terminal block CN11

#### Solar/Solar pump input

Solar pump P<sub>s</sub>  
Control from solar station Enabling  
and configuration on HMI

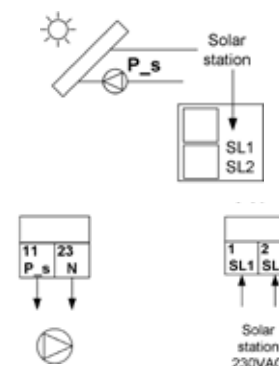

#### Domestic hot water

The electrical connection of the 3-way valve (SV1 - 3-way valve) is different for NC (normally closed) and NO (normally open) valves. Before connection, read the 3-way valve use and installation manual carefully and install the valve as shown in the figure.

Pay attention to the connection terminal numbers.  
Type2 control signal

The connection of the booster heater cable (TBH heater) depends on the type of application.

This connection is only required when a domestic hot water storage tank is installed.

The unit only sends a switch-on/off signal to the booster heater. An additional circuit switch and a dedicated terminal block are required to power the booster heater.

Type2 control signal  
Enabling and configuration on HMI  
Connect probe T5

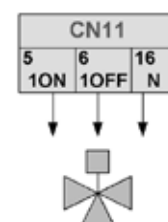
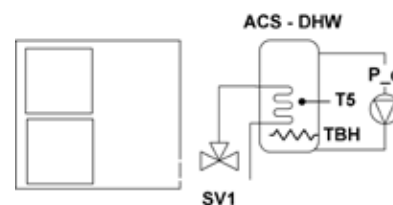

SV1

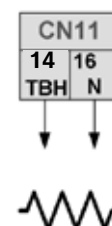

TBH

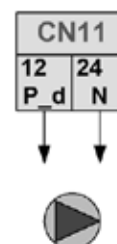

P<sub>d</sub>

DHW circulation pump (P<sub>d</sub>)  
Type2 control signal

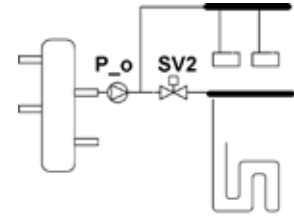
**Double zone system**

External pump - Secondary circuit pump P\_o (zone 1)  
Type2 control signal

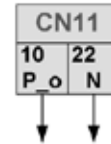

P\_o



SV2 2-way valve  
Enabling and configuration on HMI

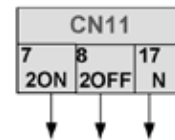

SV2

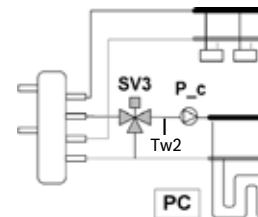
**Double zone mixed system**

Zone 2 mixing pump - Pump P\_c  
P\_c Type2 control signal

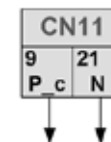

P\_c



3-way valve SV3  
Type2 control signal

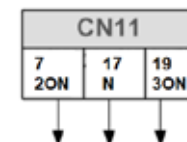

SV3



Room thermostat  
Enabling and configuration on HMI

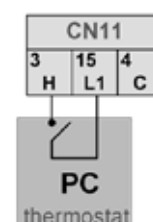

RT

**External backup heater**

Enabling on dip-switch; configuration on HMI

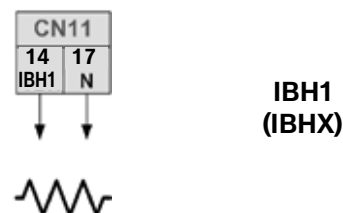

**7.6.2 Terminal block CN7**
**Unit in operation signal**

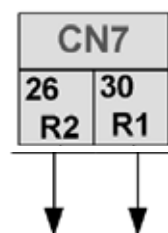
Type2 control signal

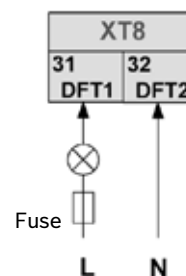

**Defrosting state or alarm state**

Type1 control signal

Enabling and configuration on HMI

**Antifreeze heater for pipes**

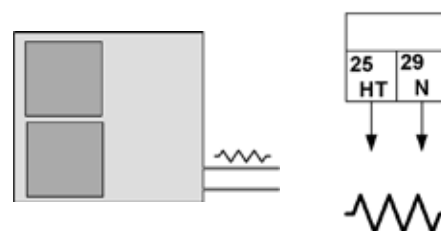
Type2 control signal



**Additional boiler**

The boiler can be controlled in two ways

1. ON-OFF control The setpoint must be set on the boiler keypad
2. ON-OFF consent + 0-10 V signal The setpoint is managed directly by the unit

Enabling on dip-switch; configuration on HMI

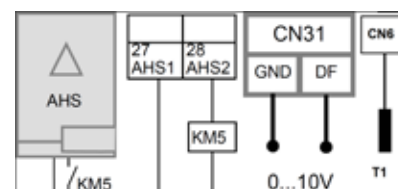
Connect probe T1, boiler input, optional.

**NOTE**

Where HMI enabling is required, refer to the specific chapter.

## 7.7 SMART GRID - Photovoltaic management

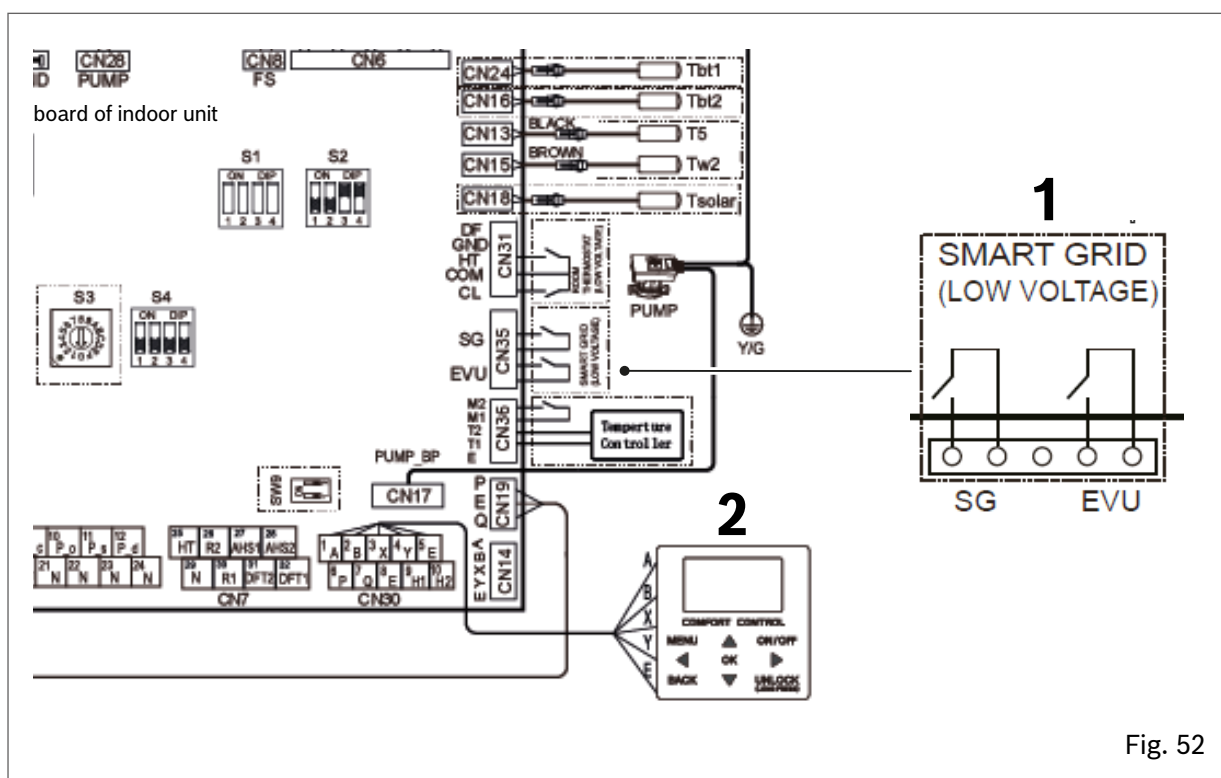
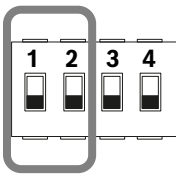
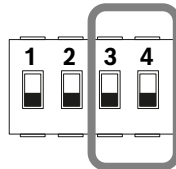
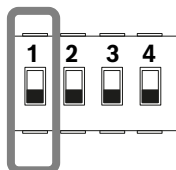
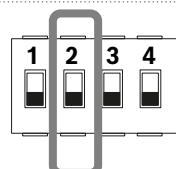
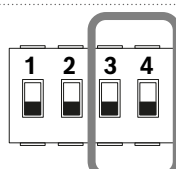
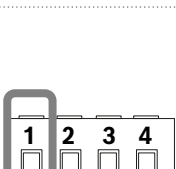
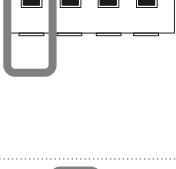
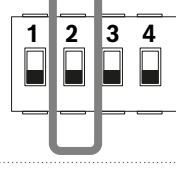
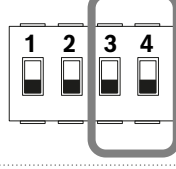

Fig. 52

Description	EVU Photovoltaic signal	SG Smart grid
The unit operates normally	OFF	OFF
The unit is switched off	OFF	ON
The unit is forced into DHW, even if switched off, with setpoint = $T5S + 3^{\circ}\text{C}$	ON	OFF
The unit is forced into DHW with setpoint $T5S = 60^{\circ}\text{C}$ , if switched off; or with setpoint $T5S = 70^{\circ}\text{C}$ .	ON	ON

## 7.8 Dip-switch setting

The dip-switches are located on the main control board of the hydraulic module.

Switch			
S1	1.2		Unit with built-in heater (factory setting): 3kW IBH = 1 Off, 2 Off 6kW IBH = 1 Off, 2 On 9kW IBH = 1 On, 2 On
	3.4		IBH and AHS absent = 3 Off, 4 Off IBH present = 3 On, 4 Off (if with built-in heater: factory setting; if with external heater: setting on site) AHS only Heating = 3 Off, 4 On AHS Heating and DHW = 3 On, 4 On
S2	1		Recirculation every 24H on secondary circuit disabled = 1 On Recirculation every 24H on secondary circuit enabled = 1 Off
	2		TBH absent = On TBH present = Off
	3.4		Reserved
S4	1		If the units are in cascade, they are auto-addressing. If auto-addressing fails: <ul style="list-style-type: none"> <li>• switch off power supply</li> <li>• set 1 = ON and switch on power supply</li> <li>• if the unit is configured as the Master: it deletes the                              addresses present in all Slave units</li> <li>• if the unit is configured as a Slave: it deletes its own address</li> <li>• switch off power supply and set 1 = OFF</li> <li>• switch on power supply: the auto-addressing procedure of                              the Slave units is restarted</li> </ul>
	2		IBH enabled for DHW production = On IBH disabled for DHW production = Off
	3.4		3: ON: the unit is a back-up Master, OFF: the unit is not a back-up Master  4: Reserved
S9	1.2		Configuration of units in cascade Slave = 1 Off, 2 Off Master = 1 On, 2 On

## 7.9 User interface

**NOTE**

Use a shielded wire and connect to earth. This appliance supports the MODBUS RTU communication protocol. Refer to the attached documentation for more information.

The user interface can also be used as a room thermostat. For configuration see Chapter 8. Start-up - initial settings and functions.

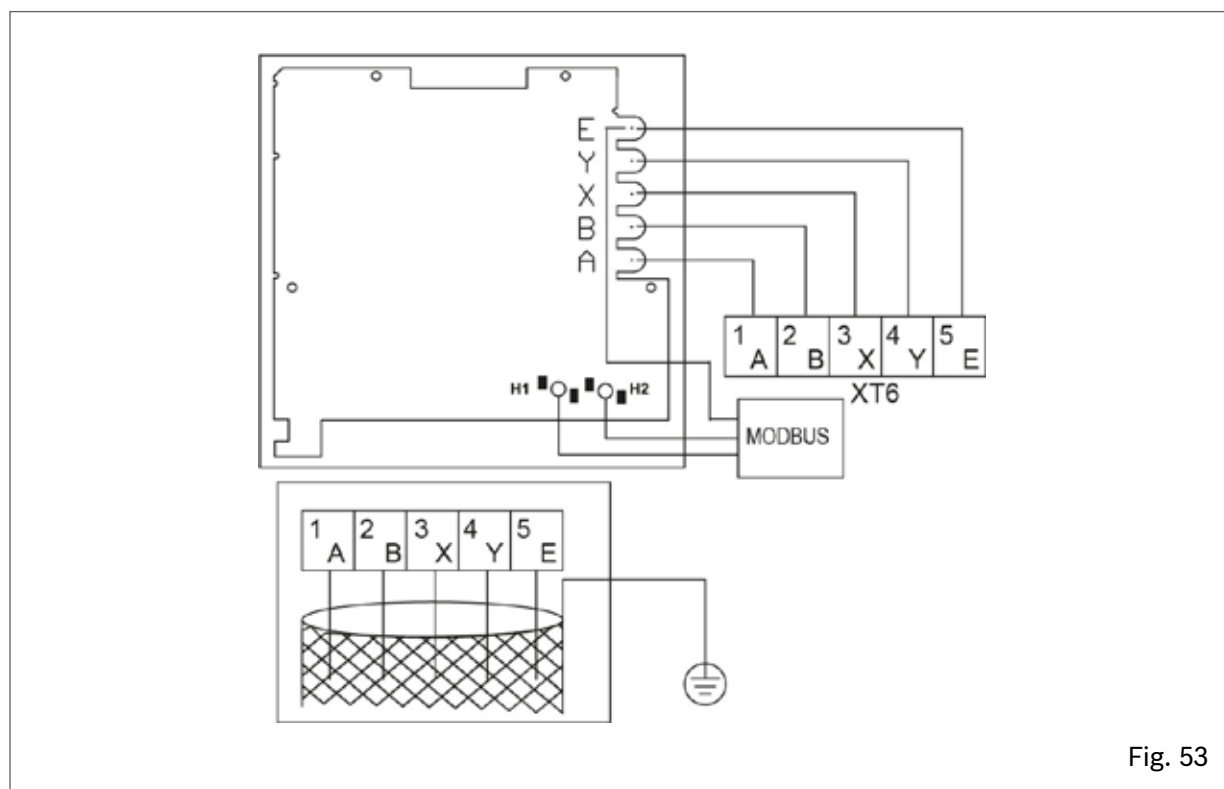

Fig. 53

Component	Type
Cable	5-wire shielded
Cable cross-section (mm <sup>2</sup> )	0.75 ~ 1.25
Maximum cable length (m)	50
Input voltage (A/B)	13.5 VAC

## 7.9.1 User interface installation requirements

Do not install in environments with a strong presence of oil, steam or gaseous sulphides. Failure to do so may result in damage to the product and malfunction.

- Check that all the components listed below are present
- The wired remote control circuit is low voltage. It should not be connected to a normal 220V/380V circuit, nor should it be placed in the same wiring duct as such a circuit.
- The shielded cable must be firmly earthed otherwise transmission problems may occur.
- Do not cut the shielded cable to connect it to an extension lead. Use a terminal block if necessary.
- Do not use a megger to check the insulation of the signal wire when the connection is completed.

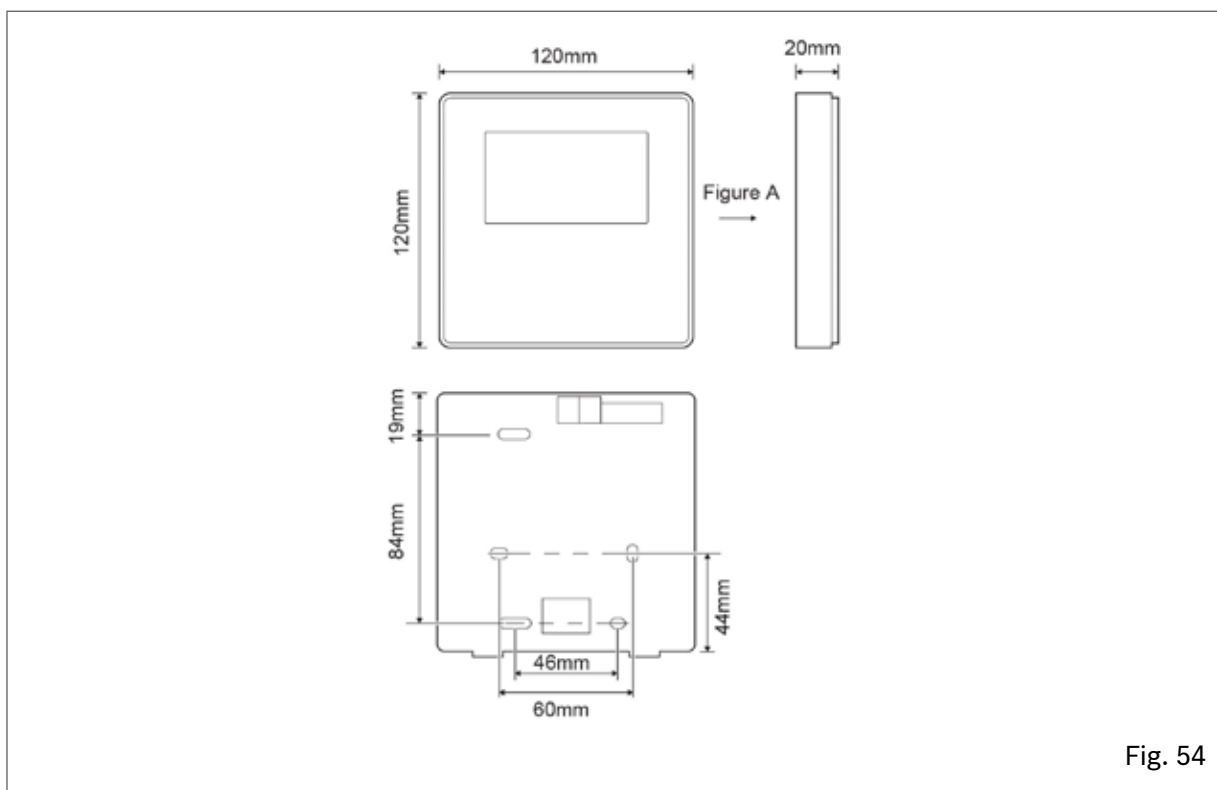
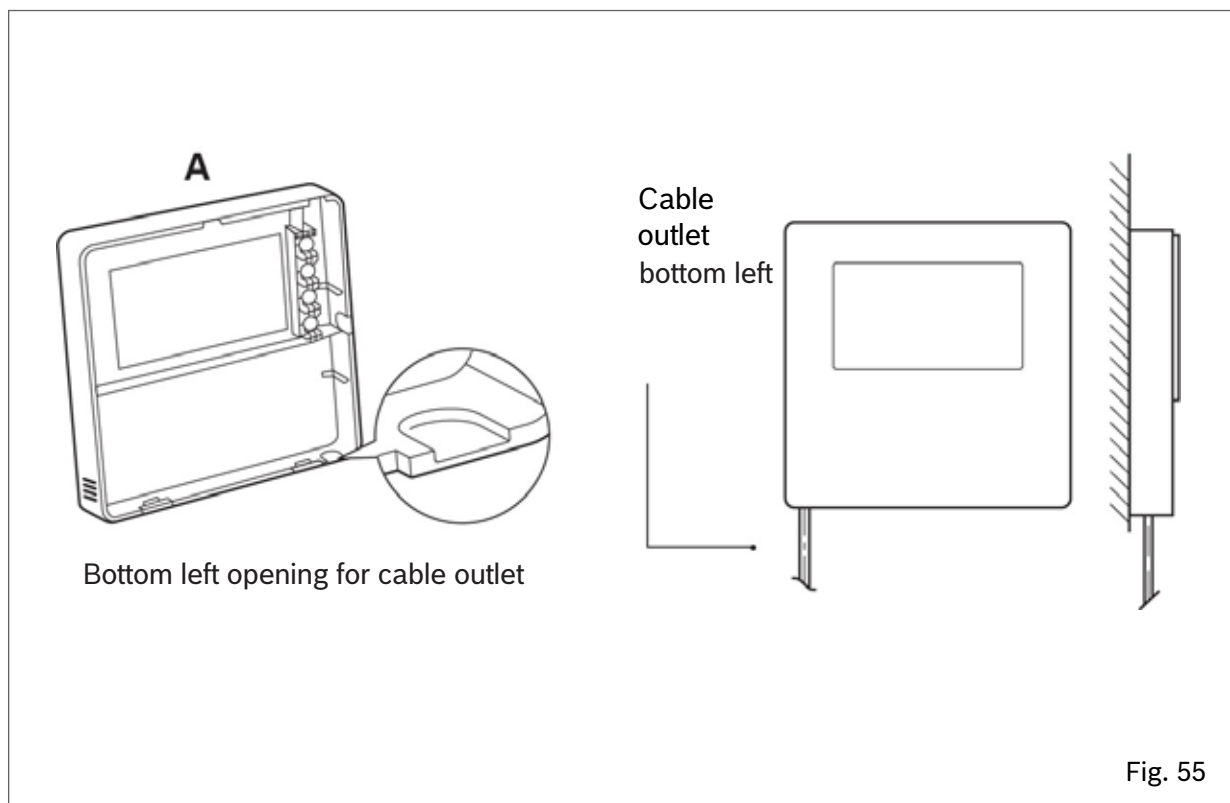

Fig. 54

Num.	Name	Quantity	Notes
1	Wired controller	1	
2	Phillips round head wood screw	3	For wall assembly
3	Phillips round head screw	2	For electrical box assembly
4	Use and installation manual	1	
5	Plastic bolt	2	This accessory is used to install the central control unit inside the control box.
6	Plastic expansion plug	3	For wall assembly

## Installing the back cover

- Insert a flat screwdriver into the indentation at the bottom of the wired controller and pry the back cover off. (Pry off in the correct direction, otherwise the back cover risks being damaged)
- Use three M4X20 screws to install the back cover directly on the wall.
- Use two M4X25 screws to install the back cover on the electrical box 86, then use one M4X20 screw to secure it to the wall.
- Adjust the length of two plastic screw bars supplied as accessories to the standard distance between the screw bar of the electrical box and the wall. Install the screw bar on the wall so that it is flush with the wall.
- Fix the back cover of the wired controller to the wall by inserting the Phillips screws into the screw bar. Check that the back cover of the wired controller is at the same level after installation, then reinstall the wired controller on the back cover.
- Over-tightening the screw will buckle the back cover.



## Wall installation

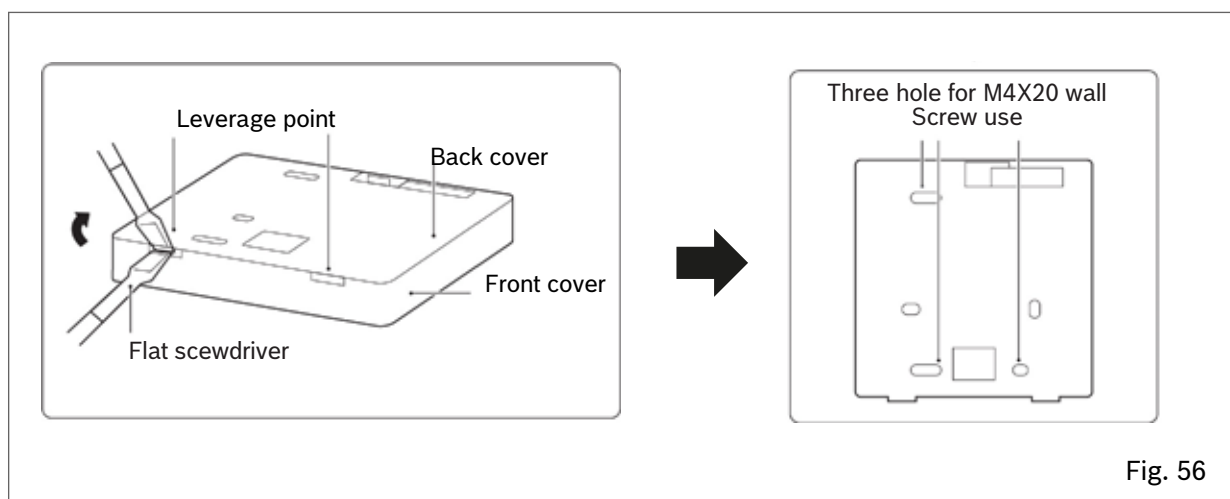



### Installation in electrical box 86

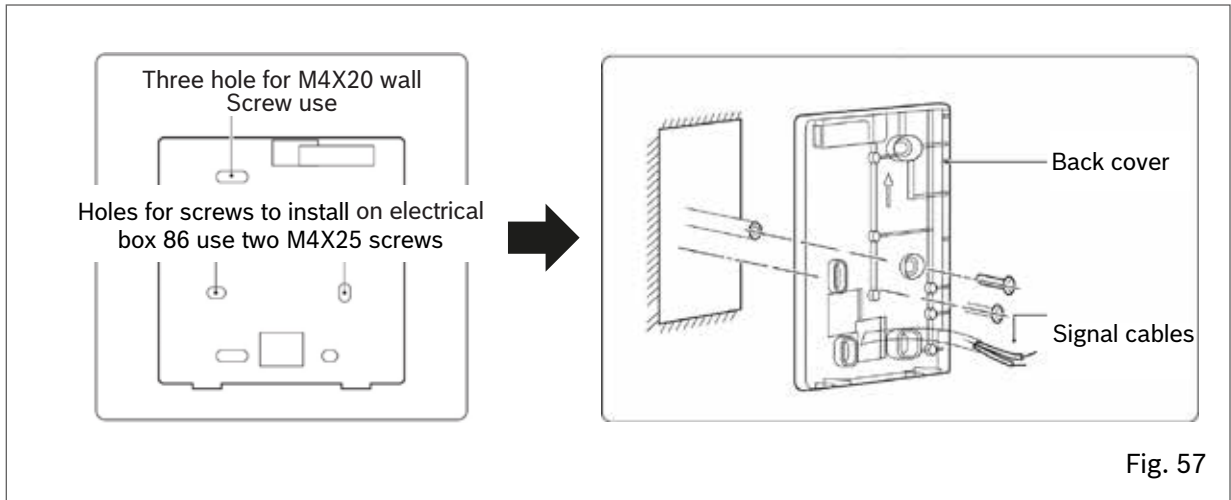

Prevent water from entering the wired controller, use siphons and mastic to seal the wire connectors during installation.

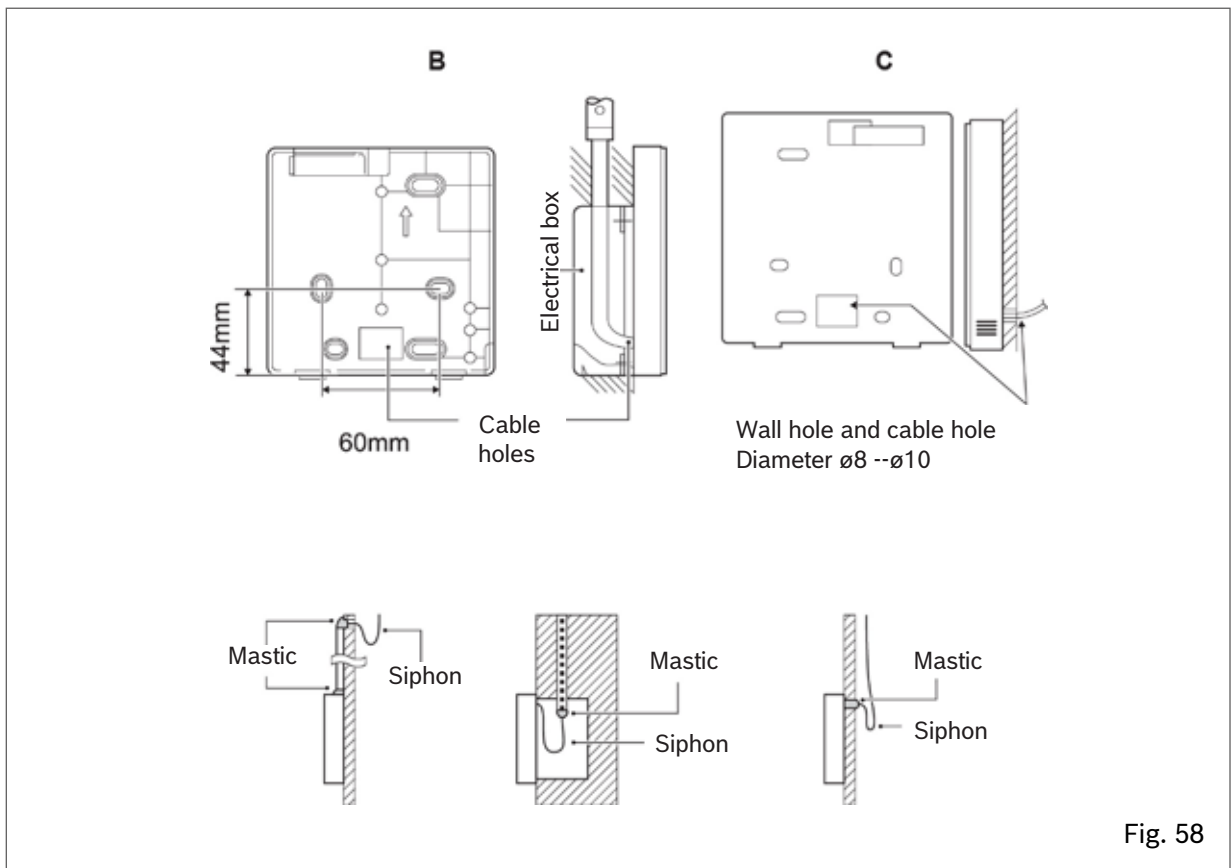

## Installing the front cover

Adjust and then secure the front cover. Do not crush the communication wire during installation.



### WARNING

The sensor must not be exposed to humidity.

Install the back cover correctly and attach the front cover firmly to it (otherwise the front cover may fall off).

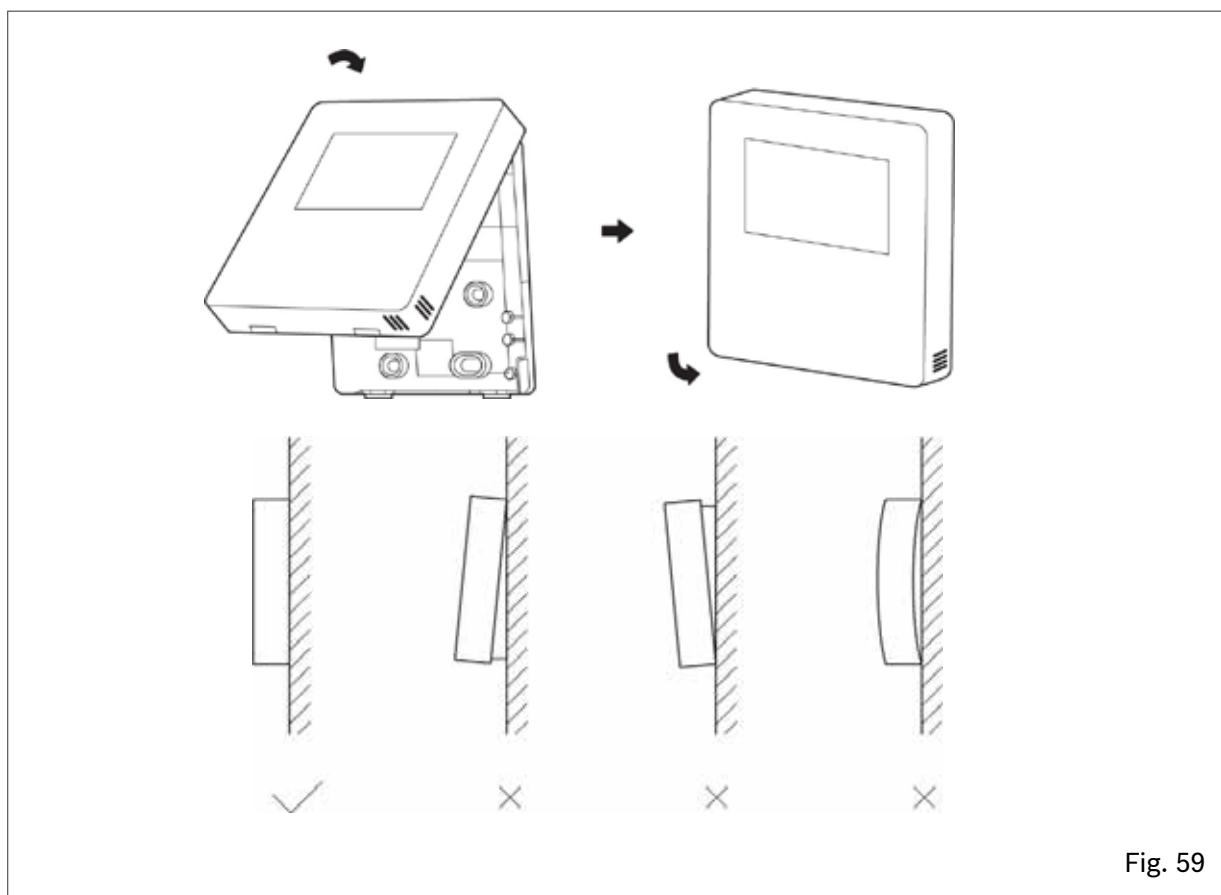

Fig. 59

## 7.10 Zone thermostat

The zone thermostat (to be supplied separately; use the Manufacturer's accessory or equivalent) can be connected in three different ways. The choice of which one to use depends on the type of application.

### Method A

One zone system with zone thermostat managing the unit's ON/OFF and mode change.

User interface setting:  
THERMOSTAT and CAMERA MODE SETTING on YES

HMI setting:  
ROOM THERMOSTAT = MODE SET

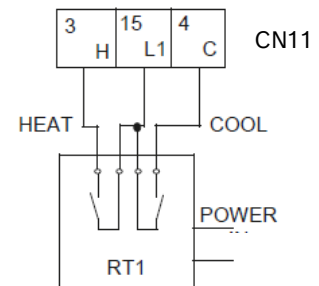

### Method B

One zone system with zone thermostat managing only ON/OFF, user interface managing the unit's mode change.

User interface setting:  
THERMOSTAT and CAMERA MODE SETTING on YES

HMI setting:  
ROOM THERMOSTAT = ONE ZONE

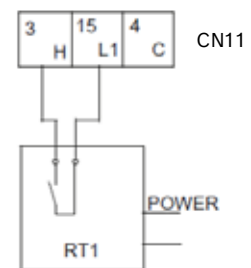

### NOTE

In the presence of a zone thermostat, the HMI must be used to control the water supply temperature. It is not possible to select air temperature control using the HMI air probe.

### Method C

Double zone system with two zone thermostats managing ON/OFF, user interface managing the unit's mode change.

The hydraulic module is connected with two external temperature controllers

- Zone 1 On-Off from input H - L1
- Zone 1 On-Off from input C - L1
- Heat-Cool from user interface

User interface setting:  
DUAL ROOM THERMOSTAT on YES.

HMI setting:  
ROOM THERMOSTAT = DOUBLE ZONE

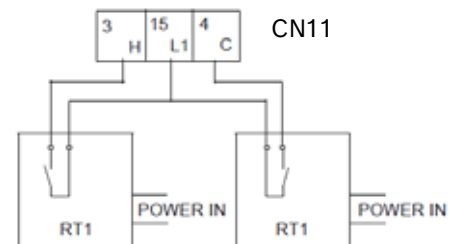

### NOTE

The electrical connection of the thermostat should match the user interface settings. For more information refer to Chapter 8. Start-up - initial settings and functions - room thermostat. The power supply of the unit and that of the room thermostat must be connected to the same neutral line and to the phase line (L2) N (three-phase units only).

## 7.11 Units connected in cascade

---

The cascade function of the system supports a maximum of 6 units.

### 7.11.1 Water connections

---

The water connection should preferably be an inverted return connection for better water balance between the different units.

It is also mandatory to install non-return valves in parallel units to stop the flow through the unit from short circuiting when the circulator is not running.

### 7.11.2 Electrical connections

---

Use shielded wire in M/S cascade connections.

The shielding layer must be earthed.

To ensure successful auto-addressing, all units must be connected to the same power supply and evenly powered.

### 7.11.3 Configuration

---

Only one unit at any one time is configured as the system master.

On a M/S network, only one unit needs to be configured as master; configure SW9 as per Fig 60:

Only the master unit can connect the master controller.

### 7.11.4 Backup master unit

---

It is possible to configure a unit as a backup master, preventing the interruption of certain functions should the master fail. To configure a backup master, dip-switch 3 of the S4 must be set to On. At start-up, the service parameters must be configured independently on both the HMI of the master and the backup master. This can be done by setting the former and copying the parameters to the backup unit via USB. This is the only way to ensure that when the master fails, the other will provide the system with the same pre-loaded functions.

Switching from the Master to the Backup Master will only take place in the event of major system alarms and only the state (On/Off), Mode (Hot/Cold) and setpoint operation parameters are copied. The remaining user setting parameters are not transferred to the system in case of problems. It is therefore advisable to copy that set on the Master to the backup master on a regular basis to prevent loss of the desired settings.



**Wiring diagram of the electrical control system for the cascade system (1N ~)**

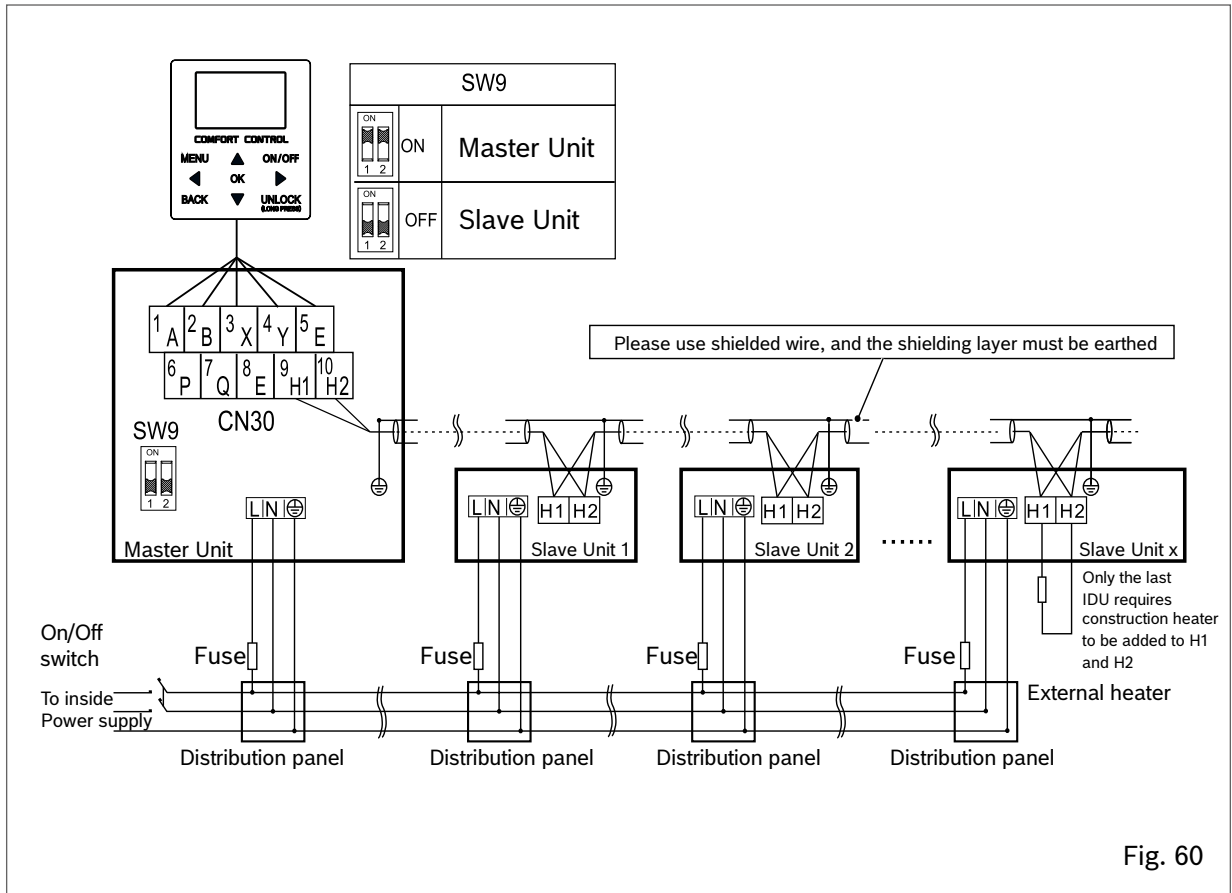

Fig. 60

## 8. Start-up - initial settings and functions

The unit is equipped with a user interface (hereafter also called HMI) to be installed on site and used to manage the functions. The user interface has a built-in temperature probe for possible use as a thermostat. It is designed to have different levels of access depending on the settings to be adjusted: free access functions are designed to be set by the Customer, protected access functions are to be set by a specialized technician.

### NOTE

It is advised against using special characters (e.g. punctuation, spaces, etc.) in the WLAN name. If the router or network password is changed, it may be necessary to delete the units linked to the App and pair them again. The appearance and functions of the App may differ from how they are in this document depending on the release of post-publication updates.



### CAUTION DANGER

The unit must be configured to operate optimally before it can be put into regular service. Configuration entails a Technician adjusting the settings and parameters according to the type of system, climatic conditions, accessories installed and the Customer's usage preferences.

## 8.1 User interface

### 8.1.1 Keypad

The HMI has a touch keypad with the following buttons:

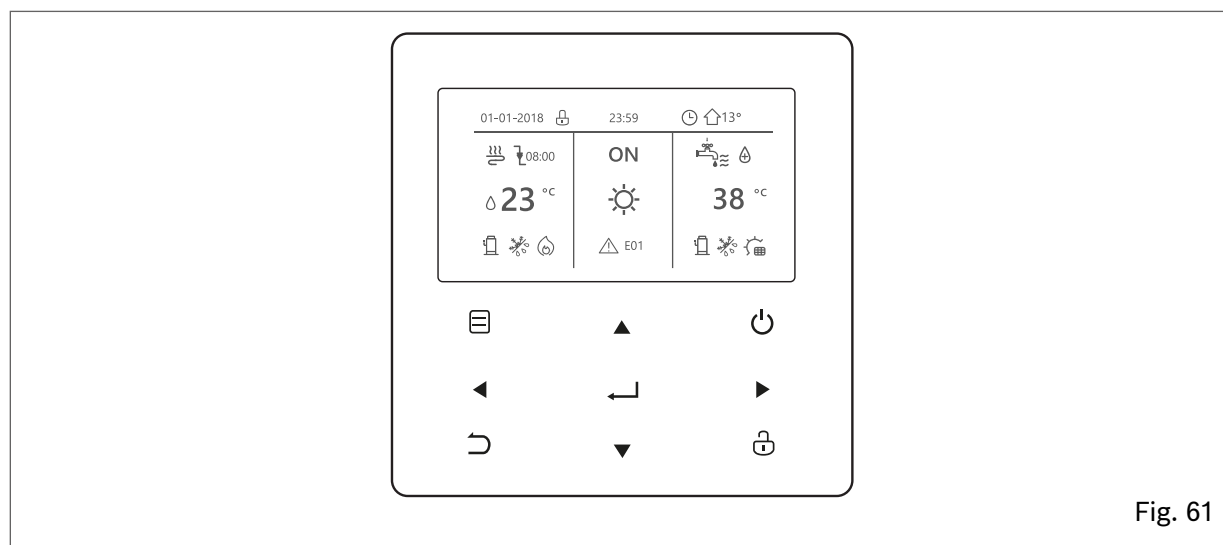







Fig. 61

Buttons		Function
	MENU	To open the various menus from the HOME page
	ON/OFF	To switch on/off the heating/cooling modes or DHW mode To switch on/off the functions in the menu structure
	UNLOCK	Press the button for 3 seconds to Unlock/Lock the keypad To unlock/lock certain functions such as "DHW temperature control"
	OK	To enter a submenu To confirm entered values
	LEFT - RIGHT DOWN - UP	To move the cursor on the screen/navigate in the menu structure/ adjust parameter settings
	BACK	To return to the previous level or page Long button press to return straight to the home page

### 8.1.2 Display and icons

The HMI display has the following icons:

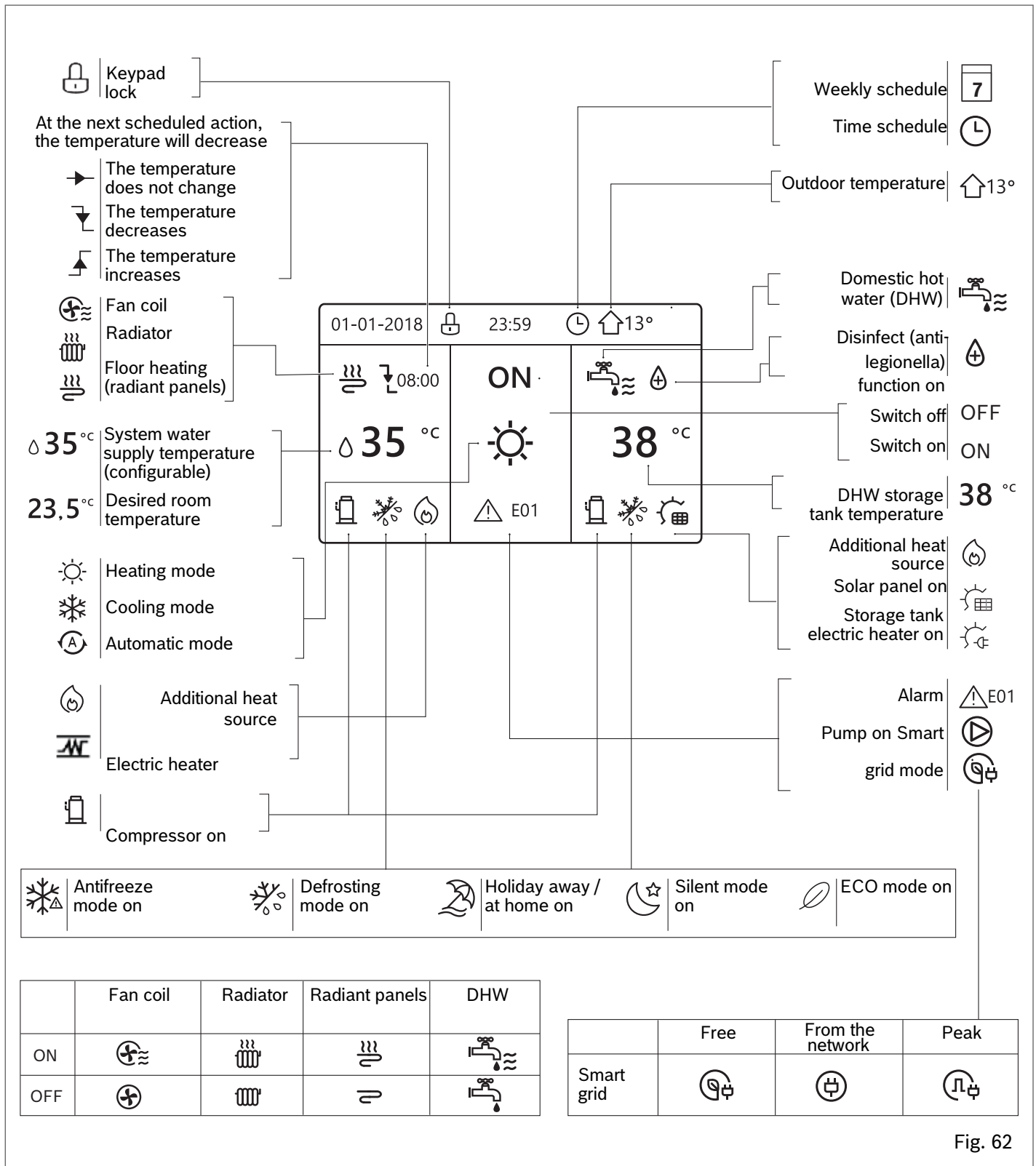

Fig. 62

NOTE  
Temperature values are given in °C

### 8.1.3 First switch-on and language selection

When the unit is switched on for the first time, the HMI will initialise the system and display the percentage of completion (1%~99%): the HMI cannot be used during this process. The HMI then prompts you to select the system language from those available:

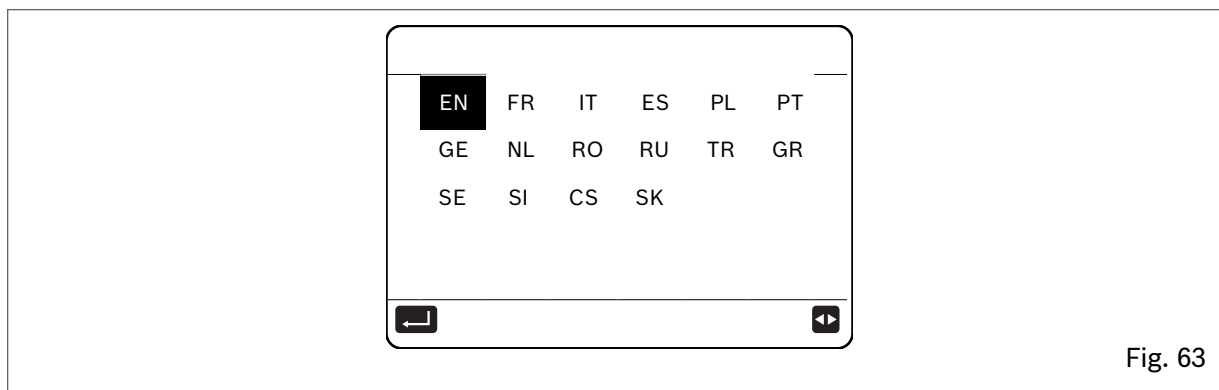



Fig. 63

You can navigate through the options with the arrow buttons on the keypad and confirm with 

#### NOTE

If no language is confirmed within 60 seconds, the HMI will confirm the selected language when the time expires.

Once the selection has been made, the HMI will display the home page and it can be used normally.

### 8.1.4 Menu structure

The main menu is accessible from the home page by pressing  and contains the following sections:

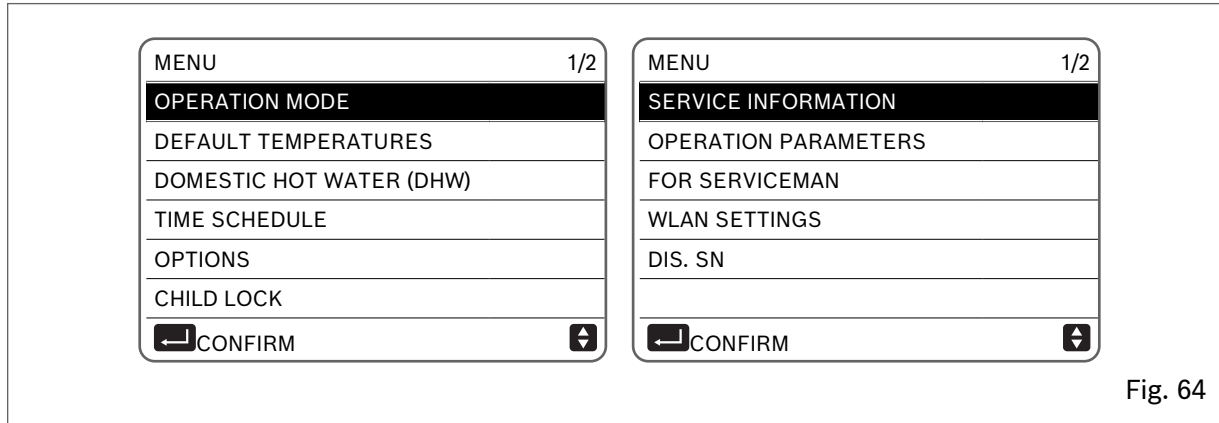



Fig. 64

Each of these categories allows specific unit functions and options to be set.

You can scroll through the sections with the arrows on the keypad, to confirm press .



### 8.1.5 Functions reserved for the Technician

The “FOR SERVICEMAN” section contains the settings that can be adjusted by the Technician when starting the unit for the first time.

Once the appropriate section has been selected from the main menu, an access password will be request-ed:

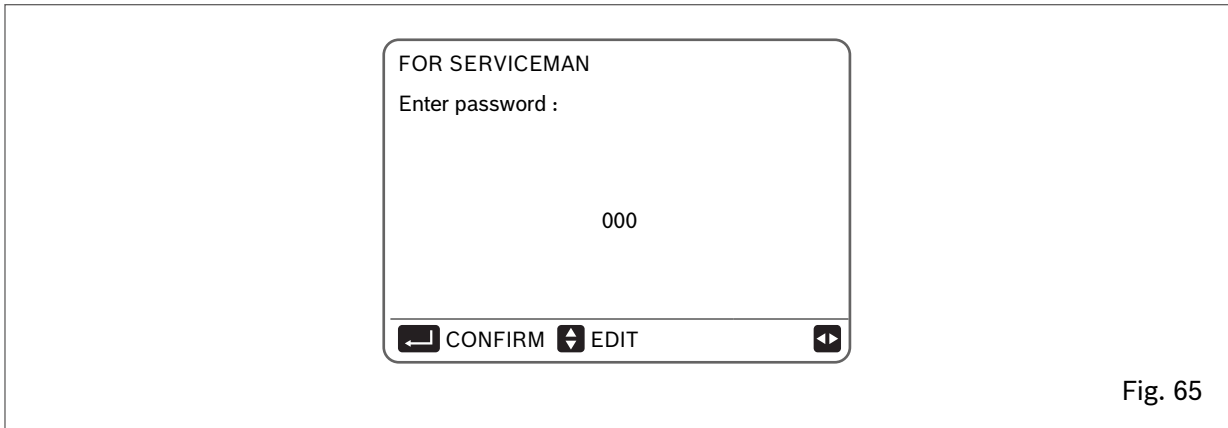

Fig. 65

The password to be entered is **234**: choose the characters with and edit the values with . The

“FOR SERVICEMAN” section is divided into the following sub-categories:

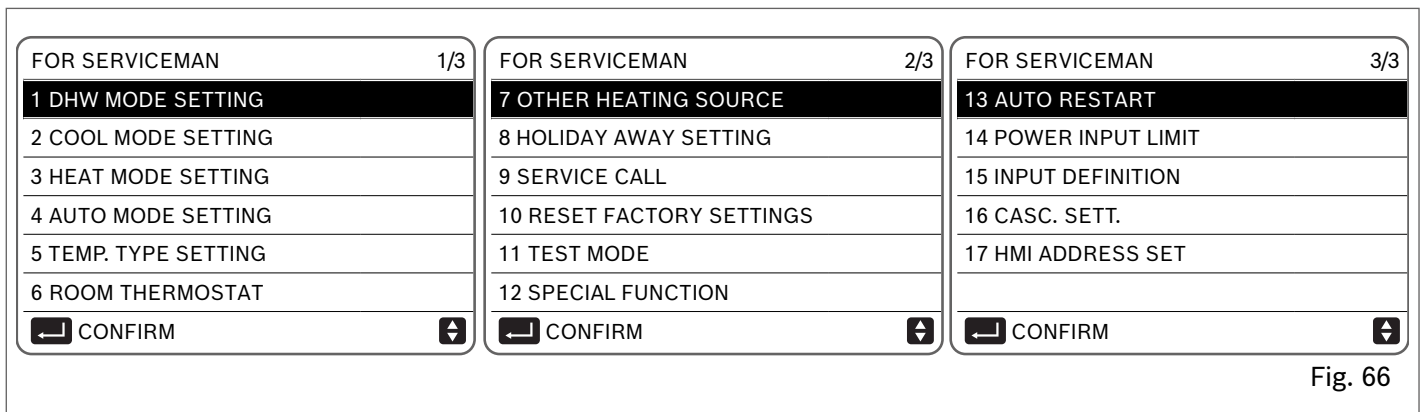

Fig. 66

#### NOTE

See chapter “8.2 Initial unit setting (requires a specialised Technician)” on page 78.

When you have finished editing the desired parameters, press and this page will appear:

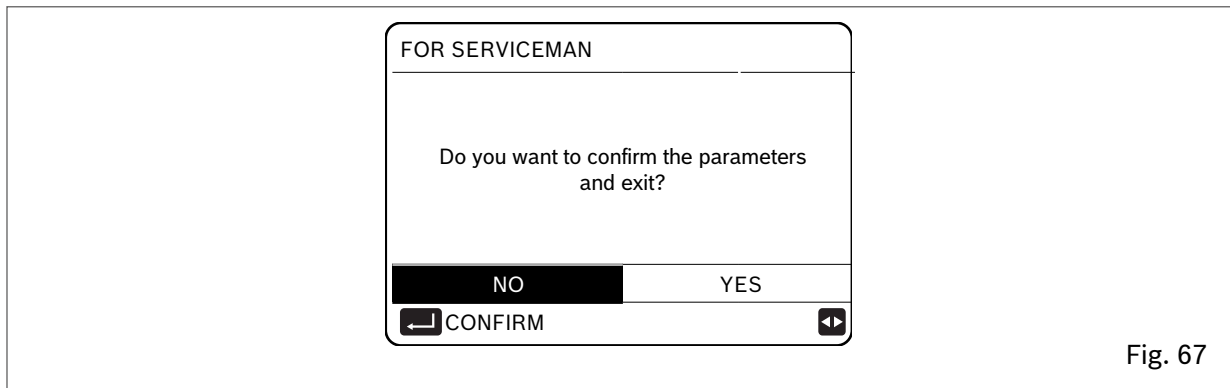

Fig. 67

Select “YES” and confirm with to save the settings and exit. After exiting, the unit will shut down.

## 8.1.6 Terminology used

The terms related to this unit are shown in the table below

Parameter	Description
AHS	Backup boiler
IBH	Backup electric heater
P_i	Unit pump or Zone 1 pump (for double zone systems)
P_o	Secondary circuit pump (or Zone 1 pump for double zone systems)
P_c	Zone 2 pump (for double zone systems)
P_d	DHW recirculation pump
P_s	Solar circuit pump
Pe	Evaporation pressure in Cooling mode or condensation pressure in Heating mode
SV1	3-way circuit/DHW diverter valve
SV2	3-way diverter valve for direct double zone systems
SV3	3-way mixing valve for mixed circuit
T1	Water supply temperature from additional heating source (with IBH heater or AHS boiler)
T2	Refrigerant temperature entering the user side exchanger (plate heat exchanger) in Cooling mode (or leaving in Heating mode)
T3	Refrigerant temperature leaving the source exchanger (coil) in Cooling mode (or entering in Heating mode)
T4	Outdoor air temperature
T5	DHW tank temperature
T1S	Water supply temperature setpoint
Ta	Room air temperature, detected by the probe in the HMI
Tbt1	Temperature of the upper part of the inertial storage tank
TBH	Backup electric heater for DHW (Domestic Hot Water) storage tank
Th	Compressor suction refrigerant temperature
Tp	Compressor discharge refrigerant temperature
Tsolar	Water temperature in the solar thermal circuit
Tw2	Water supply temperature for the mixed zone (for double zone systems)
TWin	Unit water return temperature
TWout	Unit water supply temperature

## 8.2 Initial unit setting (requires a specialised Technician)

### 8.2.1 DHW (Domestic Hot Water) mode settings

MENU > FOR SERVICEMAN > 1. DHW MODE SETTING

1 DHW MODE SETTING	1/5
1.1 DHW MODE	YES
1.2 DISINFECT	YES
1.3 DHW PRIORITY	YES
1.4 PUMP D	YES
1.5 DHW PRIORITY TIME SET	NONE
↕ ADJUST	↕

Fig. 68

#### 1.1 DHW MODE (standard: YES - settable: YES/NO)

Enables/disables Domestic Hot Water mode

#### 1.2 DISINFECT (standard: YES - settable: YES/NO)

Enables/disables the anti-legionella cycle

#### 1.3 DHW PRIORITY (standard: YES - settable: YES/NO)

Defines whether DHW mode has priority over operation in Heating/Cooling mode

#### 1.4 PUMP\_D (standard: NO - settable: YES/NO)

Enables DHW recirculation management by the unit

#### 1.5 DHW PRIORITY TIME SET (standard: NO - settable: YES/NO)

- Enables two controls and their respective parameters:
- in the presence of a DHW request, it defines a maximum operating time in Heating/Cooling mode before switching to DHW (managed with parameter  $t_{\text{DHWHP\_RESTRICT}}$ );
- in the presence of a system request, it defines a maximum operating time in DHW before switching to Heating/Cooling mode (managed with parameter  $t_{\text{DHWHP\_MAX}}$ ).

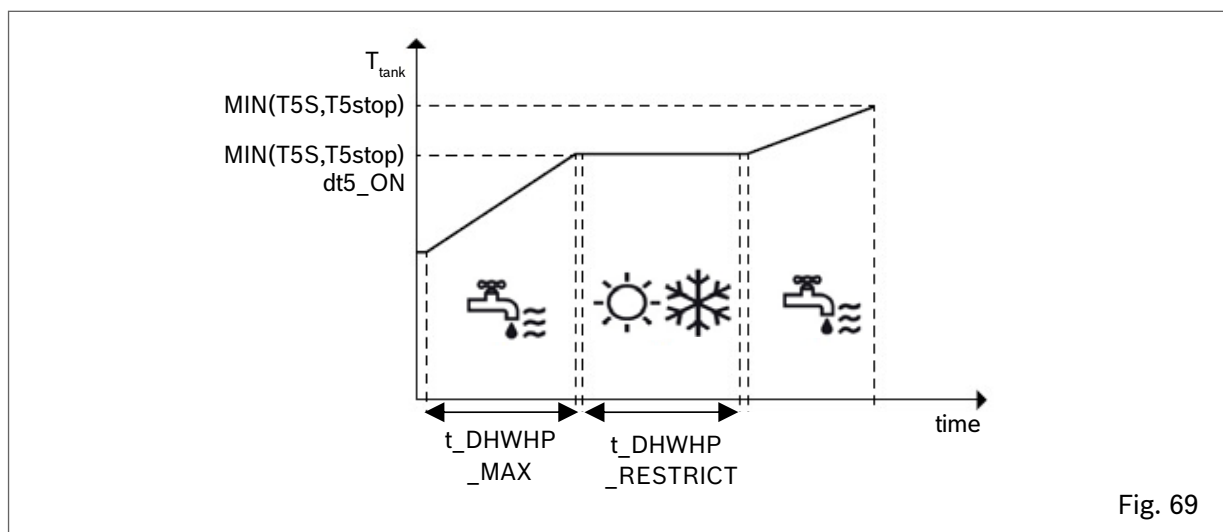

Fig. 69



1 DHW MODE SETTING	2/5
1.6 dT5_ON	5°C
1.7 dT1S5	10°C
1.8 T4DHWMAX	43°C
1.9 T4DHWMIN	-10°C
1.10 t_INTERVAL_DHW	5 MIN
ADJUST	

Fig. 70

### 1.6 dT5\_ON (standard: 10 - settable: 1/30)

Controls activation of the DHW request, defining the temperature range between DHW setpoint (T5S) and DHW storage tank temperature (T5) beyond which the heat pump is to be activated.

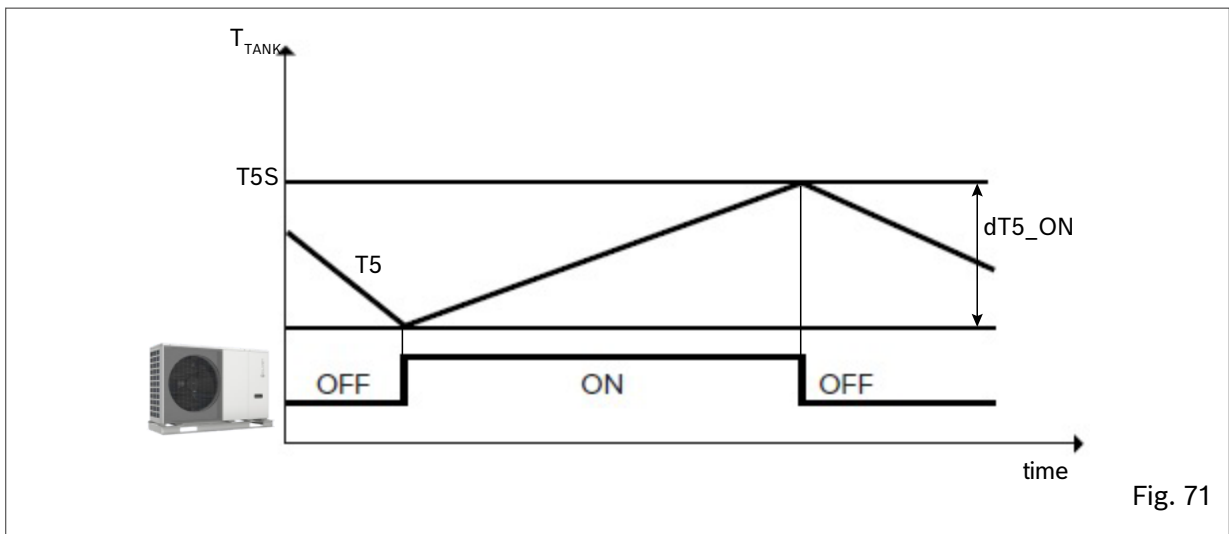

Fig. 71

DHW is requested when  $T5S - T5 \geq dT5\_ON$

#### NOTE

A DHW request ends when  $T5 \geq T5S$  or when T5 reaches the maximum temperature for DHW in the heat pump T5stop, which is parameterised according to the outdoor temperature T4.

Size	T4 [°C]						
	65 to 40	40 to 35	35 to 30	30 to 25	25 to 20	20 to 15	15 to 10
2.1 to 8.1	45	48	50	55		56	57
9.1 to 14.1			48	50		53	55

Size	T4 [°C]						
	10 to 5	5 to 0	0 to -5	-5 to -10	-10 to -15	-15 to -20	<-20
2.1 to 8.1	56	55	52	50		40	35
9.1 to 14.1	55	53	50	48	45		



#### CAUTION

If there is a further demand for DHW beyond T5stop, the unit can activate the TBH boiler heater until set-point T5S is reached.

### 1.7 dT1S5 (standard: 10 - settable: 5/40)

Defines the range between the water supply temperature (Twout) and the DHW storage tank temperature (T5). The heat pump in DHW mode will deliver water at  $Twout = T5 + dT1S5$ .



### NOTE

If the DHW set point (T5S) > 55°C, change the parameter according to the formula  $dT1S5 = 65 - T5S$ . Setting dT1S5 higher than this criterium makes the unit work faster and less efficient in charging cycles but also means that the unit will go into normal protection before reaching the set point with subsequent restart and loss of the benefits of the faster ramp.

### 1.8 T4DHWMAX (standard: 43 - settable: 35/43)

Defines the maximum outdoor air temperature for which the unit can operate in DHW with heat pump

### 1.9 T4DHWMIN (standard: -10 - settable: -25/30)

Defines the minimum outdoor air temperature for which the unit can operate in DHW with heat pump

### NOTE

Below T4DHWMIN, if within the operating range, the unit can produce DHW with the DHW storage tank heater (TBH).

### 1.10 t\_INTERVAL\_DHW (standard: 5 - not adjustable)

Defines the minimum minutes between compressor shutdown and subsequent restart in DHW mode. Activation logic of heat pump and TBH storage tank heater in DHW mode.

### NOTE

The activation logics of the DHW storage tank heater (TBH) are automatically managed by the unit.

1 DHW MODE SETTING	3/5
1.11 dT5_TBH_OFF	5°C
1.12 T4_TBH_ON	5°C
1.13 t_TBH_DELAY	30 min
1.14 T5S_DISINFECT	65°C
1.15 t_DI_HIGHTEMP.	15 MIN
↕ ADJUST	↕

Fig. 72

### 1.11 dT5\_TBH\_OFF (standard: 5 - settable: 0/10)

Defines how many degrees above the DHW setpoint (T5S) the storage tank heater (TBH) must be brought to. When TBH is activated, the DHW storage tank will be brought to temperature  $T5S + dT5\_TBH\_OFF$ .

### NOTE

When the temperature of the DHW storage tank (T5) reaches T5stop, the heat pump stops and the DHW storage tank heater (TBH) can continue to operate. The TBH heater is switched off when the DHW storage tank temperature is  $T5 > T5S + dT5\_TBH\_OFF$  or  $T5 > 65°C$ . Any protection of the heating element built into the storage tank should be set to  $T5S+dT5\_TBH\_OFF$ .

### 1.12 T4\_TBH\_ON (standard: 5 - settable: -5/50)

Defines the maximum outdoor air temperature at which the TBH heater can be activated.

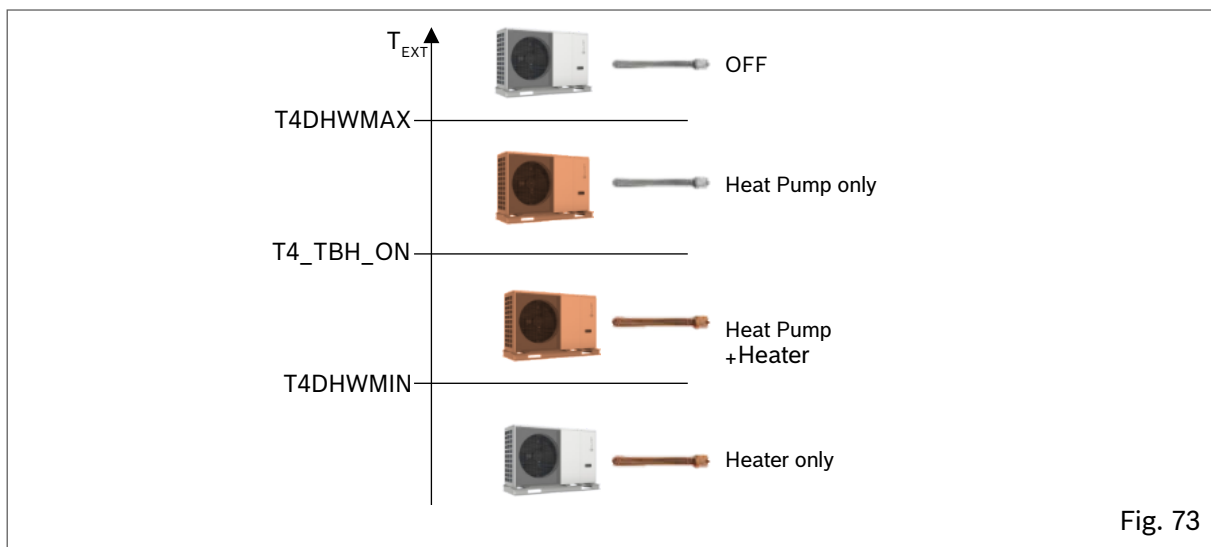

Fig. 73

### 1.13 t\_TBH\_DELAY (standard: 30 - settable: 0/240)

Defines the minimum minutes of compressor operation beyond which, if the unit fails to bring the DHW storage tank to the setpoint, the TBH heater can be activated.

Activation logic of the DISINFECT (anti-legionella) function.

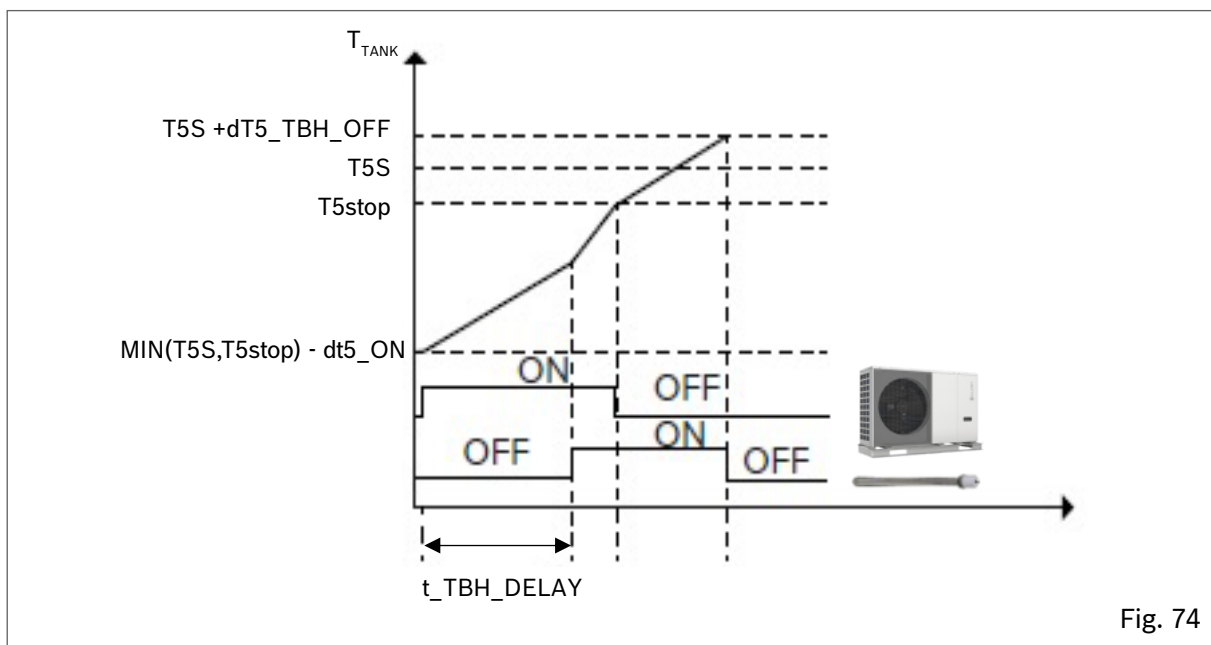

Fig. 74

### 1.14 T5S\_DISINFECT (standard: 65 - settable: 60/70)

Defines the temperature to which the unit brings the DHW storage tank in the DISINFECT (anti-legionella) function.

### 1.15 t\_DI\_HIGHTEMP (standard: 15 - settable: 5/60)

Defines the minutes for which the unit should keep the DHW tank at temperature T5S\_DISINFECT in the DISINFECT (anti-legionella) function.

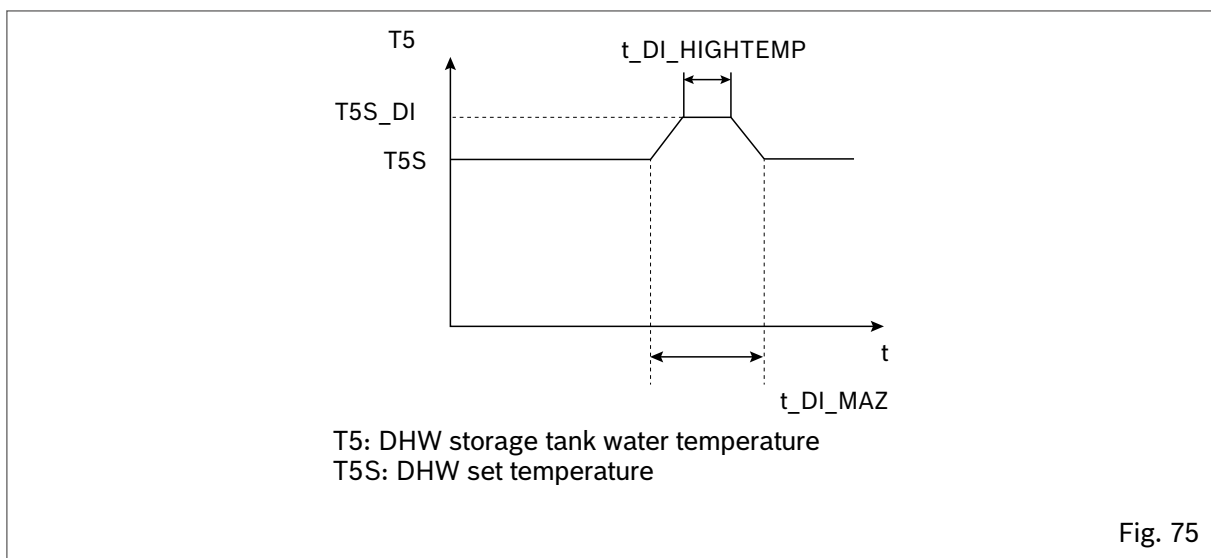

1 DHW MODE SETTING	4/5
1.16 t_DI_MAX	210 MIN
1.17 t_DHWHP_RESTRICT	30 MIN
1.18 t_DHWHP_MAX	120 MIN
1.19 PUMP_D TIMER	YES
1.20 PUMP_D DISINFECT TIME	5 MIN
⬇️ ADJUST	⬆️

Fig. 76

### 1.16 t\_DI\_MAX (standard: 210 - settable: 90/300)

Defines the maximum minutes for which the unit can keep the DISINFECT (anti-legionella) function on.

### 1.17 t\_DHWHP\_RESTRICT (standard: 30 - settable: 10/600)

in the presence of a DHW request, it defines the maximum operating minutes of the heat pump in Heating/Cooling mode before switching to DHW mode. Clearly, the parameter only applies if priority has been given to the system.

#### NOTE

During operation in Heating/Cooling mode, the heat pump switches to DHW mode once the system set-point has been reached or after the minutes in t\_DHWHP\_RESTRICT have elapsed.

### 1.18 t\_DHWHP\_MAX (standard: 90 - settable: 10/600)

in the presence of a Heating/Cooling request, it defines the maximum operating minutes in DHW mode before switching to Heating/Cooling mode. Clearly, the parameter only applies if priority has been given to DHW.

#### NOTE

during operation in DHW mode, the heat pump switches to Heating/Cooling mode once the DHW setpoint has been reached or after the minutes in t\_DHWHP\_MAX have elapsed.

### 1.19 PUMP\_D TIMER (standard: YES - settable: NO/YES)

Enables hourly scheduling of the DHW circulation pump. The pump schedule can be set by the user.

#### NOTE

The recirculation pump requires a dedicated power supply

### 1.20 PUMP\_D RUNNING TIME (standard: 5 - settable: 5/120)

Defines the operating minutes of the circulation pump when it is started.

1 DHW MODE SETTING	5/5
1.21 PUMP_D DISINFECT RUN	NONE
1.22 ACS FUNCTION	NONE
1.23 t_ANTILOCK	5 MIN
 ADJUST	

Fig. 77

### 1.21 PUMP\_D DISINFECT RUN (standard: YES - settable: NO/YES)

Enables activation of the recirculation pump even during the anti-legionella cycle. Activation of the function is recommended. It becomes mandatory if T5 is located below the additional heater (TBH).

### 1.22 ACS FUNCTION (standard: NO - settable: YES/NO)

Reserved parameter, do not change.

### 1.23 t\_ANTILOCK (standard: 5 - settable: 0/60)

Enables a safety opening cycle of all system valves (SV1, SV2, SV3), defining their opening minutes if they remain closed for more than 24 hours.

## 8.2.2 Cooling mode settings

### MENU > FOR SERVICEMAN > 2. COOLING MODE

#### 2.1 COOL MODE (standard: YES - settable: YES/NO)

Enables/disables Cooling mode.

#### 2.2 t\_T4\_FRESH\_C (standard: 0.5 - settable: 0.5/6)

Sets the time when the unit updates the climate curve, adjusting it according to the outdoor air temperature.

#### 2.3 T4CMAX (standard: 52 - settable: 35/52)

Defines the maximum outdoor air temperature for which the unit can operate in Cooling mode. This value should clearly be changed if the unit is used for process cooling.

#### 2.4 T4CMIN (standard: 10 - settable: -5/25)

Defines the minimum outdoor air temperature for which the unit can operate in Cooling mode. This value should clearly be changed if the unit is used for process cooling.

#### 2.5 dT1SC (standard: 5 - settable: 2/10)

Defines the range between the water supply temperature (T1) and the setpoint (T1S) within which the unit starts to operate in Cooling mode. The heat pump starts when  $T1 \geq T1S + dT1SC$  and stops when  $T1 \leq T1S$ .

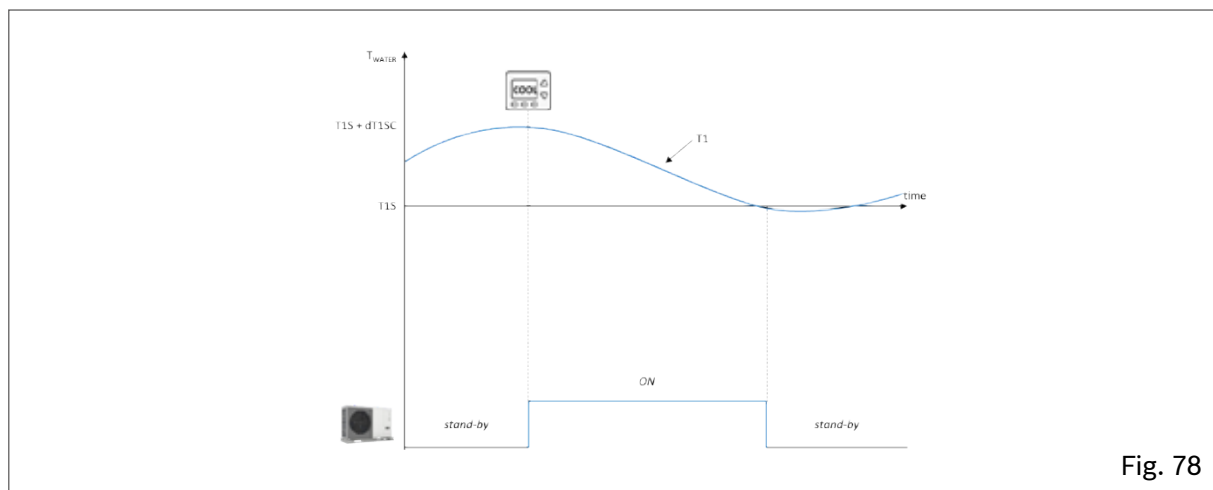

Fig. 78

This value is strongly related to the minimum permissible water content of the circuit. A narrower control band can be accepted with a high water volume.

**2.6 dTSC (standard: 2 - settable: 1/10)**

Defines the range between the room air temperature ( $T_a$ ) and the setpoint ( $T_S$ ) within which the unit starts to operate in Cooling mode. The heat pump starts when  $T_a \geq T_S + dTSC$  and stops when  $T_a \leq T_S$ .

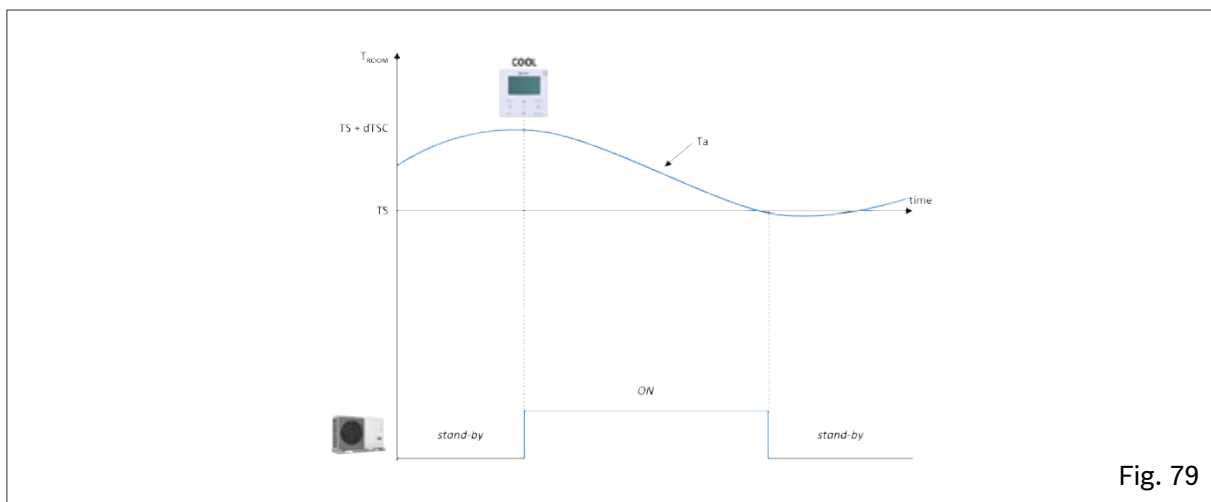

Fig. 79

**NOTE**

The parameter is only used if the unit's Cooling mode control is on room air temperature.

**2.7 t\_INTERVAL\_COOL (standard: 5 - not adjustable)**

Defines the minimum minutes between compressor shutdown and subsequent restart in Cooling mode. Among the climate curves that can be set for Cooling mode, a customisable one can be set with logic as shown in the graph.

**2.8 T1SetC1 (standard: 10 - settable: 5/25)**

Sets the maximum water supply setpoint for the customisable climate curve in Cooling mode.

**2.9 T1SetC2 (standard: 16 - settable: 5/25)**

Sets the minimum water supply setpoint for the customisable climate curve in Cooling mode.

**2.10 T4C1 (standard: 35 - settable: -5/46)**

Sets the minimum outdoor air temperature at which the setpoint T1SetC1 is activated for the customisable climate curve in Cooling mode.

**2.11 T4C2 (standard: 25 - settable: -5/46)**

Sets the maximum outdoor air temperature at which the setpoint T1SetC2 is activated for the customisable climate curve in Cooling mode.

**2.12 ZONE1 C-EMISSION (standard: CRP (2.1-8.1) / CVC (9.1-14.1) - settable: CRP/CVC/RAD)**

Sets the type of distribution system in Cooling mode of the system's zone 1.

**NOTE**

CRP = radiant / CVC = fan coils / RAD = radiators.

**2.13 ZONE2 C-EMISSION (standard: CRP (2.1-8.1) / CVC (9.1-14.1) - settable: CRP/CVC/RAD)**

Sets the type of distribution system in Cooling mode of the system's zone 2.

**NOTE**

CRP = radiant / CVC = fan coils / RAD = radiators.

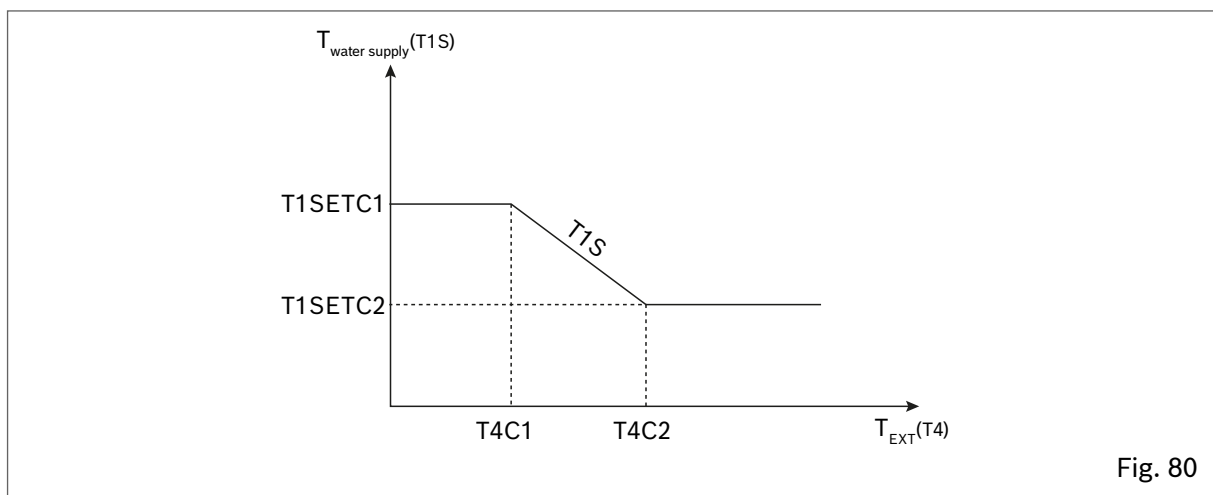

## 8.2.3 Heating mode settings

### MENU > FOR SERVICEMAN > 3. HEATING MODE

#### 3.1 HEAT MODE (standard: YES - settable: YES/NO)

Enables/disables Heating mode.

#### 3.2 t\_T4\_FRESH\_H (standard: 0.5 - settable: 0.5/6)

Sets the time when the unit updates the climate curve, adjusting it according to the outdoor air temperature.

#### 3.3 T4HMAX (standard: 25 - settable: 20/35)

Defines the maximum outdoor air temperature for which the unit can operate in Heating mode.

#### 3.4 T4HMIN (standard: -15 - settable: -25/30)

Defines the minimum outdoor air temperature for which the unit can operate in Heating mode.

#### 3.5 dT1SH (standard: 5 - settable: 2/10)

Defines the range between the water supply temperature (T1) and the setpoint (T1S) within which the unit starts to operate in Heating mode. The heat pump starts when  $T1 \leq T1S - dT1SH$  and stops when  $T1 \geq T1S$ .

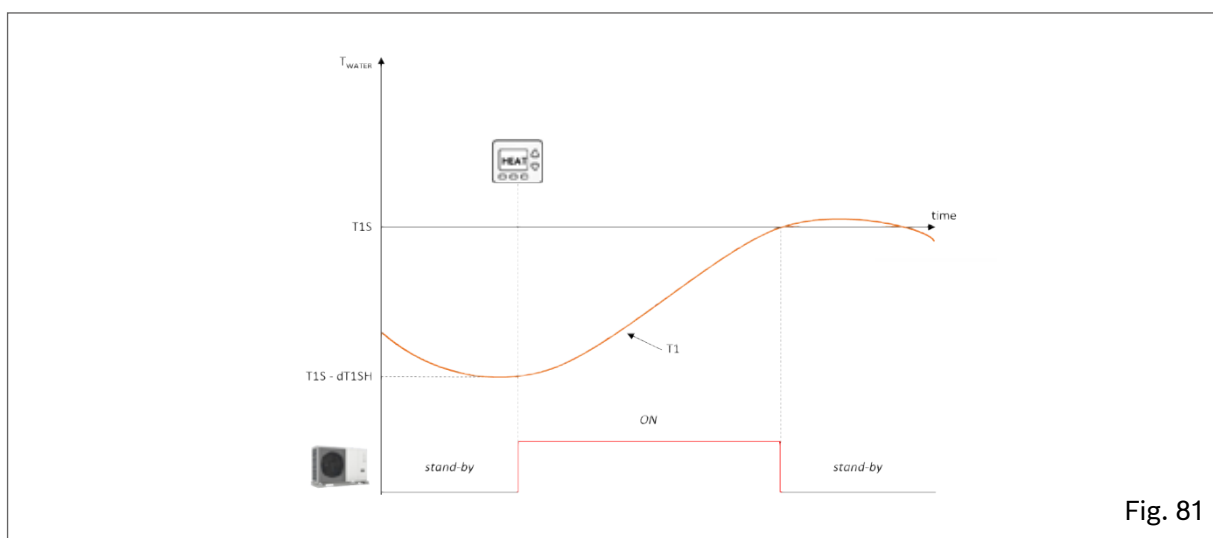

This value is strongly related to the minimum permissible water content of the circuit. A narrower control band can be accepted with a high water volume.

#### 3.6 dTSH (standard: 2 - settable: 1/10)

Defines the range between the room air temperature ( $T_a$ ) and the setpoint ( $T_S$ ) within which the unit continues to operate in Heating mode. The heat pump starts when  $T_a \leq T_S - dTSH$  and stops when  $T_a \geq T_S$ .

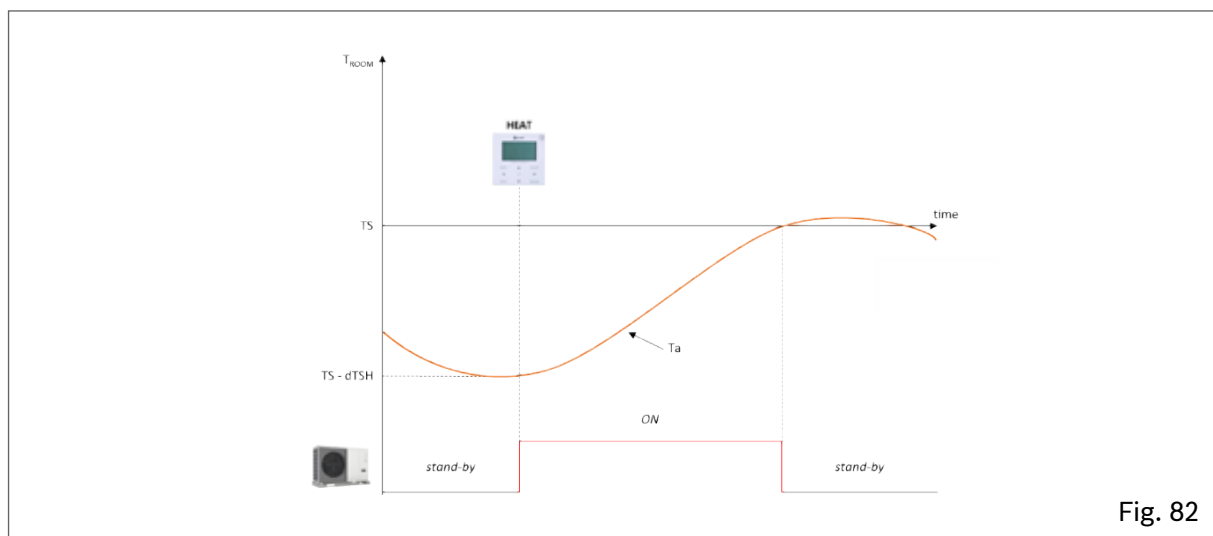

Fig. 82

**NOTE**

The parameter is only used if the unit's Heating mode control is on room air temperature.

**3.7 t\_INTERVAL\_HEAT (standard: 5 - not adjustable)**

Defines the minimum minutes between compressor shutdown and subsequent restart in Heating mode.

Among the climate curves that can be set for Heating mode, a customisable one can be set with logic as shown in the graph.

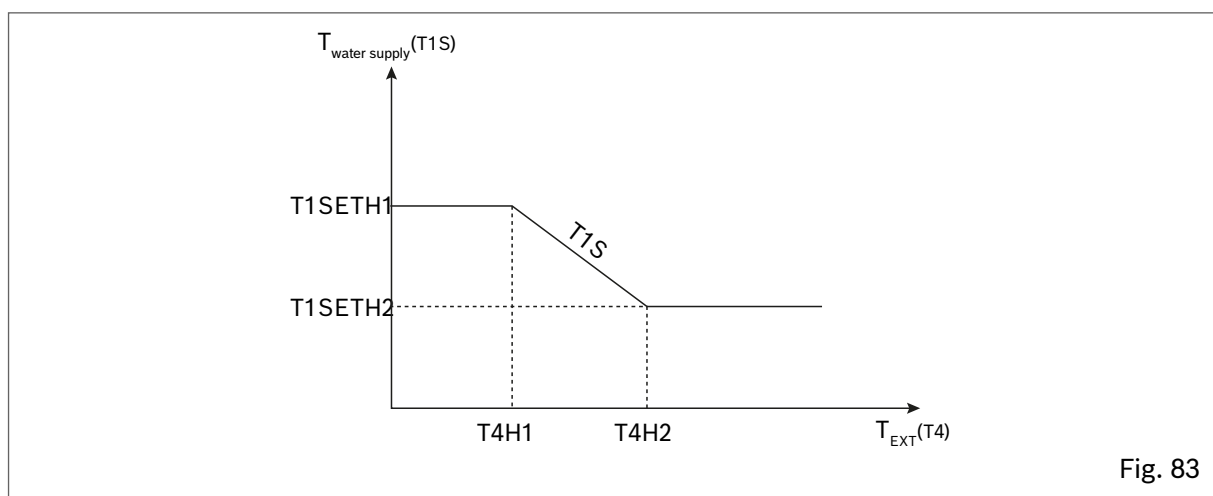

Fig. 83

**3.8 T1SetH1 (standard: 35 - settable: 25/60 (9.1-14.1) / 65 (2.1-8.1))**

Sets the maximum water supply setpoint for the customisable climate curve in Heating mode.

**3.9 T1SetH2 (standard: 28 - settable: 25/60 (9.1-14.1) / 65 (2.1-8.1))**

Sets the minimum water supply setpoint for the customisable climate curve in Heating mode.

**3.10 T4H1 (standard: -5 - settable: -25/35)**

Sets the minimum outdoor air temperature at which the setpoint T1SetH1 is activated for the customisable climate curve in Heating mode.

**3.11 T4H2 (standard: 7 - settable: -25/35)**

Sets the maximum outdoor air temperature at which the setpoint T1SetH2 is activated for the customisable climate curve in Heating mode.

**3.12 ZONE1 H-EMISSION standard: RAD (2.1-8.1) / RAD (9.1-14.1) - settable: CRP/CVC/RAD)**

Sets the type of distribution system in Heating mode of the system's zone 1.

**NOTE**

CRP = radiant / CVC = fan coils / RAD = radiators.

**3.13 ZONE2 H-EMISSION (standard: CRP (2.1-8.1) / CRP (9.1-14.1) - settable: CRP/CVC/RAD)**

Sets the type of distribution system in Heating mode of the system's zone 2.

**NOTE**

CRP = radiant / CVC = fan coils / RAD = radiators.

**3.14 t\_DELAY\_PUMP (standard: 2 - settable: 0.5/20)**

Sets the minutes of delay between compressor switch-off and pump switch-off.

## 8.2.4 Automatic mode settings

**MENU > FOR SERVICEMAN > 4. AUTO MODE**
**4.1 T4AUTOCMIN (standard: 25 - settable: 20/29)**

Defines the minimum outdoor temperature below which the heat pump will not work in Cooling mode in automatic mode.

**4.2 T4AUTOHMAX (standard: 17 - settable: 10/17)**

Defines the maximum outdoor temperature beyond which the heat pump will not work in Heating mode in automatic mode.

In combination with a possible additional electric heater and the previously set parameters, AUTO mode operation follows this pattern:

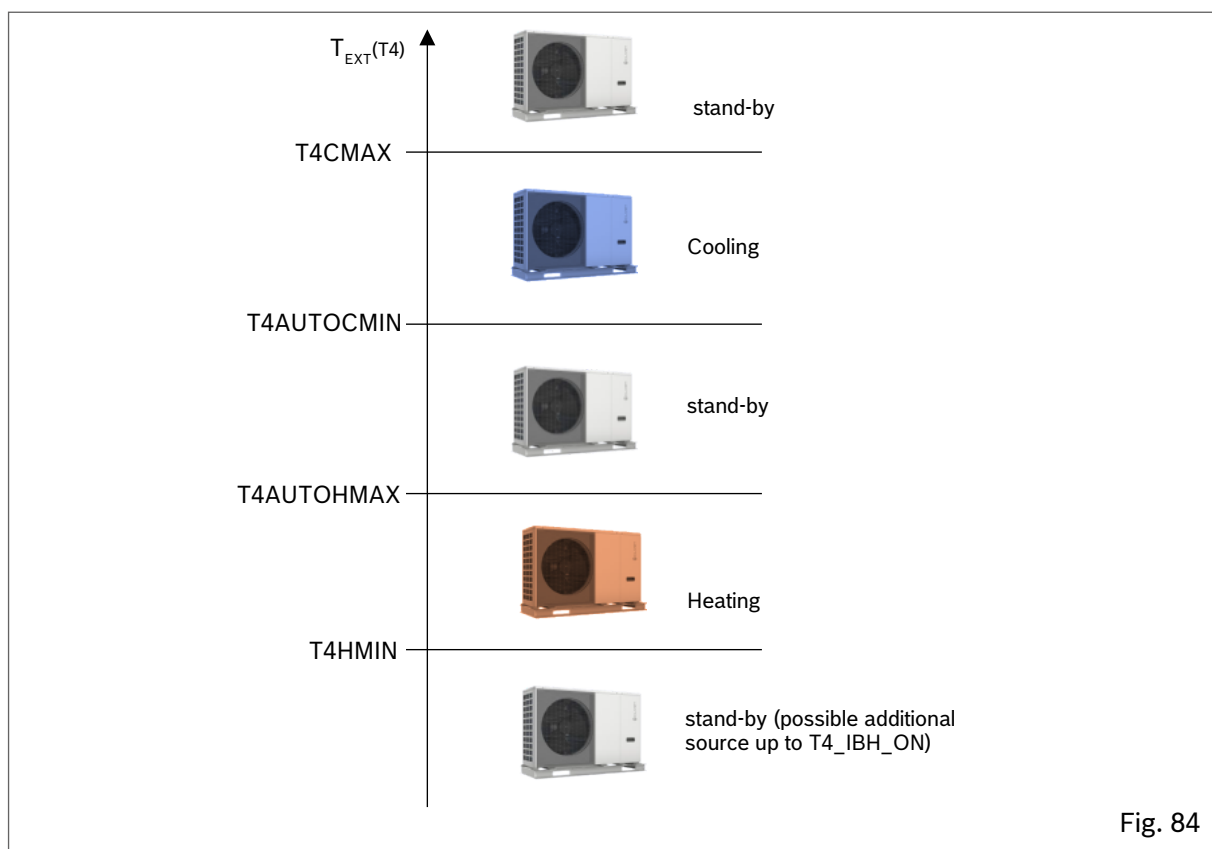

Fig. 84

## 8.2.5 Control settings

During the initial start-up phase, the type of control required for the system can be selected. The unit can be managed with control on:

- supply water temperature (T1), which has two options:
  - fixed setpoint, set from the user interface
  - auto control setpoint, calculated from a preselected climate curve
- room temperature (Ta).

### MENU > FOR SERVICEMAN > TEMP. TYPE SETTING

The request to the unit can be made from the user interface (thanks to the built-in temperature sensor) or from the electromechanical thermostat. In the second case, the zone thermostat can only control the Heat-ing/Cooling mode change if it has a double relay, otherwise it must be managed by HMI.

#### 5.1 WATER FLOW TEMP. (standard: YES - settable: YES/NO)

Enables/disables control of the unit according to the supply water temperature (T1). The user can set the system water temperature (T1S) from the HMI.

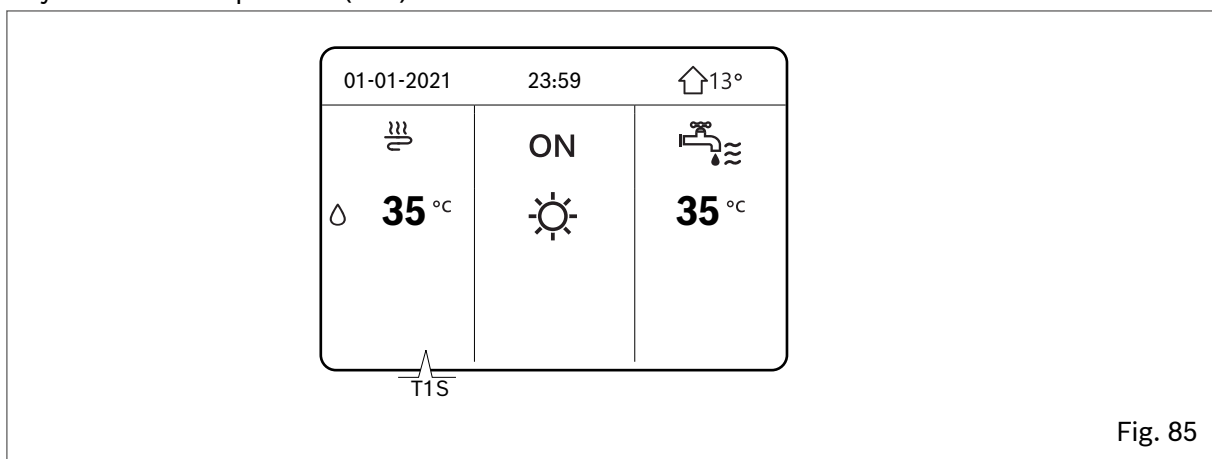

Fig. 85

#### 5.2 ROOM TEMP. (standard: NO - settable: YES/NO)

Enables/disables control of the unit according to the room air temperature (Ta). The user can set the desired temperature in the room (TS) from the HMI.

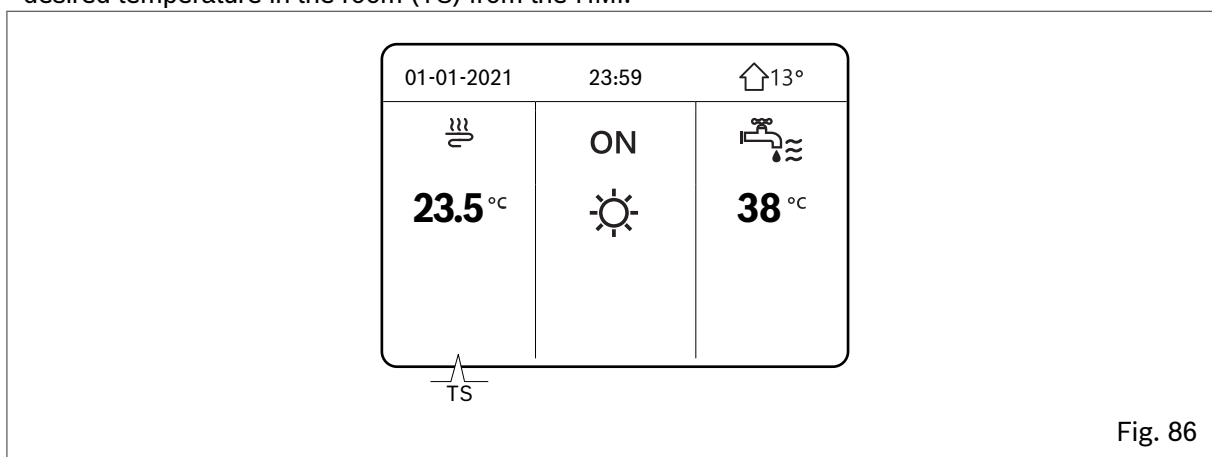

Fig. 86

#### NOTE

The supply water temperature is automatically controlled according to the climate curve.

#### 5.3 Double zone (standard: NO - settable: YES/NO)

Enables/disables management of a second system zone: a second menu dedicated to management of Zone 2 appears on the HMI display.

**NOTE**

Parameters 5.1 and 5.2 are set to YES, 5.3 will be automatically changed to YES.

The two zones can be controlled in different ways:

**Zone 1 and Zone 2**

Both are controlled according to the supply water temperature (T1).

Parameters 5.1 WATER FLOW TEMP. must be set to YES and 5.2 ROOM TEMP. must be set to NO.

Zone 1 will have setpoint T1S and Zone 2 will have setpoint T1S2 and the HMI will display these pages:

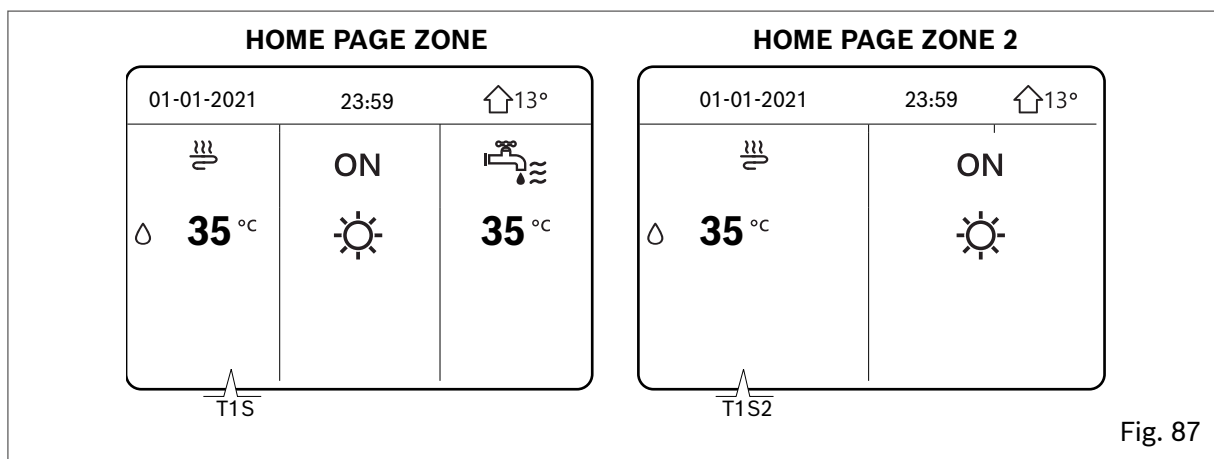

Fig. 87

**Zone 1**

With control based on the supply water temperature (T1) and Zone 2 with control based on the room temperature (Ta) it will be necessary to set parameters 5.1 WATER FLOW TEMP to YES and

**5.2 Room temp. to yes.**

Zone 1 will have setpoint T1S and Zone 2 will have setpoint T1S2 and the HMI will display these pages:

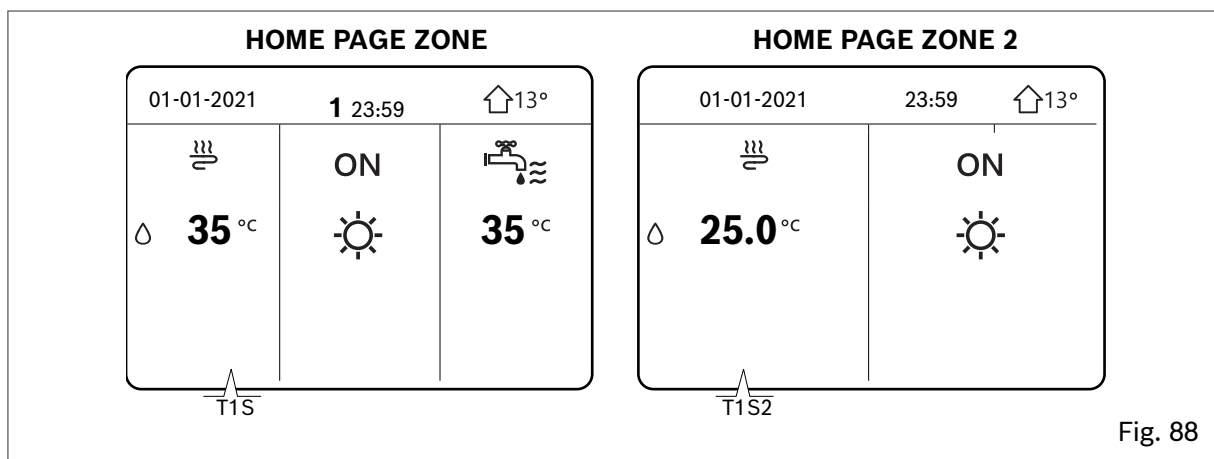

Fig. 88

**NOTE**

Zone 2 has automatically controlled supply water temperature according to the climate curve. In double zone systems, Zone 1 cannot have room air temperature control.

**NOTE**

Both zones can be equipped with an electromechanical thermostat to manage the request.

## 8.2.6 Zone thermostat settings

### MENU > FOR SERVICEMAN > 6. ROOM THERMOSTAT

A zone thermostat can be used to manage the request to the unit.

#### NOTE

The HMI must still be connected to the unit in order to manage its internal parameters.

### 6.1 ROOM THERMOSTAT (standard: NO - settable: NO/MODE SET/ONE ZONE/DOUBLE ZONE)

Enables/disables the request to the unit from zone thermostats other than the HMI.

**NO** = no zone thermostat.

**MODE SET** = single zone system with double relay zone thermostat, for managing the request to the unit and seasonal mode change (see type A connection in paragraph “7.10 Zone thermostat” on page 70). **ONE ZONE** = single zone system with zone thermostat, for managing the request to the unit (see type B connection in paragraph “7.10 Zone thermostat” on page 70). The seasonal mode change can be managed by the HMI.

**DOUBLE ZONE** = double zone system, each with zone thermostat, for managing the request to the unit (see type C connection in paragraph “7.10 Zone thermostat” on page 70). The seasonal mode change of both zones can be managed by the HMI.

## 8.2.7 Additional heating source settings

### MENU > FOR SERVICEMAN > 7. OTHER HEATING SOURCE

This section is used to adjust the parameters of an additional/backup electric heater on the system (IBH), a boiler (AHS) or a solar thermal system.

#### NOTE

These sources are optional and can be supplied separately. Only one additional Heating source, either electric heater or boiler, can be managed at the same time.

The connection and control of an electric heater in a system or boiler requires a dedicated water temperature probe, to be fitted on the downstream water supply line:

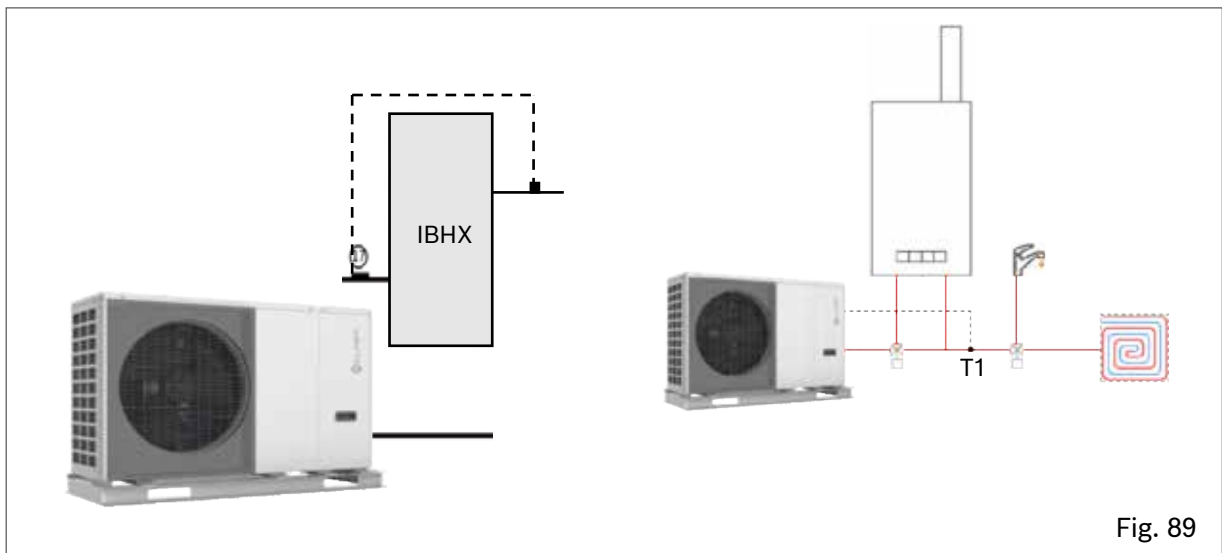

Fig. 89

The activation operating mode (in Heating, DHW production or both) must be selected with the dip-switches on the board during installation.

Activation of the additional source is linked to the simultaneous presence of 3 conditions, each of which is associated with a parameter:

- very low outdoor temperature : parameter T4\_IBH\_ON or T4\_AHS\_ON: the minimum outdoor air temperature for heat pump operation only.

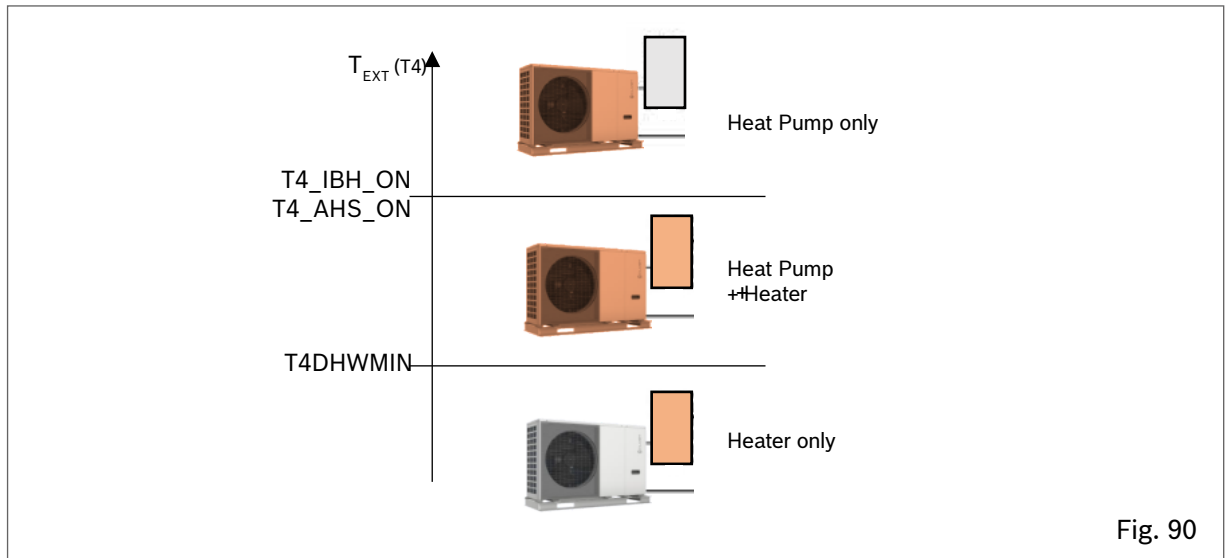

Fig. 90

**NOTE**

- To make the additional source work only as a replacement for the unit, set the parameter to the same value as T4HMIN (the minimum outdoor temperature at which the heat pump can operate).
- **supply temperature too far from the setpoint:** parameter  $dT1\_IBH\_ON$  or  $dt1\_AHS\_ON$ : the minimum  $\Delta T$  between water setpoint  $TS1$  and unit supply  $T1$ .
- **too long to reach the setpoint:** parameter  $t\_IBH\_DELAY$  or  $t\_AHS\_DELAY$ : the maximum waiting time between compressor start-up and additional source start-up.

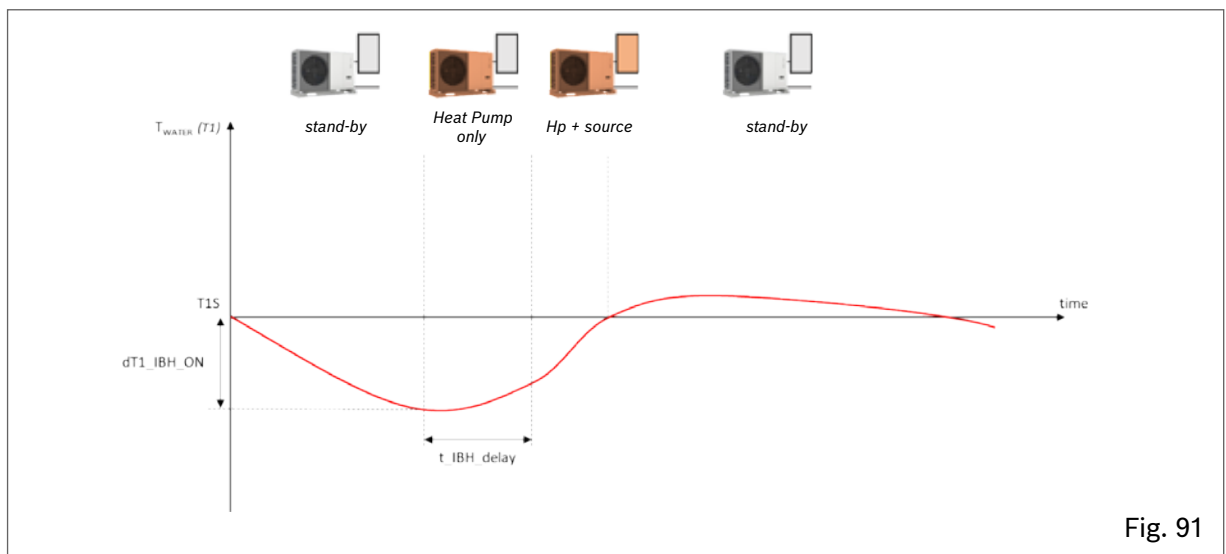

Fig. 91

**NOTE**

The BACKUP HEATER function allows start-up of the additional source to be forced from the HMI. See paragraph "8.2 Initial unit setting (requires a specialised Technician)" on page 78

**7.1  $dT1\_IBH\_ON$  (standard: 5 - settable: 2/10)**

Defines the range between the water supply temperature ( $T1$ ) and the setpoint ( $T1S$ ) beyond which the heater is switched on. When  $T1 \leq T1S - dT1S\_IBH\_O$  the heater is switched on.

**7.2  $t\_TBH\_DELAY$  (standard: 30 - settable: 15/120)**

Defines the minimum minutes between compressor start-up and heater start-up.

**7.3  $T4\_IBH\_ON$  (standard: -5 - settable: -15/30)**

Defines the outdoor temperature below which the heater can be used. If the outdoor temperature is higher than  $T4\_IBH\_ON$ , the heater cannot be used.



### 7.4 dT1\_AHS\_ON (standard: 5 - settable: 2/20)

Defines the range between the water supply temperature (T1) and the setpoint (T1S) beyond which the boiler is switched on. When  $T1S - T1 \geq dT1S\_AHS\_O$ , the boiler is switched on.

### 7.5 t\_AHS\_DELAY (standard: 30 - settable: 5/120)

Defines the minimum minutes between compressor start-up and boiler start-up.

### 7.6 T4\_AHS\_ON (standard: -5 - settable: -15/30)

Defines the outdoor temperature below which the boiler can be used. If the outdoor temperature is higher than T4\_AHS\_ON, the heater cannot be used.

### 7.7 IBH\_LOCATE (standard: 0 - settable: 0/1)

Reserved for factory settings.

### 7.8 P\_IBH1 (standard: 0 - settable: 0/20)

Defines the electric power of the heater, if present: the value set here is used to calculate the heat output and efficiency of the unit.

IBH1 must be set to the power of the first stage. The parameters do not count the power of external elements because the power port is different.

### 7.9 P\_IBH2 (standard: 0 - settable: 0/20)

Reserved for factory settings.

### 7.10 P\_TBH (standard: 2 - settable: 0/20)

Defines the electric power of the DHW tank heater, if present: the value set here is used to calculate the heat output and efficiency of the unit.

### 7.11 EnSWITCHPDC (standard: YES - settable: YES/NO)

Enables/disables the intelligent function for hybrid € switch heat pumps.

The € switch function analyses the operating conditions of the unit and uses an algorithm to calculate the minimum efficiency that the heat pump must have in order to continue to operate more economically than the boiler. Should the heat pump operate below this efficiency, the unit switches off the heat pump and only uses the boiler.

The € switch function uses the cost of fuel gas (€/Smc from a bill, to be entered in parameter GAS\_COST) and the cost of electricity (€/kWh from a bill, to be entered in parameter ELE\_COST).

---

#### NOTE

The logics that activate the boiler to supplement the capacity of the heat pump remain unchanged even with the € switch function on.

---

### 7.12 GAS\_COST (standard: 0.85 - settable: 0/5)

Defines the cost of fuel gas used to power the boiler (in €/Smc, from a bill).

---

#### NOTE

In the absence of this value, it can be estimated with data retrieved from the last bills using the simplified formula: Energy cost = (Total amount of bills [€]) / (Total amount of energy consumed [Smc]). In reality, the method is simplified because there are a number of fixed costs in the bill that are independent of actual fuel consumption. The precise calculation is beyond the scope of this manual.

---

### 7.13 ELE\_COST (standard: 0.20 - settable: 0/5)

Defines the cost of electricity used to power the unit (in €/kWh, from a bill).

---

#### NOTE

In the absence of this value, it can be estimated with data retrieved from the last bills using the simplified formula: Energy cost = (Total amount of bills [€]) / (Total amount of energy consumed [Smc]). In reality, the method is simplified because there are a number of fixed costs in the bill that are independent of actual fuel consumption. The precise calculation is beyond the scope of this manual.

---

The unit manages the AHS setpoint dynamically with a 0-10V signal, through the maximum and minimum setpoint parameters set in the boiler.

### 7.14 MAX\_SETHEATER (standard: 75 - settable: 0/75)

Defines the maximum setpoint value that can be reached by the boiler, which is used to control the 0-10V signal.

**7.15 MIN\_SETHEATER (standard: 30 - settable: 0/80)**

Defines the minimum setpoint value that can be reached by the boiler, which is used to control the 0-10V signal.

**7.16 MAX\_SIGHEATER (standard: 10 - settable: 0/10)**

Defines the signal voltage associated with the maximum setpoint value that can be set in the boiler.

**7.17 MIN\_SIGHEATER (standard: 3 - settable: 0/10)**

Defines the signal voltage associated with the minimum setpoint value that can be set in the boiler.

**7.18 DELTASOL (standard: 10 - settable: 5/20)**

Defines the range between the solar circuit temperature (Tsol) and the DHW storage tank temperature (T5) which, if the solar function is activated, starts the Pump\_s pump. The pump is switched on when  $DELTA SOL < T_{sol} - T_5$ .

## 8.2.8 Holiday away function settings

---

**MENU > FOR SERVICEMAN > 8. HOLIDAY AWAY SETTING**

The Holiday Away function can be used during long periods of absence from home and prevents the system from freezing and activating before returning home.

**8.1 T1S\_HA\_H (standard: 25 - settable: 20/25)**

Defines the water supply temperature setpoint (T1S) for the Holiday Away function.

**8.2 T5S\_HA\_DHW (standard: 25 - settable: 20/25)**

Defines the DHW storage tank temperature setpoint (T5S) for the Holiday Away function.

## 8.2.9 Serviceman contact settings

---

**MENU > FOR SERVICEMAN > 9. SERVICE CALL SETTING**

Serviceman contacts can be stored so that they are always at hand in case of need.

**PHONE NO.**

Stores a phone number.

**MOBILE NO.**

Stores a mobile phone number.

**NOTE**

To change numbers from the keypad, use the  buttons. The maximum number of characters is 14, for larger numbers you can select empty cells

## 8.2.10 Restore factory settings

---

**MENU > FOR SERVICEMAN > 10. RESTORE FACTORY SETTINGS**

The parameters can be restored to the factory settings.

## 8.2.11 Test mode settings

---

**MENU > FOR SERVICEMAN > 11. TEST RUN**

The test mode is used to check operation of the valves, air vent, pumps, Heating, Cooling and DHW.

**NOTE**

In this mode, the keypad is disabled with the exception of the  button. You can exit the test at any time by pressing this button.

**11.1 POINT CHECK**

Used to check the operation of a number of components. By selecting the component from the menu, it can be forcibly started: if it does not work, check its electrical connection.

**CAUTION**

Before activating the function, make sure the DHW tank and the system are filled with water and the air has been discharged, otherwise the unit could be damaged.



### NOTE

Navigate through the components to be tested with . Force activation of the component by setting it to ON and pressing

The components that can be activated are:

**3WAY-VALVE 1:** 3-way DHW diverter valve

**3WAY-VALVE 2:** 3-way diverter valve for unmixed double zone systems

**PUMP\_I:** primary circuit pump (P\_i)

**PUMP\_O:** secondary circuit pump (P\_o)

**PUMP\_C:** mixed circuit pump (P\_c)

**PUMPSOLAR:** solar circuit pump (P\_s)

**PUMPDHW:** DHW recirculation pump (P\_d)

**INNER BACKUP HEATER:** built-in electric heater (IBH - only for applicable configurations)

**TANK HEATER:** DHW storage tank heater (TBH)

**3-WAY VALVE 3:** 3-way valve for double zone systems for unmixed zone 2 (SV3)

### NOTE

In double zone systems with one mixed zone, SV2 is not available.

## 11.2 AIR PURGE

Starts the vent cycle, which eliminates air in the water circuit that can cause the unit to malfunction.



### CAUTION DANGER

Before activating the function, open the vent valve.

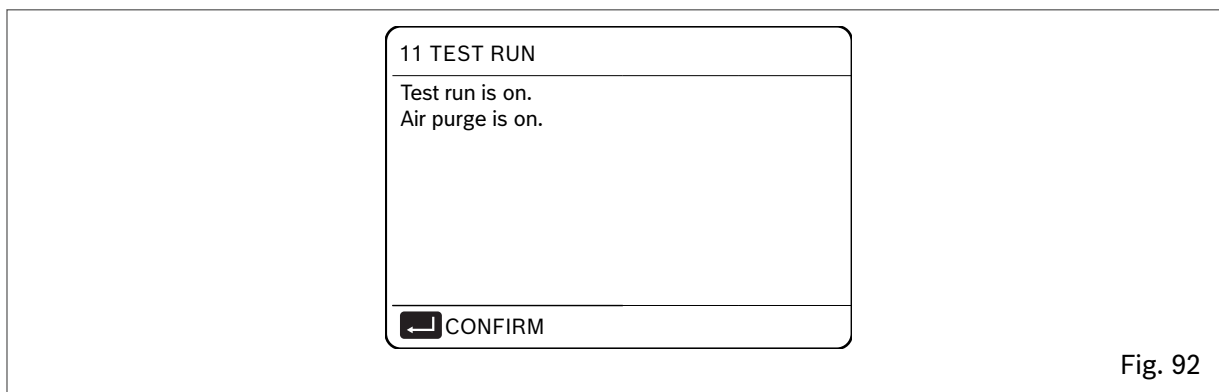

Fig. 92

The logic establishes that:

- the 3-way valve (SV1) opens and the 2-way valve (SV2) closes
- after 60 seconds, the flow switch switches off and the unit pump (P\_i) switches on for 10 minutes
- the pump stops, the 3-way valve closes and the 2-way valve opens
- after 60 seconds, the unit pump (P\_i) and the secondary pump (P\_o) switch on
- the pumps stay on for 20 minutes

### NOTE

Check the cause of any errors shown on the display during the procedure.



### 11.3 CIRCULATED PUMP RUNNING

Starts the unit's circulation pump.

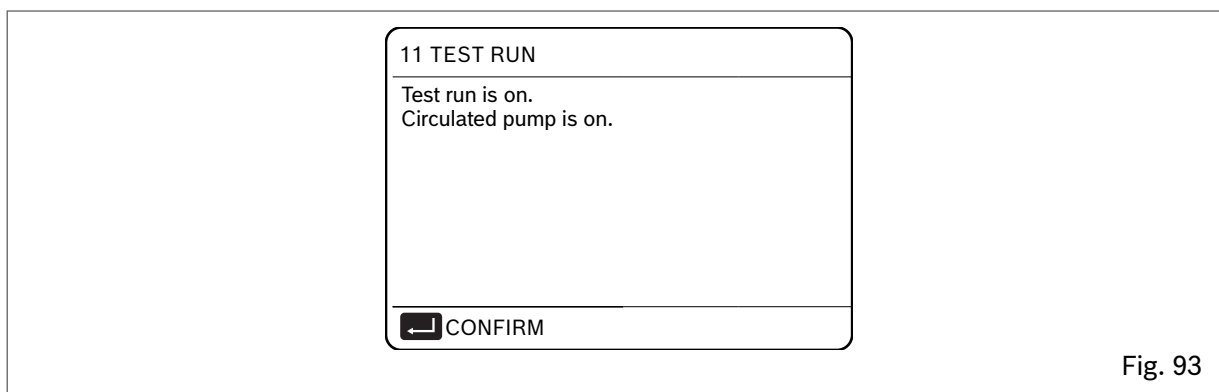

Fig. 93

The logic establishes that:

- all running components are stopped
- after 60 seconds, the 3-way valve (SV1) opens and the 2-way valve (SV2) closes
- after 60 seconds, if the flow switch detects adequate water flow, the unit's pump switches on (P<sub>i</sub>)
- after 30 seconds, the flow switch checks the water flow: if it is adequate, the pump runs for 3 minutes
- the pump stops, after 60 seconds the 3-way valve closes and the 2-way valve opens
- after 60 seconds, the unit pump (P<sub>i</sub>) and the secondary pump (P<sub>o</sub>) switch on
- after 2 minutes the flow switch checks the water flow again:
  - if it is adequate, the pumps stay on until the next keypad command
  - if it is inadequate for at least 15 seconds, the pumps stop and error E8 is displayed; the pumps stay on for 10 minutes

#### NOTE

Check the cause of any errors shown on the display during the procedure.

### 11.4 COOL MODE RUNNING

Starts the unit in Cooling mode, so that system operation can be checked.

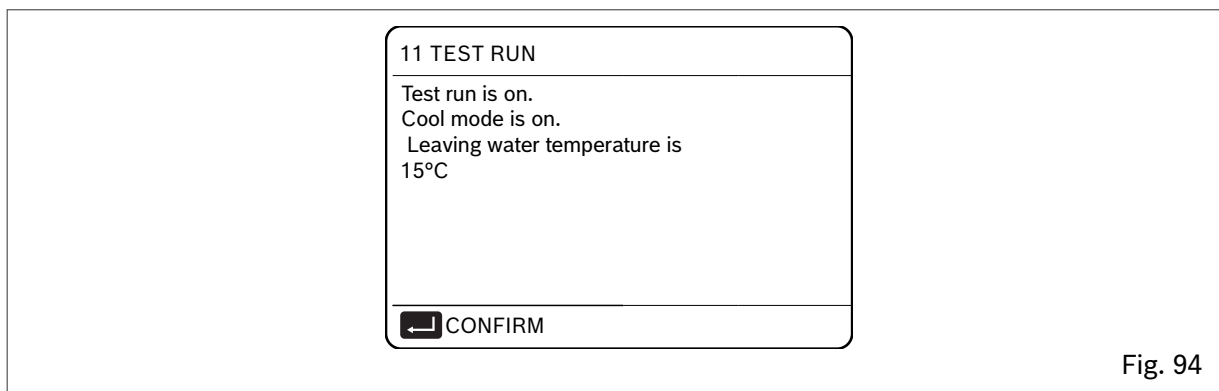

Fig. 94

The logic establishes that:

- the unit switches on in Cooling mode, with water supply setpoint at 7°C
- the actual water supply temperature is shown on the HMI display
- the unit continues to operate until the setpoint is reached or for 10 minutes

#### NOTE

Check the cause of any errors shown on the display during the procedure.

### 11.5 HEAT MODE RUNNING

Starts the unit in Heating mode, so that system operation can be checked.

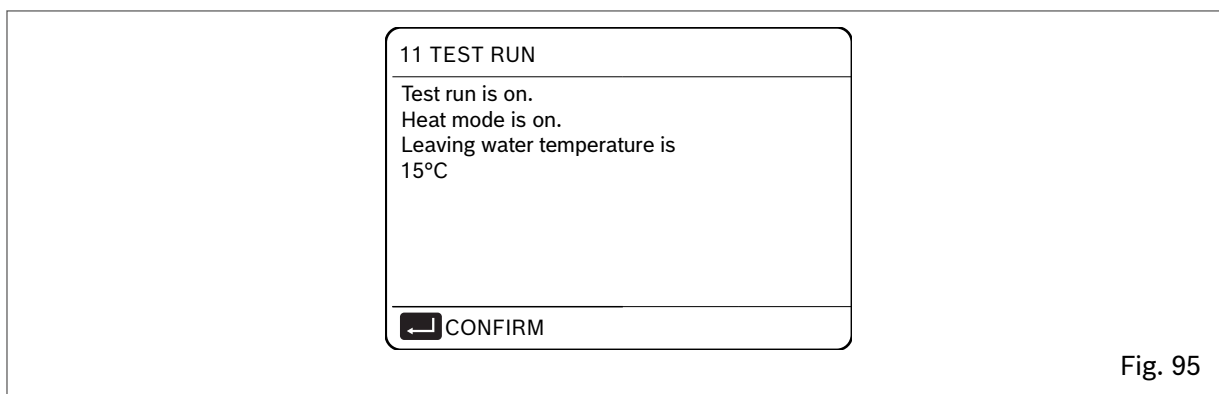

Fig. 95

The logic establishes that:

- the unit switches on in Heating mode, with water supply setpoint at 35°C
- the actual water supply temperature is shown on the HMI display after 10 minutes:
  - if present, the backup boiler (AHS) starts in support of the heat pump. If the conditions for exiting the function are not reached, the boiler continues to operate for 10 minutes, then switches off.
  - if present, the backup electric heater (IBH) starts in support of the heat pump. If the conditions for exiting the function are not reached, the heater continues to operate for 3 minutes, then switches off.
- the unit continues to operate until the setpoint is reached or for 30 minutes

**NOTE**

Check the cause of any errors shown on the display during the procedure

**11.6 DHW MODE RUNNING**

Starts the unit in DHW mode, so that system operation can be checked.

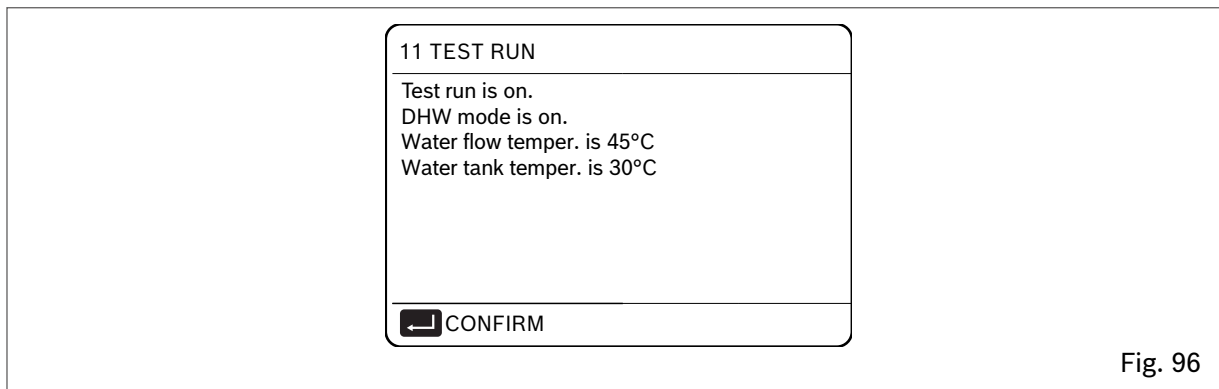

Fig. 96

The logic establishes that:

- the unit starts in DHW mode, with a DHW setpoint of 55°C
- the actual water and DHW storage tank supply temperatures are shown on the HMI display
- after 10 minutes, if present, the storage tank electric heater (TBH) starts in support of the heat pump. If the conditions for exiting the function are not reached, the heater continues to operate for 3 minutes, then switches off
- the unit continues to operate until the setpoint is reached or for 20 minutes

**NOTE**

Check the cause of any errors shown on the display during the procedure.

## 8.2.12 Special function settings

### MENU > FOR SERVICEMAN > 12. SPECIAL FUNCTION

Special functions can be used during installation or maintenance to better manage or access the system, e.g. on first start-up to run a radiant floor drying cycle or when the unit is restarted after being OFF for a long period.

#### NOTE

In this mode, the keypad is disabled.

### 12.1 PREHEATING FOR FLOOR

The function can be useful when the distribution system consists of a radiant floor: if Heating mode is activated on a floor that still contains a considerable amount of water, there is a risk that it will warp or crack. To protect the floor, a preheating cycle must be carried out, during which the temperature of the water supplied to the floor is gradually raised.

#### NOTE

If this is the first time the unit has been started up, before activating this function run the air vent function (indicated in this paragraph), in order to avoid malfunctions or damage to the system.

The operating logic is shown in the following diagram:

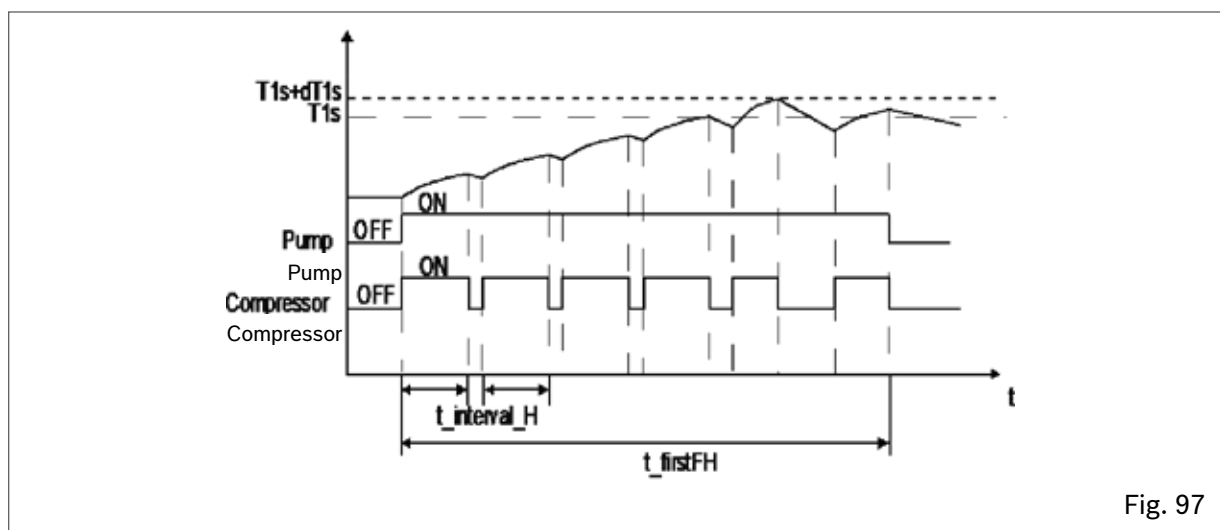

Fig. 97

The parameters that can be set for this function are:

#### **T1S (standard: 25 - settable: 25/35)**

Defines the water supply setpoint temperature for the floor preheating function.

**t\_frisFH (standard: 72 - settable: 48/96)**

Defines how long the floor preheating function runs for.

The HMI display shows the water supply temperature and the operating time of the function.

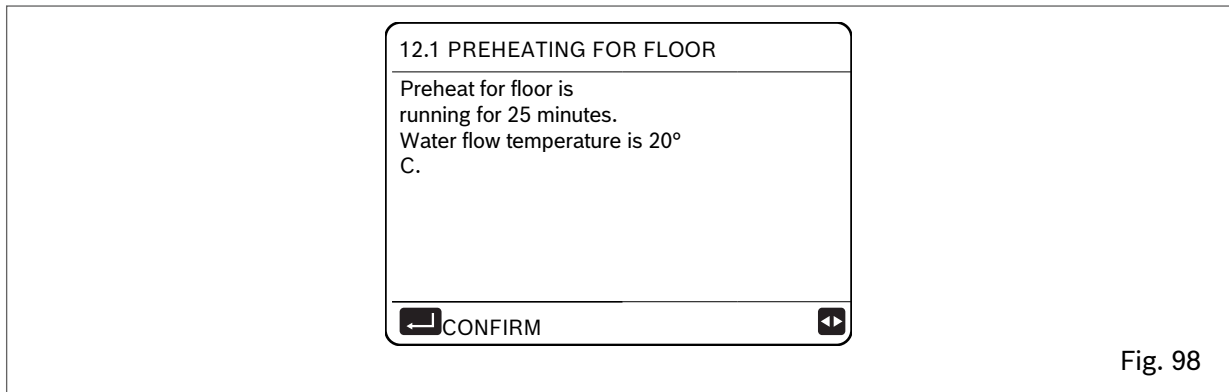

Fig. 98

**NOTE**

You can forcibly exit the function by pressing

The function can be useful for newly installed radiant floor distribution systems: during the first start-up in Heating mode, condensate can form in the floor slab or under the floor, which may cause the floor to warp or break.

To protect the floor, a drying cycle must be carried out at the first start-up, during which the temperature of the water supplied to the floor is adjusted as shown in the diagram:

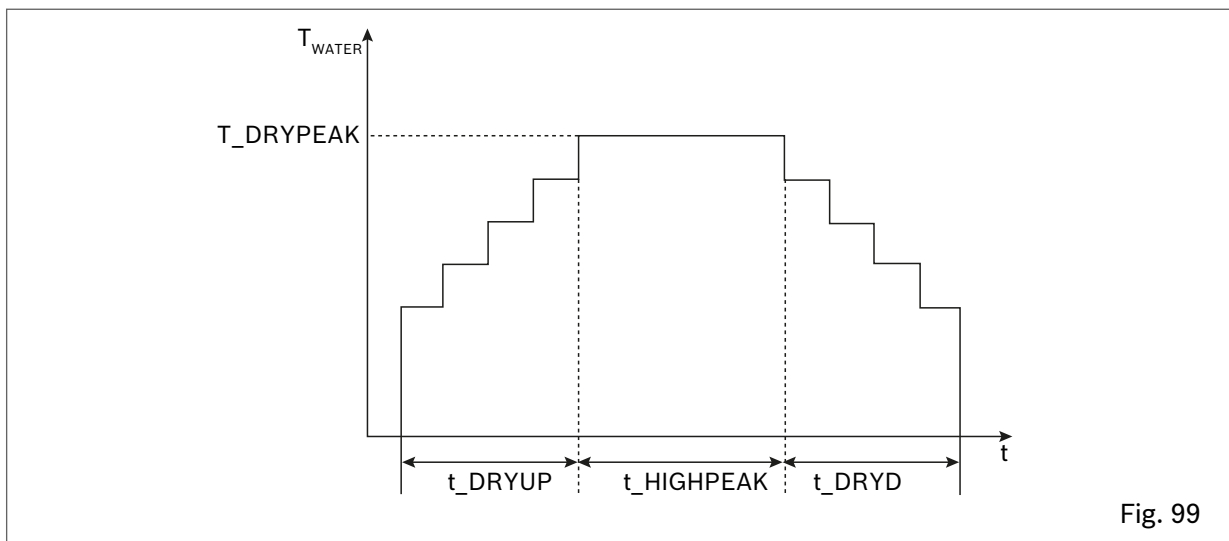

Fig. 99

**NOTE**

If this is the first time the unit has been started up, before activating this function run the air vent function (indicated in this paragraph), in order to avoid malfunctions or damage to the system. If the heat pump is out of service, the function continues using the boiler or backup electric heater, if present and enabled.

The parameters that can be set for this function are:

**WARM UP TIME (t\_DRYUP) (standard: 8 - settable: 4/15)**

Defines the number of days over which the water supply temperature is gradually increased.

**KEEP TIME (t\_HIGHPEAK) (standard: 5 - settable: 3/7)**

Defines the number of days over which the water supply temperature is kept constant.

**TEMP. DOWN TIME (t\_DRYDOWN) (standard: 5 - settable: 4/15)**

Defines the number of days over which the water supply temperature is gradually decreased.

**PEAK TEMP. (T\_DRYPEAK) (standard: 45 - settable: 30/55)**

Defines the maximum water supply temperature of the function.

**START TIME (standard: current time - settable: 00:00/23:30)**

Defines the start time of the function.

**START DATE (standard: today - settable: 1-1-2000/31-12-2099)**

Defines the start date of the function.

The HMI display shows the water supply temperature and the operating time of the function.

**NOTE**

You can forcibly exit the function by pressing .

**12.3 EMPTY AHS CIRCUIT**

Reserved parameter, do not change.

## 8.2.13 Automatic restart settings

**MENU > FOR SERVICEMAN > 13. AUTO RESTART**

The unit stores the user settings even after the power supply has been cut off.

This function sets whether the unit should automatically restart or remain on stand-by when the power supply is restored after a power failure.

The parameters that can be set for this function are:

**13.1 COOL/HEAT MODE (standard: YES - settable: YES/NO)**

Defines whether the automatic restart function is switched on for Cooling and Heating modes.

**13.2 DHW MODE (standard: YES - settable: YES/NO)**

Defines whether the automatic restart function is switched on for DHW mode.

## 8.2.14 Unit's power supply limitation settings

**MENU > FOR SERVICEMAN > 14. POWER INPUT LIMITATION**

This function is used to limit the current consumed by the unit according to predefined profiles.

Maximum current limitation [A] according to the selected profile:

Size									
	2.1-3.1	4.1-5.1	6.1M-7.1M	8.1M	6.1T-8.1T	9.1	10.1	12.1	14.1
1	18	19	30	30	14	18	21	24	28
2	16	18	28	29	13	17	20	23	27
3	15	16	26	27	12	16	19	22	26
4	14	14	24	25	11	15	18	21	25
5	13	12	22	23	10	14	17	20	24
6	12	12	20	21	9	13	16	19	23
7	12	12	18	19	9	12.5	15	18	22
8	12	12	16	17	9	12	14	17	21

The settable parameter for this function is:

**14.1 POWER LIMITATION (standard: NO - settable: NO/1 to 8)**

Enables the function and defines the maximum consumption profile.

**NOTE**

By enabling the function, unit performance will be less than nominal.

## 8.2.15 Unit input signal settings

---

### **MENU > FOR SERVICEMAN > 15. INPUT DEFINE**

This function is used to adjust and set the unit input signal and probe functions according to the requirements of the system.

The parameters that can be set for this function are:

#### **M1M2 (standard: 0 - settable: 0/1/2)**

Defines what the potential-free contact M1M2 should control (0 = remote ON/OFF; 1 = boiler electric heater (TBH); 2 = backup boiler).

#### **SMART GRID (standard: NO - settable: YES/NO)**

Enables/disables the Smart Grid function (see paragraph ["7.8 Dip-switch setting"](#) on page 64)

#### **Tw2 (standard: NO - settable: YES/NO)**

Enables/disables reception of the signal from the secondary circuit supply water temperature probe (Tw2).

#### **Tbt1 (standard: NO - settable: YES/NO)**

Enables/disables reception of the signal from the inertial storage tank temperature probe Tbt1.

#### **Tbt2 (standard: NO - settable: YES/NO)**

Reserved parameter, do not change.

#### **Ta (standard: NO - settable: YES/NO)**

Enables/disables reception of the signal from the room air temperature probe in the HMI (Ta).

#### **Ta-adj (standard: -2 - settable: -10/10)**

Sets a correction value to be considered on the value detected by the Ta probe.

#### **SOLAR INPUT (standard: 0 - settable: 0/1/2)**

In the presence of a solar thermal system, it defines how this should be managed by the unit.

- 0 = Disabled
- 1 = the unit detects the temperature of the water in the solar circuit (Tsolar) and controls the solar pump according to its own logic
- 2 = the unit receives an external ON/OFF signal (contacts SL1 / SL2, e.g. from the solar controller) and controls the solar pump

#### **F-PIPE LENGTH (standard: 0 - settable: 0/1)**

Reserved, do not use.

#### **RT/Ta\_PCB (standard: 0 - settable: 0/1)**

Reserved, do not use.

#### **Pump\_i silent mode (standard: NO - settable: YES/NO)**

Enables/disables the silent function for the unit's pump, which reduces the pump output by 5% to make the unit quieter.

#### **DFT1/DFT2 (standard: 0 - settable: 0/1)**

Defines what type of signal contacts DFT1/DFT2 should manage (0 = defrosting; 1 = alarm state).

## 8.2.16 Cascade system settings

---

### **MENU > FOR SERVICEMAN > 16. CASCADE SET**

Used to set the unit as part of a cascade system.

The parameters that can be set for this function are:

#### **16.1 PER\_START (standard: 10% - settable: 10%/100%)**

Defines the percentage of units that are activated at system start-up.

---

#### NOTE

The percentage refers to the total number of units in the cascade system, including both Master and Slave units.

---

#### **16.2 TIME\_ADJUST (standard: 5 - settable: 1/60)**

Defines the minutes after which the Master unit checks whether a Slave unit is switched on/off.

#### **16.3 ADDRESS RESET (standard: FF - settable: 0/15)**

Sets the unit address, for Slave units only.

---

#### NOTE

Slave units are auto-addressing and do not require manual address setting. FF is equivalent to setting an invalid address.

If necessary, set the address manually.

## 8.2.17 Other HMI settings

---

### **MENU > FOR SERVICEMAN > 17. HMI ADDRESS SET**

If the unit is controlled with home automation or BMS systems, it is possible to limit access from the HMI to only certain parameters.

The parameters that can be set for this function are:

#### **17.1 HMI SET (standard: 0 - settable: 0/1)**

Defines whether the HMI has limited settings (parameter = 1): in this case it can only manage ON/OFF, mode change and setpoint.

#### **17.2 HMI ADDRESS FOR BMS (standard: 1 - settable: 1/16)**

Defines the unit address for management with BMS systems.

---

#### NOTE

This parameter is only manageable if the unit has not been limited in point 17.1

---

#### **17.3 STOP BIT (standard: 1 - settable: 1/2)**

Defines the data exchange protocol between the BMS software and the HMI (it must be the same for both).

## 8.2.18 Climate curve setting

Climate curves can be selected on the user interface:

**MENU > DEFAULT TEMPERATURES > CLIMATE TEMP. SET.**

DEFAULT TEMPERATURES		
DEFAULT TEMP.	CLIMATE TEMP. SET.	ECO MODE
LOW. TEMP.COOL MODE ZONE 1		OFF
LOW. TEMP.HEAT MODE ZONE 1		OFF
LOW. TEMP.COOL MODE ZONE 2		OFF
LOW. TEMP.HEAT MODE ZONE 2		OFF
ON/OFF ON/OFF		↕

Fig. 100

During the year, the heat load of the building is highly variable depending on factors such as outdoor air temperature, insulation, thermal inertia, crowding, etc. So in Heating mode, it is advisable to use the setpoint setting on the automatically controlled water supply or on the indoor air (which controls the water supply with the climate curve).

In cooling mode, on the other hand, it is also necessary to work on the latent refrigeration load by dehumidifying. It is therefore advisable to operate the radiant or terminal distribution using the setpoint setting on the fixed water supply.

One of the default curves can still be used.

One of the curves designed to optimise the system can be selected with the user interface:

- 8 default curves for Heating mode on systems with radiant distribution.

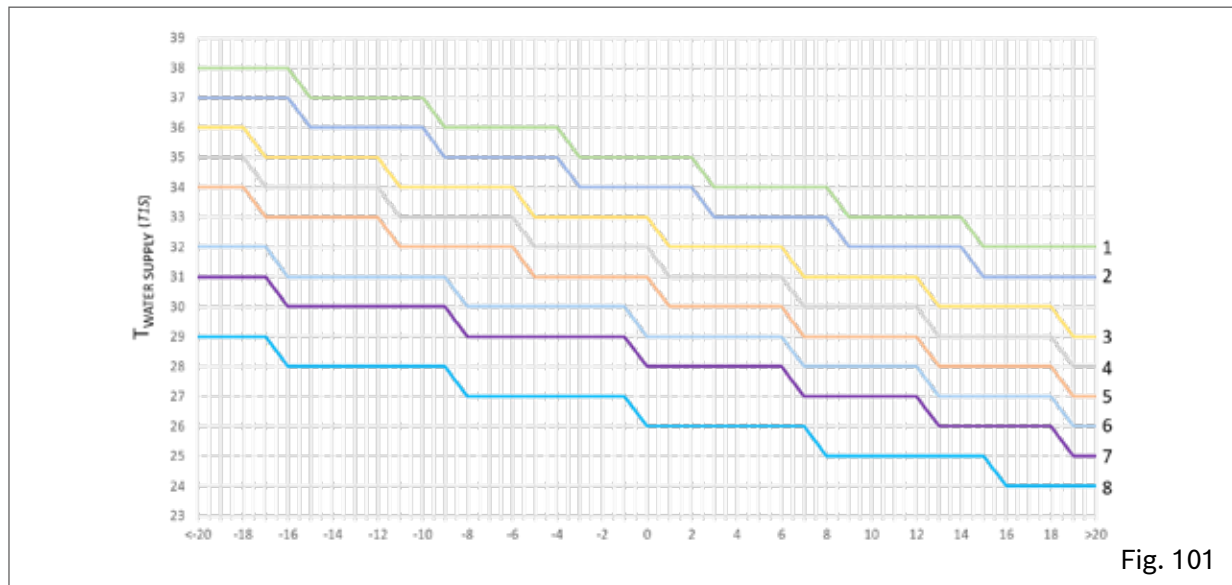

Fig. 101

### NOTE

The default curve for Heating mode is 3, for ECO mode it is 6.



- 8 default curves for Heating mode on systems with terminal distribution.

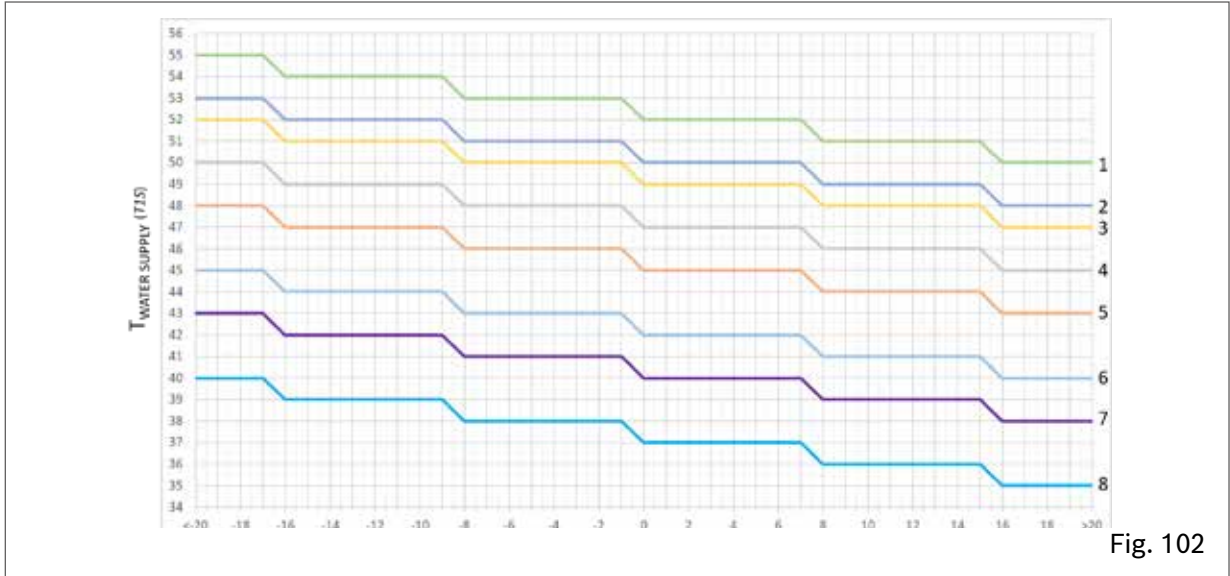

Fig. 102

### NOTE

The default curve for Heating mode is 4, for ECO mode it is 6.

- 1 customisable curve, using the outdoor air temperature (T4H1, T4H2) and water supply (T1SETH1, T1SETH2) parameters.

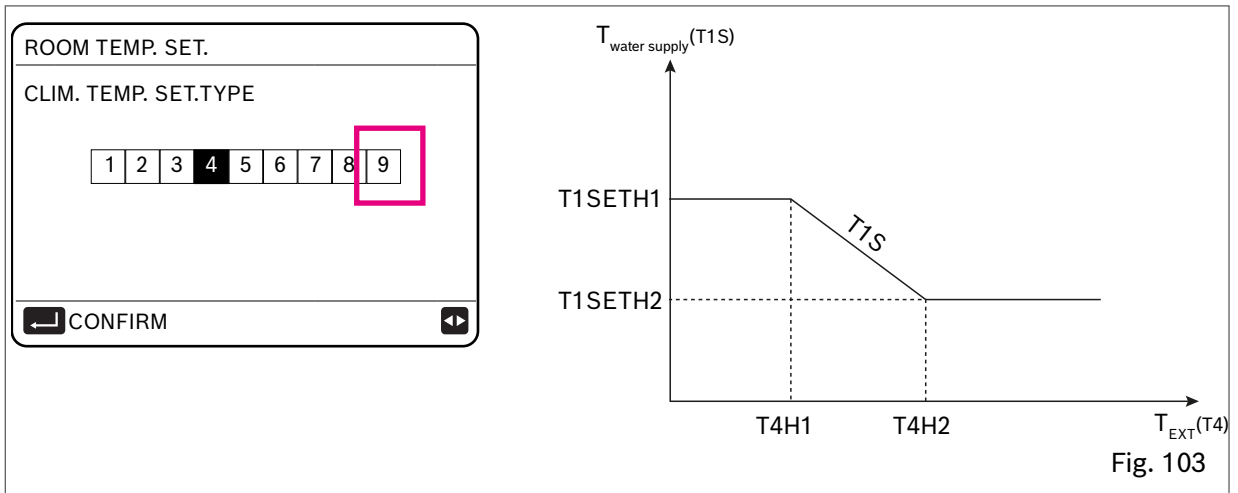

Fig. 103



- 8 default curves for Cooling mode on systems with radiant distribution.

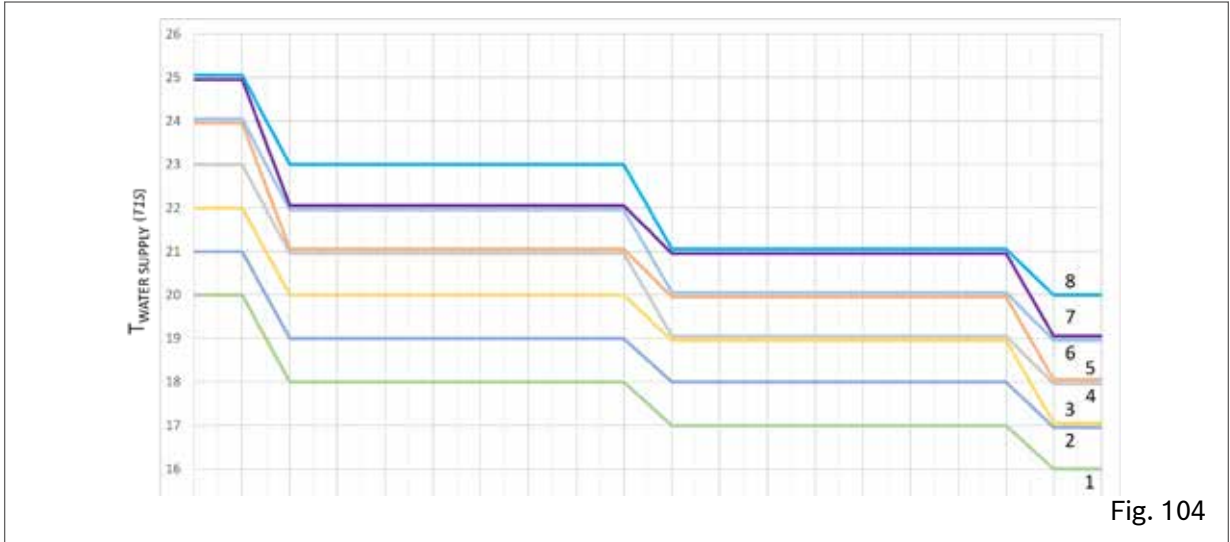

Fig. 104

**NOTE**

The default curve for Cooling mode is 4.

- 8 default curves for Cooling mode on systems with terminal distribution.

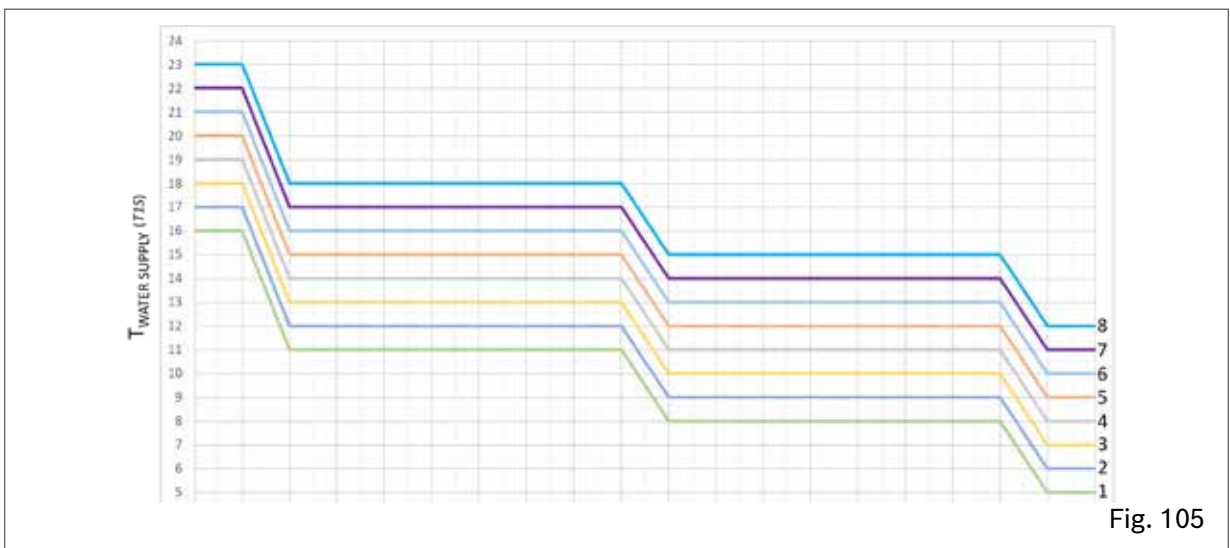

Fig. 105

**NOTE**

The default curve for Cooling mode is 4.



- 1 customisable curve, using the outdoor air temperature ( $T_{4C1}$ ,  $T_{4C2}$ ) and water supply ( $T_{1SETC1}$ ,  $T_{1SETC2}$ ) parameters.

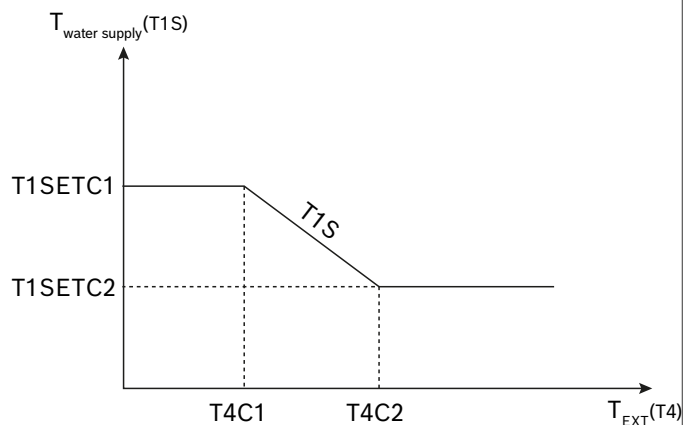
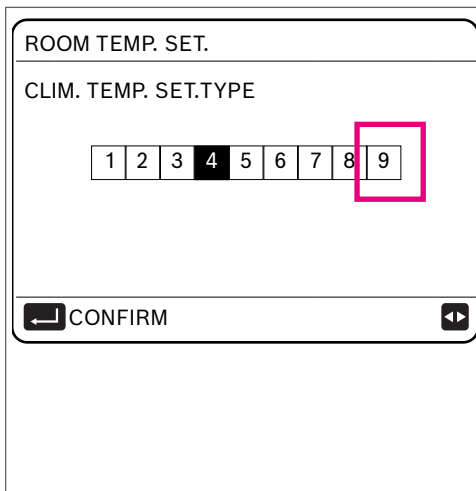

Fig. 106

## 9. Control

### 9.1 Explanation of buttons

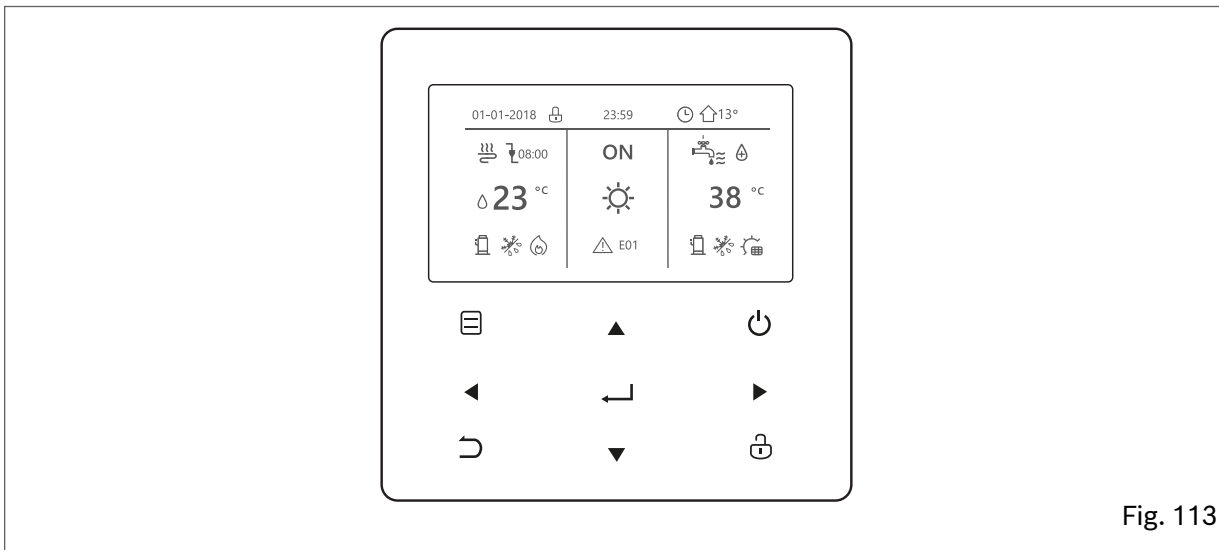









Fig. 113

Buttons		Function
	MENU	To open the various menus from the HOME page.
	ON/OFF	To switch on/off the heating/cooling modes or DHW mode To switch on/off the functions in the menu structure
	UNLOCK	Press the button for 3 seconds to Unlock/Lock the keypad
	OK	To enter a submenu To confirm entered values
 	LEFT - RIGHT DOWN - UP	To move the cursor on the screen/navigate in the menu structure/adjust parameter settings
	BACK	To return to the previous level or page. Long button press to return straight to the home page

#### Auto-restart function

The unit has an auto-restart function: in the event of a power failure (e.g. blackout), when the power supply is restored the unit restarts at the last selected settings.

## 9.2 Explanation of the display

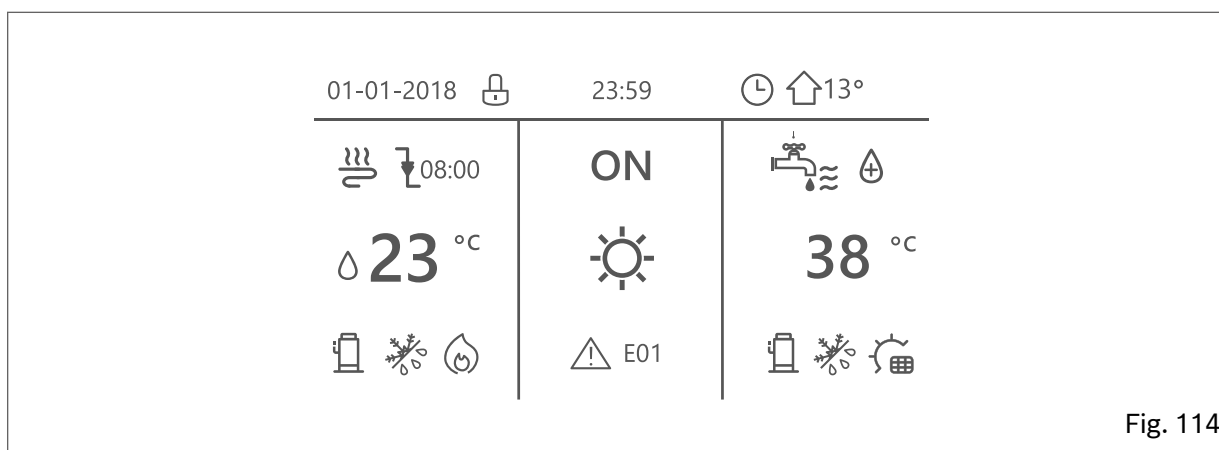











































Fig. 114

	Keypad lock		Compressor on
 8:00	At the next scheduled action, the temperature will decrease		Pump on
	The temperature does not change		Weekly schedule
	The temperature decreases		Time schedule
	The temperature increases		Outdoor temperature
	Fan coil		
	Radiator		Domestic hot water (DHW)
	Floor heating (radiant panels)		Disinfect (anti-legionella) function on
 23 °C	System water supply temperature (configurable)	ON OFF	Switch on Switch off
	Heating mode	38 °C	DHW storage tank temperature
	Cooling mode		Solar panel on
	Automatic mode		Storage tank electric heater on
	Additional heat source	 E01	Alarm
	Electric heater	 FREE	Smart grid mode

Anti-freeze mode on	Defrosting mode on	Holiday away/ at home on	Silent mode on	ECOMode on
				

	Fan coil	Radiator	Radiant panels	DHW
ON				
OFF				

Energy cost	Free	Low	High
Smart grid			
Energy source	Photovoltaics	From the network	From the network
Energy absorbed	Average	Average	Peak

## 9.3 Explanation of the display

The home page changes according to the type of system

NOTE

Configuration to be provided by the installer.

Installer



### Single zone system

- User interface control:

**MENU > FOR SERVICEMAN > ROOM THERMOSTAT > ROOM THERMOSTAT= NO**

- Thermostat control:

**MENU > FOR SERVICEMAN > ROOM THERMOSTAT > ROOM THERMOSTAT = ONE ZONE**

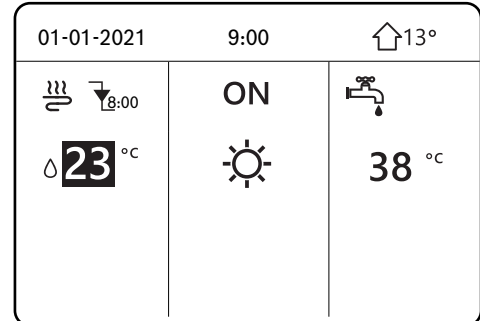

### Double zone system

- Keypad

**MENU > FOR SERVICEMAN > ROOM THERMOSTAT > ROOM THERMOSTAT= NO**

Press the back button

Select temperature type settings > double zone = yes

- Thermostat control:

**MENU > FOR SERVICEMAN > ROOM THERMOSTAT > ROOM THERMOSTAT = DOUBLE ZONE**

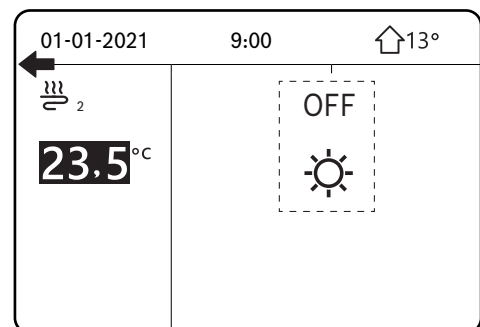
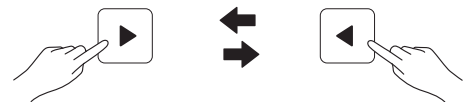
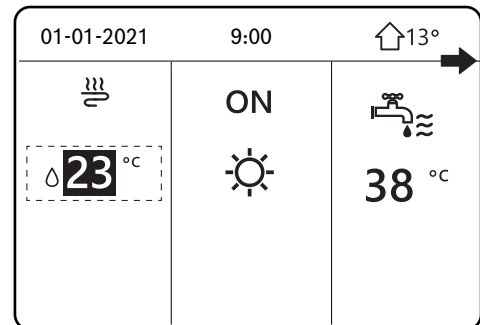

## 9.4 Menu structure

Press "UNLOCK" for 3 seconds to unlock the keypad.

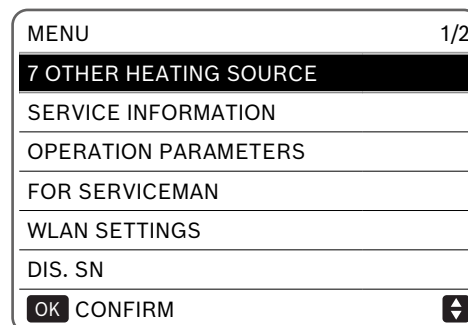
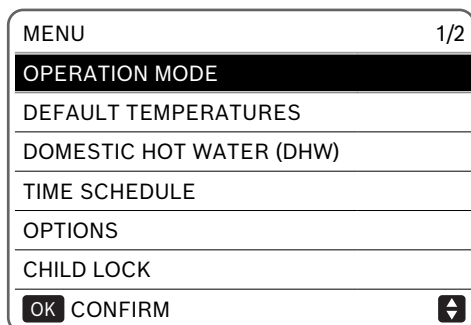

### Operation mode

Heat  
Cool  
Auto

### Default temperatures

Default temp.  
Climate Temp. Set.  
Eco mode

### Domestic hot water (DHW)

Disinfect (anti-legionella)  
Fast DHW  
Heated tank  
DHW Pump (recirculation)

### Time schedule

Timer  
Scheduled week  
Check schedule  
Cancel timer

### Options

Silent mode  
Holiday Away  
Holiday at home  
Heating backup

### Child lock

Enter password  
Cool/heat temp.control  
Cool/heat mode  
DHW temp.control  
DHW mode on/off

### Service information

Service  
Code error  
Parameters  
Display

### Operation parameters

Consultation only

### For serviceman (\*)

Enter password  
DHW mode setting  
Cool mode setting  
Heat mode setting  
Auto mode setting  
Temperature type setting  
Room thermostat  
Other heating source  
Holiday away setting  
Service call

### Restore factory settings

Test mode  
Special function  
Power input limit  
Input definition  
Casc. sys.  
HMI address set

### WLAN setting

AP mode  
Restore WLAN settings

### DIS. SN

#### NOTE

(\*) Access by password is reserved for qualified personnel. Changes to parameters may cause malfunctions

## 9.5 Home page

The Home page is the Customer's access point for daily control and varies depending on the system (and the relevant configuration set by the Technician at first start-up).

**Example for a single zone system:**

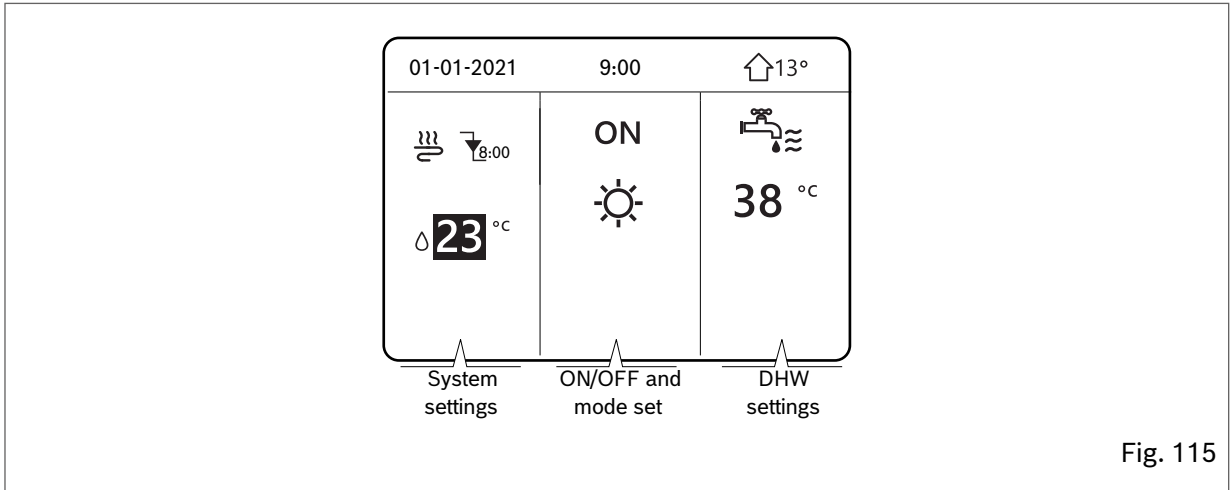

Fig. 115

Double zone systems have a second page accessible with buttons

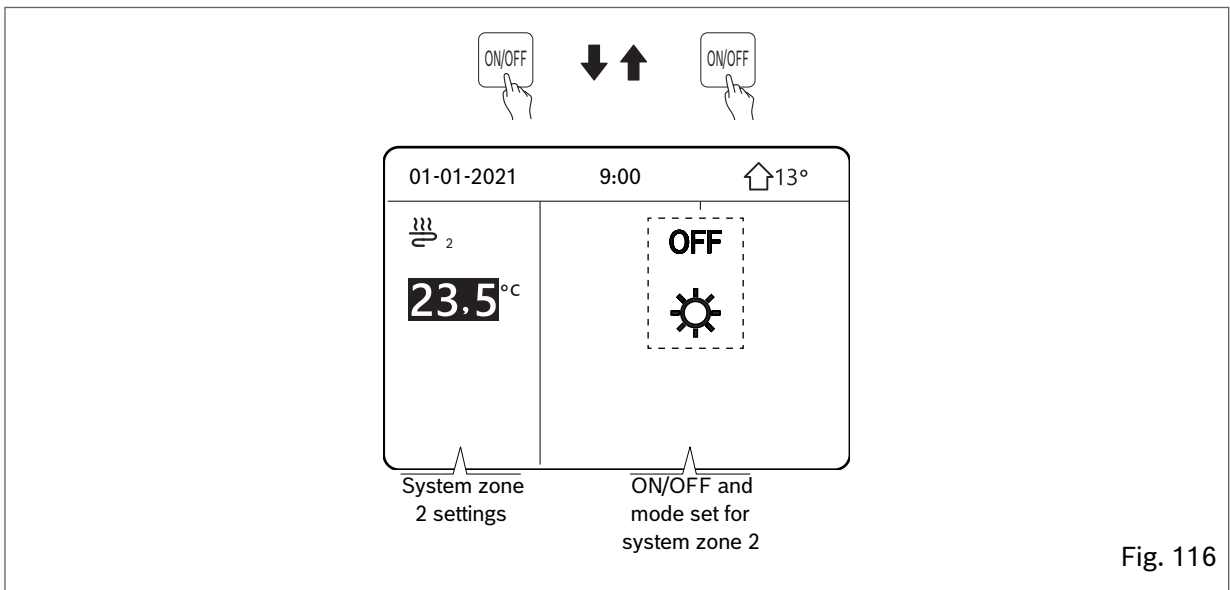

Fig. 116

## 9.6 Menu structure

About the menu structure The menu structure allows you to read and configure settings that are NOT intended for everyday use.

These instructions describe the information displayed and the operations that can be performed in the menu structure.

To go to the menu structure

- Press MENU on the keypad
- The menu structure is displayed

To navigate in the menu structure

- Press Down Up to scroll

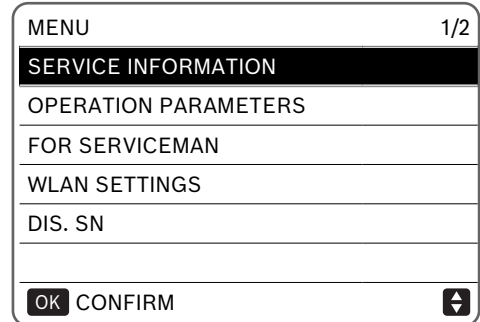
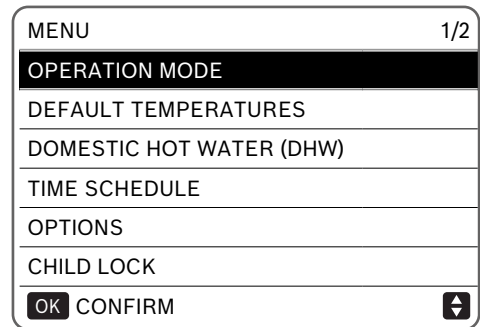

## 9.7 Unlocking the keypad

If the keypad UNLOCK icon (  ) appears on the screen, it means that the keypad is locked.

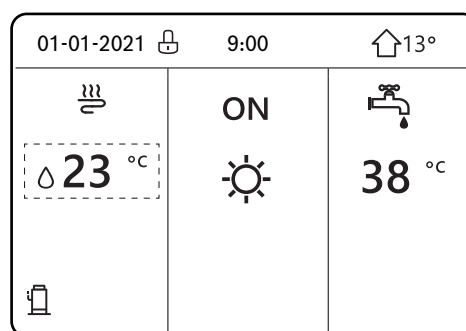

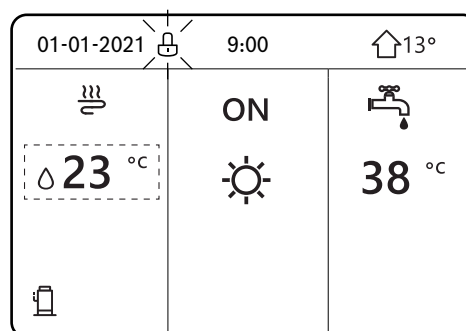

Press any button: the UNLOCK icon will flash.  
 Long press the UNLOCK button (  ).  
 The icon will disappear from the screen and the interface can be checked.

The interface locks automatically after a long period of inactivity (the default value is approximately 120 seconds but can be adjusted via the interface; see SERVICE INFORMATION).

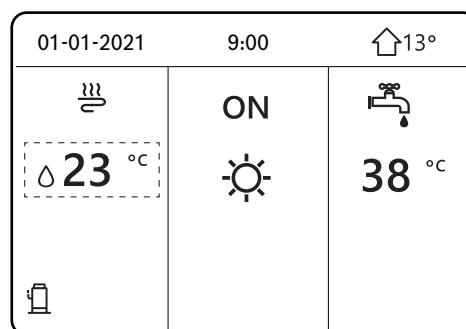

If the interface is unlocked, long press the UNLOCK button (  ) to lock the interface.



long press UNLOCK   UNLOCK long press UNLOCK

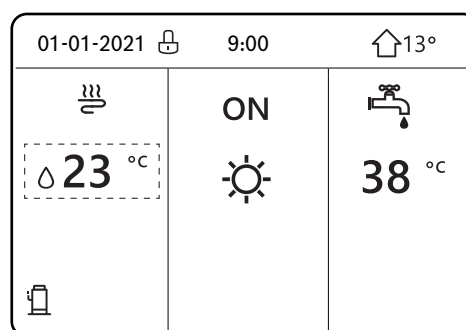

## 9.8 Unit ON/OFF

The black selection cursor must not be present when switching the unit on/off.  
Press the ON/OFF button for 5 seconds.

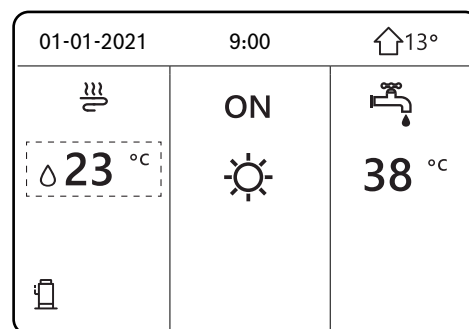

## 9.9 Controls OFF/ON

On the interface it is possible to switch on or off the unit for room heating or cooling.

- Switching the unit on or off can be controlled from the interface if the room thermostat is set to NO
  - Press the LEFT or UP button on the remote and the black cursor will appear.
- When the cursor is on the system temperature side (Cool mode, Heat mode, Auto mode), press the ON/OFF button to switch the heating or cooling mode on/off.
  - Press the RIGHT button, the cursor is on the DHW side, press the ON/OFF button to switch the DHW on/off.

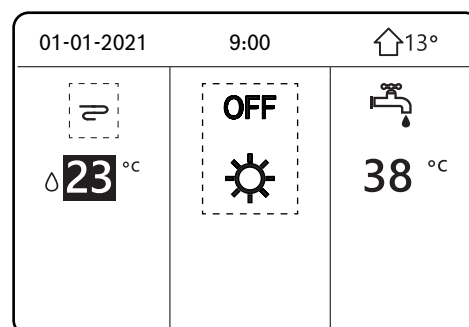
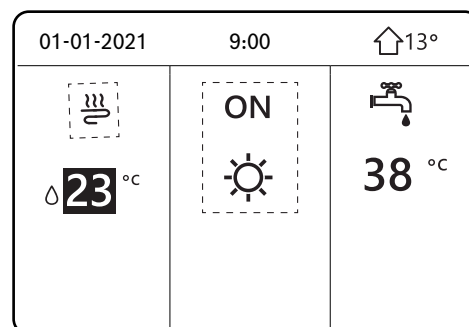
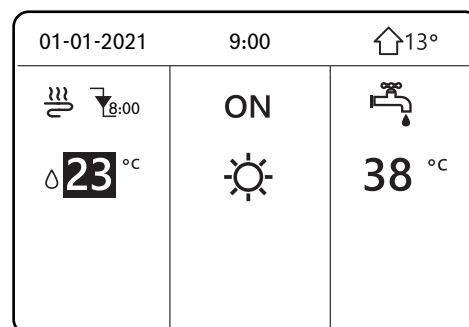



If DHW MODE SETTING is set to NO, the following pages will be displayed without the DHW function.

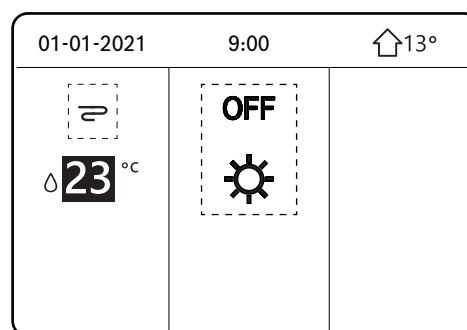
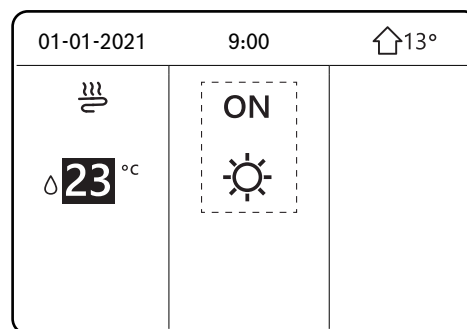

The room thermostat can be used to switch the unit on or off for heating or cooling the room.

If the room thermostat is set to:

- **DOUBLE ZONE, ONE ZONE** = the unit can be switched on or off with the room thermostat. Pressing ON/OFF on the interface displays the following page.
- **MODE SETTING** = can be switched on or off with the room thermostat and also controls the heating and cooling mode (see FOR SERVICEMAN section).

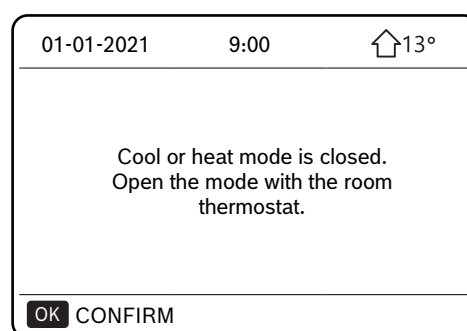



If the room thermostat is set to NO (see FOR SERVICEMAN section).

Press the LEFT or UP button on the page and the black cursor will appear.

When the cursor is on the system temperature side, press the ON/OFF button to switch the fancoils on/off.

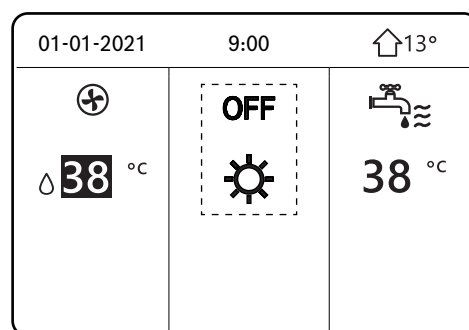
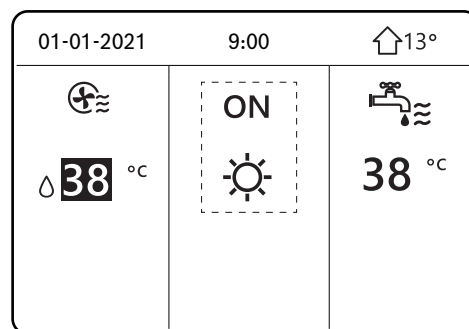

Press the RIGHT button on the page and the black cursor will appear.

When the cursor is on the system temperature side, press the ON/OFF button to switch the radiant panels on/off.

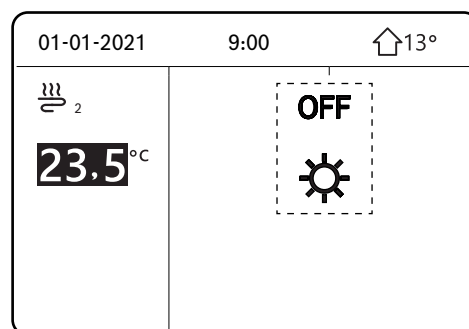
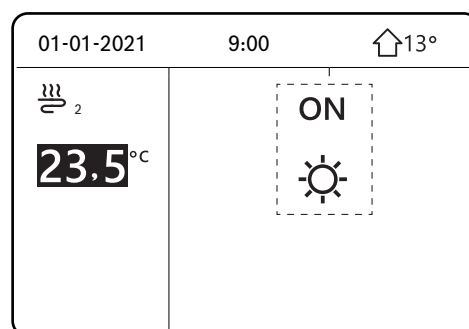



On the interface it is possible to switch on or off the unit for domestic hot water production.

Press RIGHT on the page and the black cursor will appear. When the cursor is on the DHW temperature side, press the ON/OFF button to switch the domestic hot water production on/off.

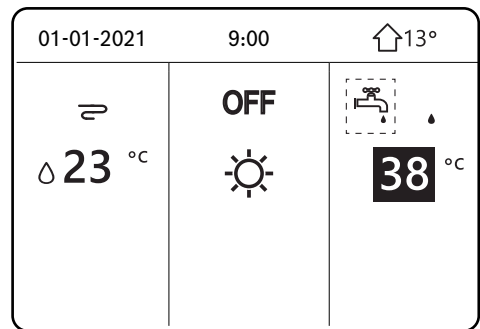
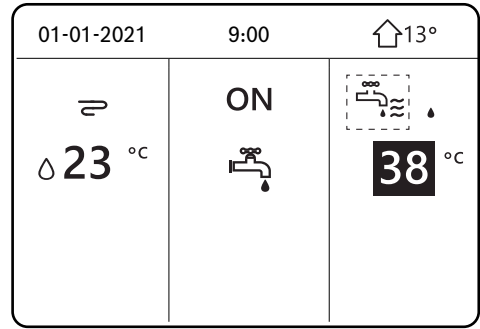
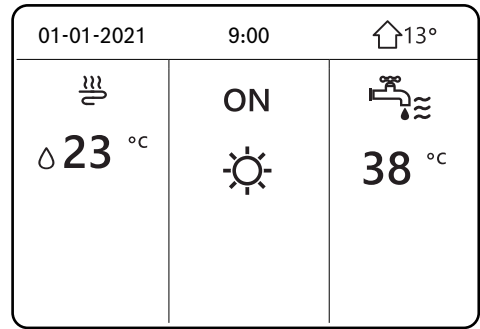

## 9.10 Temperature control

System water/DHW.

Press LEFT or UP on the page and the black cursor will appear.

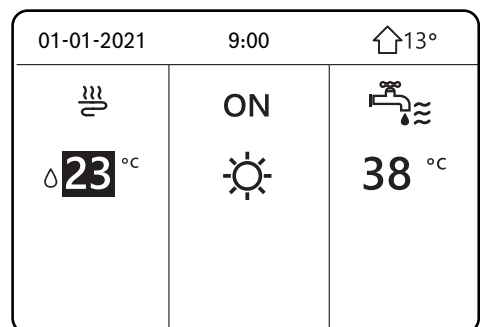



When the cursor is on the temperature, press LEFT, RIGHT to select and press Up, Down to adjust the temperature.

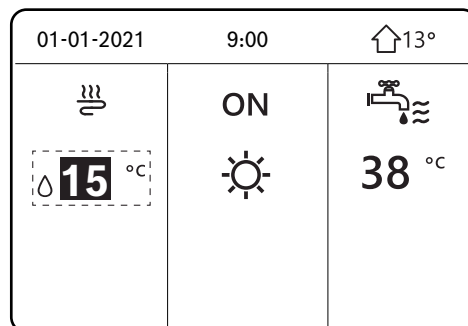
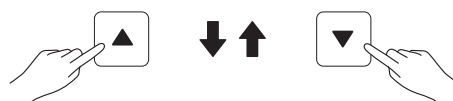
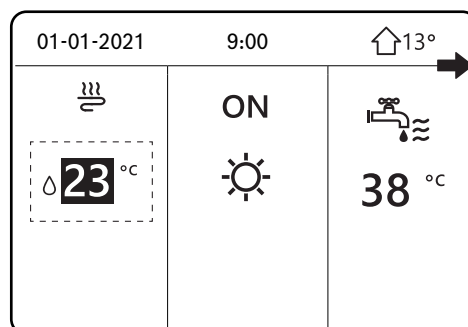
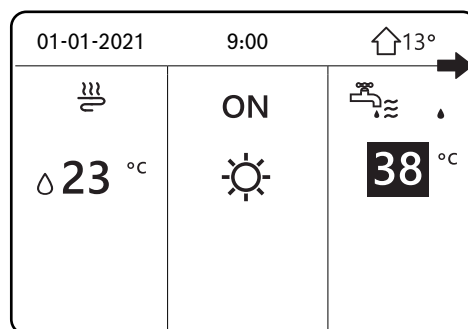
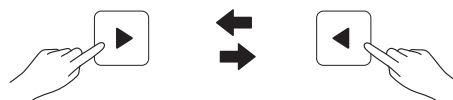
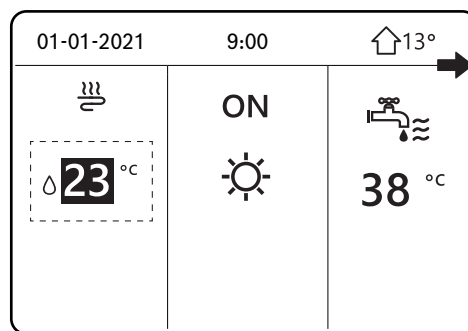



## 9.11 Select operation mode

Select the operation mode on the interface, go to **MENU > OPERATION MODE**  
Press OK.

Three modes are available:  
HEAT for heating, COOL for cooling and AUTO for automatic control.

Press LEFT or RIGHT to scroll, press OK to select.  
When the cursor is moved to an operation mode and the page is exited with the BACK button, that mode is activated even if the OK button has not been pressed.

Mode	Operation mode
	Heating Mode
	Cooling Mode
	The software automatically changes the mode according to the outdoor temperature, indoor temperature and depending on the installation settings (taking into account the monthly limitations).  NOTE automatic change is only possible under certain conditions. See FOR SERVICEMAN > AUTO MODE SETTING.

To control the operation mode with the room thermostat, see **FOR SERVICEMAN > ROOM THERMOSTAT**.

Select  
**MENU > OPERATION MODE**

Press any selection or control button and the following page will be displayed, if room thermostat = MODE SETTING is selected

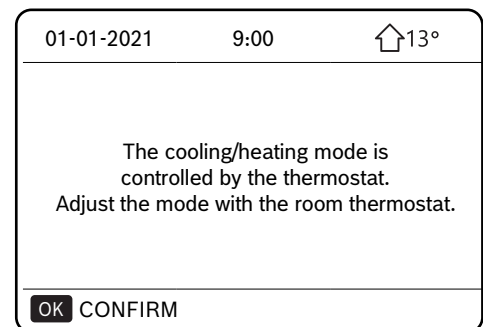
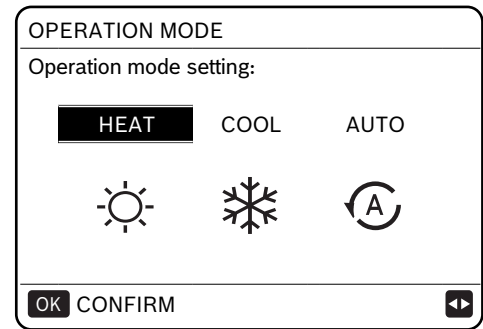

## 9.12 Default temperatures

DEFAULT TEMPERATURES has 3 modes for setting the temperature:  
 DEFAULT TEMP.\CLIM.TEMP. SET.\ECO MODE.

### Default temperatures

The DEFAULT TEMP. function is used to set temperatures for heating or cooling mode in different time slots.

The DEFAULT TEMP. function does not work under the following conditions.

- 1 When AUTO mode is on.
- 2 When the TIMER or WEEKLY SCHEDULE function is on.

Select

**MENU > DEFAULT TEMPERATURES > DEFAULT TEMP.**

Press OK.

When the DOUBLE ZONE function is on, the DEFAULT TEMP. function only works for zone 1.

Press LEFT, RIGHT, Down, Up to scroll and press Down, Up to adjust the time and temperature.

When the cursor is on n, as on the following page.

Press OK and the symbol n changes to .

Timer 1 is selected

Press OK again and the symbol  changes to n.

Timer 1 is deselected

Press LEFT, RIGHT, Down, Up to scroll and press Down, Up to adjust the time and temperature.

6 time slots and 6 temperatures can be set.

Example: it is now 9:00 a.m. and the temperature is 35°C.

DEFAULT TEMPERATURES			1/4
DEFAULT TEMP.	CLIMATE TEMP. SET.	ECO MODE	
NO.	TIME	TEMP.	
1 <input checked="" type="checkbox"/>	00:00	25° C	
2 <input type="checkbox"/>	00:00	25° C	
3 <input type="checkbox"/>	00:00	25° C	
			⬆️ ⬇️ ⬇️ ⬆️

DEFAULT TEMPERATURES			2/4
DEFAULT TEMP.	CLIMATE TEMP. SET.	ECO MODE	
NO.	TIME	TEMP.	
4 <input type="checkbox"/>	00:00	25° C	
5 <input type="checkbox"/>	00:00	25° C	
6 <input type="checkbox"/>	00:00	25° C	
			⬆️ ⬇️ ⬇️ ⬆️

DEFAULT TEMPERATURES			3/4
DEFAULT TEMP.	CLIMATE TEMP. SET.	ECO MODE	
NO.	TIME	TEMP.	
1 <input checked="" type="checkbox"/>	00:00	25° C	
2 <input type="checkbox"/>	00:00	25° C	
3 <input type="checkbox"/>	00:00	25° C	
OK <input checked="" type="checkbox"/> SELECT			⬆️ ⬇️ ⬇️ ⬆️

DEFAULT TEMPERATURES			4/4
DEFAULT TEMP.	CLIMATE TEMP. SET.	ECO MODE	
NO.	TIME	TEMP.	
1 <input checked="" type="checkbox"/>	00:00	35° C	
2 <input checked="" type="checkbox"/>	00:00	25° C	
3 <input checked="" type="checkbox"/>	00:00	35° C	
OK <input type="checkbox"/> CANCEL			⬆️ ⬇️ ⬇️ ⬆️

01-01-2021	9:00	🏠 13°
🔥 9:00	ON	
💧 35° C	☀️	
🔋		

A possible DEFAULT TEMP. schedule is shown here

**NOTE**

When the room operation mode is changed, DEFAULT TEMP. is automatically switched off and the schedule must be set again.

The DEFAULT TEMP. function can be used in Heating or Cooling mode.

NO.	TIME	TEMPERATURE
1	8:00	35°C
2	8:00	25°C
3	12:00	35°C
4	18:00	25°C
5	20:00	35°C
6	23:00	25°C

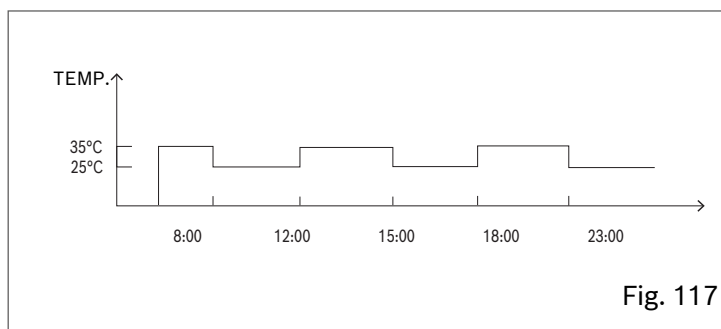

## 9.13 Climate temperature setting

CLIM. TEMP. SET.= Climate temperature setting

The CLIM. TEMP. SET. function is used to automatically set the water temperature of the system according to the outdoor temperature.

As the outdoor temperature increases, the demand for room heating is reduced.

To save energy, the desired water supply temperature is reduced when the outdoor air temperature increases in heating mode.

Select

**MENU > DEFAULT TEMPERATURES > CLIM. TEMP.**

**SET.** Press OK.

**NOTE**

CLIM. TEMP. SET. Used to select the climate curves for the various zones and different operation modes.

The possible selections depend on the options set in **MENU > FOR SERVICEMAN > COOL MODE SETTING** and **> HEAT MODE SETTING** If temperature curves are selected, the desired temperature cannot be adjusted.

DEFAULT TEMPERATURES		
DEFAULT TEMP.	CLIMATE TEMP. SET.	ECO MODE
LOW. TEMP.COOL MODE ZONE 1		OFF
LOW. TEMP.HEAT MODE ZONE 1		OFF
LOW. TEMP.COOL MODE ZONE 2		OFF
LOW. TEMP.HEAT MODE ZONE 2		OFF
ON/OFF	ON/OFF	↕



Select ON and the following page appears. Selecting climate curves

Press LEFT, RIGHT to scroll.  
Press OK to select.

ROOM TEMP. SET.

---

CLIM. TEMP. SET.TYPE

1 2 3 4 5 6 7 8 9

---

OK CONFIRM

DEFAULT TEMPERATURES

DEFAULT TEMP.	CLIMATE TEMP. SET.	ECO MODE
LOW. TEMP.COOL MODE ZONE 1	ON	ON
LOW. TEMP.HEAT MODE ZONE 1	OFF	OFF
LOW. TEMP.COOL MODE ZONE 2	OFF	OFF
LOW. TEMP.HEAT MODE ZONE 2	OFF	OFF
ON/OFF	ON/OFF	

If CLIM.TEMP.SET. is on, the temperature cannot be adjusted.

Select NO and press OK to return to the home page, select YES and press OK to switch off the CLIM.TEMP.SET. function.

Climate temp.setting function switched on.  
Switch off?

NO YES

---

OK CONFIRM

## 9.14 ECO mode

ECO mode is used to save energy.  
 The ECO MODE function is activated if DOUBLE ZONE is on NO, if DOUBLE ZONE is on YES, the ECO MODE function is not activated.  
 (see **MENU > FOR SERVICEMAN > TEMP.TYPE SETTING**)

Select  
**MENU > DEFAULT TEMPERATURES > ECO MODE**  
 Press OK  
 The following page appears

Press ON/OFF  
 The following page appears

Press LEFT, RIGHT to scroll.  
 Press OK to confirm.

Selecting climate curves

Press ON/OFF to select on/off, press Up, Down to scroll.

When the cursor is on START or END, use LEFT, RIGHT, Down, Up to scroll and Down, Up to adjust the time.

DEFAULT TEMPERATURES		
DEFAULT TEMP.	CLIMATE TEMP. SET.	ECO MODE
<b>CURRENT SET.</b>		OFF
ECO TIMER		OFF
START		08:00
END		OFF
<b>ON/OFF</b> ON/OFF		

ROOM TEMP. SET.											
CLIM. TEMP. SET.TYPE											
<table border="1" style="margin-left: auto; margin-right: auto;"> <tr> <td>1</td><td>2</td><td>3</td><td><b>4</b></td><td>5</td><td>6</td><td>7</td><td>8</td><td>9</td><td>10</td> </tr> </table>		1	2	3	<b>4</b>	5	6	7	8	9	10
1	2	3	<b>4</b>	5	6	7	8	9	10		
<b>OK</b> CONFIRM											

DEFAULT TEMPERATURES		
DEFAULT TEMP.	CLIMATE TEMP. SET.	ECO MODE
<b>CURRENT STATE</b>		OFF
ECO TIMER		OFF
START		08:00
END		OFF
<b>ON/OFF</b> ON/OFF		

DEFAULT TEMPERATURES		
DEFAULT TEMP.	CLIMATE TEMP. SET.	ECO MODE
CURRENT SET.		OFF
ECO TIMER		OFF
START		<b>08:00</b>
END		19:00
EDIT		

### NOTE

- If ECO MODE is set to ON, the desired temperature (T1S) cannot be adjusted.
- If ECO MODE is ON and ECO TIMER is OFF, the unit always operates in ECO mode.
- If ECO MODE is ON and ECO TIMER is ON, the unit operates in ECO mode according to the start and end time.

When the function is on, the  icon appears on the keypad.

## 9.15 Domestic hot water (DHW)

DHW mode for domestic hot water production includes the following functions:

- 1 DISINFECT (anti-legionella)
- 2 FAST DHW
- 3 TANK HEATING
- 4 DHW PUMP (DHW recirculation)

### 9.15.1 Disinfect (anti-legionella)



The DISINFECT function is used to eliminate legionella bacteria by raising the storage tank temperature to 65-70°C. The disinfect temperature is set in DHW MODE. See **FOR SERVICEMAN > DHW MODE > DISINFECT**.

Select  
**MENU > DOMESTIC HOT WATER > DISINFECT**.  
Press OK .

Press LEFT, RIGHT, Down, Up to scroll and press Down, Up to adjust the DAY OF OPERATION and START parameters.





Example:  
the DAY OF OPERATION is set to Friday and the start time is set to 23:00, the disinfect function will start at 23:00 on Friday. TUT = daily disinfect function

If the disinfect function is on, the following page appears.  
In DISINFECT operation the unit does not work towards the system.

DOMESTIC HOT WATER (ACS)			
DISINFECT	FAST DHW	HEAT. TANK	PUMP DHW
<b>CURRENT STATE</b>			ON
DAY OF OPERATION			FRI
START			08:00
<b>ON/OFF</b> ON/OFF			 



DOMESTIC HOT WATER (ACS)			
DISINFECT	FAST DHW	HEAT. TANK	PUMP DHW
<b>CURRENT STATE</b>			OFF
DAY OF OPERATION			FRI
START			23:00
<b>ON/OFF</b> ON/OFF			

01-01-2021 	9:00	 13°
 23,5 °C	ON 	 38 °C

## 9.15.2 Fast DHW

The fast DHW function is used to force DHW mode for domestic hot water production.

The heat pump will be switched on together with the storage tank heater and the domestic hot water temperature will be brought to setpoint.

Select

**MENU > DOMESTIC HOT WATER > FAST DHW**

Press OK.

Press ON/OFF to select ON or OFF.

### NOTE

The FAST DHW function is only run once each time it is switched on.

DOMESTIC HOT WATER (ACS)			
DISINFECT	FAST DHW	HEAT. TANK	PUMP DHW
<b>CURRENT STATE</b>			ON
<b>ON/OFF</b> ON/OFF			



DOMESTIC HOT WATER (ACS)			
DISINFECT	FAST DHW	HEAT. TANK	PUMP DHW
<b>CURRENT STATE</b>			OFF
<b>ON/OFF</b> ON/OFF			

### 9.15.3 Tank heating

The TANK HEAT. function is used to force the water to heat up in the storage tank (using the storage tank heater) in cases where the heat pump is on for heating or cooling functions but there is still a demand for domestic hot water. The TANK HEAT. function can be used to heat the water in the storage tank even if the heat pump has failed.

Select

**MENU > DOMESTIC HOT WATER > TANK HEAT.**

Press OK

DOMESTIC HOT WATER (ACS)			
DISIN- FECT	FAST DHW	HEAT. TANK	PUMP DHW
<b>CURRENT STATE</b>			ON
<b>ON/OFF</b> ON/OFF			



DOMESTIC HOT WATER (ACS)			
DISIN- FECT	FAST DHW	HEAT. TANK	PUMP DHW
<b>CURRENT STATE</b>			OFF
<b>ON/OFF</b> ON/OFF			

Press ON/OFF to select ON or OFF.

Use BACK to exit.

If the TANK HEAT. function is on, the following page appears

**NOTE**

If CURRENT STATE is OFF, the TANK HEAT. function is dis-abled. If the storage tank sensor T5 is faulty, the heater will not start.

01-01-2021	9:00	🏠 13°
☁️	ON	🚰💧
23.5 °C	☀️	38 °C
🔧		

### 9.15.4 DHW pump (recirculation) if present

To enable the function, select  
**MENU > FOR SERVICEMAN > DHW MODE SETTINGS**

Enable parameters:  
 1.4 DHW PUMP;  
 1.19 DHW PUMP OPER.TIME

The pump is to be provided by the customer.

The DHW PUMP function recirculates the water in the water system.

Select  
**MENU > DOMESTIC HOT WATER > DHW PUMP**  
 Press OK

DOMESTIC HOT WATER (DHW) 1/2			
DISINFECT	FAST DHW	HEAT. TANK	PUMP DHW
NO.	START	NO.	START
<b>T1</b> <input type="checkbox"/>	00.00	T4 <input type="checkbox"/>	00.00
T2 <input type="checkbox"/>	00.00	T5 <input type="checkbox"/>	00.00
T3 <input type="checkbox"/>	00.00	T6 <input type="checkbox"/>	00.00

DOMESTIC HOT WATER (DHW) 2/2			
DISINFECT	FAST DHW	HEAT. TANK	PUMP DHW
NO.	START	NO.	START
<b>T7</b> <input type="checkbox"/>	00.00	T10 <input type="checkbox"/>	00.00
T8 <input type="checkbox"/>	00.00	T11 <input type="checkbox"/>	00.00
T9 <input type="checkbox"/>	00.00	T12 <input type="checkbox"/>	00.00

Scroll to n and press OK to select or deselect (  timer selected.  timer deselected.)

Press LEFT, RIGHT, Down, Up to scroll and press Down, Up to adjust the parameters.

For example: the DHW PUMP parameter has been set (see FOR SERVICEMAN > DHW MODE SETTING).  
 The operating time of the PUMP is adjustable with the parameters.

DOMESTIC HOT WATER (DHW) 1/2			
DISINFECT	FAST DHW	HEAT. TANK	PUMP DHW
NO.	START	NO.	START
<b>T1</b> <input checked="" type="checkbox"/>	00.00	T4 <input type="checkbox"/>	00.00
T2 <input type="checkbox"/>	00.00	T5 <input type="checkbox"/>	00.00
T3 <input type="checkbox"/>	00.00	T6 <input type="checkbox"/>	00.00

Schedule example:

NO.	TIME
1	6:00
2	7:00
3	8:00
4	9:00

Parameter 1.19 DHW PUMP OPER.TIME has been set at 30 minutes, the pump will start at the following times

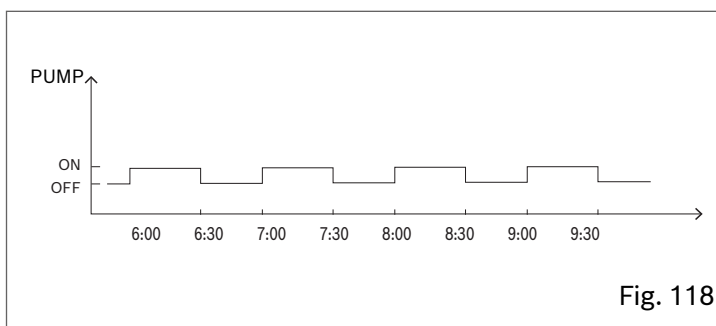

## 9.16 Time schedule

The menu includes the following functions:

- 1 TIMER for daily schedule.
- 2 WEEKLY SCHED. for weekly schedule.
- 3 SCHED. CHECK to check the schedule.
- 4 CANCEL TIMER to delete the schedule

### 9.16.1 TIMER

If the weekly schedule is ON and the TIMER function is OFF, the setting that is on takes precedence.

If the TIMER function is on, the ☹ icon appears on the home page.

Press LEFT, RIGHT, Down, Up to scroll and press Down, Up to adjust the time, mode and temperature.

Scroll to n and press OK to select or deselect. (☑ timer selected, ☐ timer deselected).

6 time slots can be set

If you want to delete the TIMER, move the cursor to ☑ and press OK, ☑ changes to ☐, the timer switches off.

If a start time is set later than the end time, or a temperature outside the allowed range is set for the chosen operation mode, the following page appears.

TIME SCHEDULE					1/2
TIMER	WEEK. SCHED.	SCHED. CHECK	CANCEL TIMER		
NO.	START	END	MODE	TEMP.	
1	<input type="checkbox"/>	00.00	00.00	HEAT	0°C
2	<input type="checkbox"/>	00.00	00.00	HEAT	0°C
3	<input type="checkbox"/>	00.00	00.00	HEAT	0°C

TIME SCHEDULE					2/2
TIMER	WEEK. SCHED.	SCHED. CHECK	CANCEL TIMER		
NO.	START	END	MODE	TEMP.	
4	<input type="checkbox"/>	00.00	00.00	HEAT	0°C
5	<input type="checkbox"/>	00.00	00.00	HEAT	0°C
6	<input type="checkbox"/>	00.00	00.00	HEAT	0°C

TIME SCHEDULE			
TIMER	WEEK. SCHED.	SCHED. CHECK	CANCEL TIMER
Timer 1 not required The start time is the same as the end time.			
<input type="button" value="OK"/> CONFIRM			

Example:  
Setting 6 time slots:

NO.	START	END	MODE	TEMP
T1	1:00	3:00	DHW	50°C
T2	7:00	9:00	HEAT	28°C
T3	11:30	13:30	COOL	20°C
T4	14:30	16:30	HEAT	28°C
T5	15:00	19:00	COOL	20°C
T6	18:00	23:30	DHW	50°C

The unit is switched on as follows:

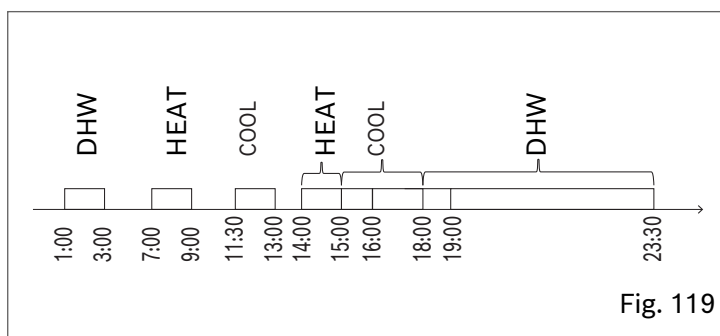

Fig. 119

Operation of the control unit according to the schedule:	
TIME	Control unit operation
1:00	DHW mode is switched ON
3:00	DHW mode is switched OFF
7:00	Heating mode is switched ON
9:00	Heating mode is switched OFF
11:30	Cooling mode is switched ON
13:00	Cooling mode is switched OFF
14:00	Heating mode is switched ON
15:00	Cooling mode is switched ON and Heating mode is switched OFF
16:00	Heating mode is switched OFF
18:00	DHW mode is switched on
19:00	Cooling mode is switched OFF
23:00	DHW mode is switched OFF

**NOTE**

If the start time and the end time are the same in the same time schedule, the TIMER function is not valid.

## 9.16.2 Weekly schedule

If the timer is on and the weekly schedule is off, the most recent setting is valid.

If the WEEKLY SCHED. function is on, 7 is displayed on the home page

Select

**MENU > SCHEDULE > WEEKLY SCHED.**

Press OK

Select the days of the week you wish to schedule.

Press LEFT or RIGHT to scroll through the days, press OK to select or deselect the day.

If the day appears as “ **MON** ”, it means that it is selected.

If it appears as “ MON ”, it means that it is deselected.

**NOTE**

To enable the WEEKLY SCHED. function, at least two days must be scheduled.

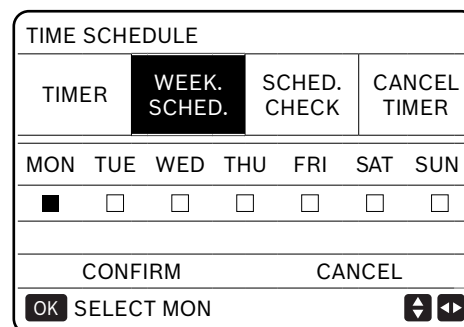

Press LEFT or RIGHT to select the days, press OK to select or deselect the day.  
The days from Monday to Friday are selected and have the same schedule.

TIME SCHEDULE							
TIMER	WEEK. SCHED.		SCHED. CHECK	CANCEL TIMER			
MON	TUE	WED	THU	FRI	SAT	SUN	
<input type="checkbox"/>	<input type="checkbox"/>	<input type="checkbox"/>	<input type="checkbox"/>	<input checked="" type="checkbox"/>	<input type="checkbox"/>	<input type="checkbox"/>	
CONFIRM				CANCEL			
OK		SELECT FRI		<input type="button" value="↕"/> <input type="button" value="↔"/>			

Keep pressing RIGHT to CONFIRM, press OK

TIME SCHEDULE							
TIMER	WEEK. SCHED.		SCHED. CHECK	CANCEL TIMER			
MON	TUE	WED	THU	FRI	SAT	SUN	
<input type="checkbox"/>	<input type="checkbox"/>	<input type="checkbox"/>	<input type="checkbox"/>	<input checked="" type="checkbox"/>	<input type="checkbox"/>	<input type="checkbox"/>	
CONFIRM				CANCEL			
OK		SELECT FRI		<input type="button" value="↕"/> <input type="button" value="↔"/>			

The following pages appear.  
Press LEFT, RIGHT, Down, Up to scroll and adjust the time, mode and temperature. Start and stop times, operation mode and temperature can be set. The modes available are Heat mode, Cool mode and DHW mode.

To set the schedule, refer to the daily timer schedule.

The end time must be later than the start time, otherwise the timer schedule will have no effect; the 'Timer not needed, cannot be activated' indication will appear.

TIME SCHEDULE						1/2
TIMER	WEEK. SCHED.		SCHED. CHECK	CANCEL TIMER		
NO.	START	END	MODE	TEMP.		
1	<input type="checkbox"/>	00.00	00.00	HEAT	0°C	
2	<input type="checkbox"/>	00.00	00.00	HEAT	0°C	
3	<input type="checkbox"/>	00.00	00.00	HEAT	0°C	
						<input type="button" value="↕"/> <input type="button" value="↔"/>

TIME SCHEDULE						2/2
TIMER	WEEK. SCHED.		SCHED. CHECK	CANCEL TIMER		
NO.	START	END	MODE	TEMP.		
4	<input type="checkbox"/>	00.00	00.00	HEAT	0°C	
5	<input type="checkbox"/>	00.00	00.00	HEAT	0°C	
6	<input type="checkbox"/>	00.00	00.00	HEAT	0°C	
						<input type="button" value="↕"/> <input type="button" value="↔"/>

### 9.16.3 Schedule check

The schedule check can only check the weekly schedule. Select  
**MENU > SCHEDULE > SCHED. CHECK**

Press OK

Press Down, Up to display the schedule from Monday to Sunday.

TIME SCHEDULE				1/2
TIMER	WEEK. SCHED.	<b>SCHED. CHECK</b>	CANCEL TIMER	
WEEK. SCHED. CHECK				
OK CONFIRM				↕ ↗

WEEK. SCHED. CHECK					
DAY	NO.	MODE	SET.	START	END
	T1	<input type="checkbox"/> HEAT	0°C	00.00	00.00
	T2	<input type="checkbox"/> HEAT	0°C	00.00	00.00
MON	T3	<input type="checkbox"/> HEAT	0°C	00.00	00.00
<input type="checkbox"/>	T4	<input type="checkbox"/> HEAT	0°C	00.00	00.00
	T5	<input type="checkbox"/> HEAT	0°C	00.00	00.00
<input type="checkbox"/>	T6	<input type="checkbox"/> HEAT	0°C	00.00	00.00

### 9.16.4 Cancel timer

Select  
**MENU > SCHEDULE > CANCEL TIMER**  
Press OK

Press LEFT, RIGHT, Down, Up to scroll to YES, press OK to delete the schedule.  
Press BACK to exit CANCEL TIMER.

If TIMER or WEEKLY SCHED. is on, the timer icon (🕒) or the weekly schedule icon (📅) will be displayed on the home page.

If the TIMER or WEEKLY SCHED. is cancelled, the icon will disappear from the home page.

**NOTE**

The TIMER / WEEKLY SCHED. must be reset if switching from WATER FLOW TEMP. to ROOM TEMP. or from ROOM TEMP. to WATER FLOW TEMP. Neither the TIMER or WEEKLY SCHED. are valid if the ROOM THERMOSTAT is on.

SCHEDULE				1/2
TIMER	WEEK. SCHED.	SCHED. CHECK	<b>CANCEL TIMER</b>	
CANCEL TIMER AND				
WEEKLY SCHEDULE?				
NO			YES	
OK CONFIRM				↕ ↗

01-01-2021 📅	9:00 🕒	🏠 13°
🌊 23 °C	ON ☀️	🚰 38 °C

01-01-2021 📅	9:00 🕒	🏠 13°
🌊 23 °C	ON ☀️	🚰 38 °C



---

**NOTE**

The ECO MODO function has the highest priority, followed in sequence by the TIMER or WEEKLY SCHED. functions and the DEFAULT TEMP. or CLIM.TEMP.SET. functions.

If ECO MODE is on, the DEFAULT TEMP. or CLIM.TEMP.SET. functions are disabled.

If ECO MODE is off, the DEFAULT TEMP. or CLIM.TEMP.SET. functions must be set again.

The TIMER or WEEKLY SCHED. functions are disabled when the unit operates in ECO MODE.

The TIMER or WEEKLY SCHED. functions can only operate if ECO MODE is off.

The TIMER and WEEKLY SCHED. functions have the same priority and the function that is set last takes precedence.

The DEFAULT TEMP. function is switched off if the TIMER or WEEKLY SCHED. functions are switched on. The CLIM.TEMP.SET. function is not affected when the TIMER or WEEKLY

SCHED. functions are set. WEEKLY WEEKLY

The DEFAULT TEMP. and CLIM.TEMP.SET. functions have the same priority and the function that is set last takes precedence.

---

**NOTE**

For all functions with an hourly schedule (DEFAULT TEMP., ECO, DISINFECT, DHW PUMP, TIMER, WEEKLY SCHED., SILENT MODE, HOLIDAY AT HOME), they can only be switched ON/OFF at the start and end times set.

---

## 9.17 Options

The Options menu includes the following functions:

- 1 SILENT MODE
- 2 HOLIDAY AWAY
- 3 HOLIDAY AT HOME
- 4 BACKUP HEATING

### 9.17.1 Silent mode

Silent Mode enables quieter operation of the unit. However, it also reduces the heating/cooling capacity of the system. There are 2 Silent Mode levels. Level 2 is quieter than level 1, and further reduces the heating or cooling capacity.

Silent Mode can be used in the following modes:

- continuous operation;
- start-up with timer. If

silent mode is on, the  icon appears on the home page.

Select

**MENU > OPTIONS > SILENT MODE**

Press OK

Press ON/OFF to set the current state ON or OFF.

Description:



If CURRENT STATE is OFF, SILENT MODE is disabled.



When SILENCE LEVEL is selected and OK or LEFT is pressed, the following page appears.

Press Down or Up to select level 1 or level 2.

Press OK.

OPTIONS				1/2
SILENT MODE	HOLIDAY AWAY	HOLIDAY AT HOME	BACKUP HEAT	
<b>CURRENT STATE</b>				OFF
SILENCE LEVEL				LEVEL 1
TIMER 1 START				12:00
TIMER 1 END				15:00
<b>ON/OFF</b> ON/OFF				



OPTIONS				
SILENT MODE	HOLIDAY AWAY	HOLIDAY AT HOME	BACKUP HEAT	
CURRENT STATE				OFF
SILENCE LEVEL				<b>LEVEL 1</b>
TIMER 1 START				12:00
TIMER 1 END				15:00
 EDIT				

OPTIONS				
SILENT MODE	HOLIDAY AWAY	HOLIDAY AT HOME	BACKUP HEAT	
CURRENT STATE				ON
SILENCE LEVEL				<b>LEVEL 2</b>
TIMER 1 START				12:00
TIMER 1 END				15:00
 EDIT				

If the TIMER function is selected, press OK to enter. 2 time slots can be set.

Scroll to ON and press OK to select or deselect.

If the two time slots are both deselected, SILENT MODE is always operational. Otherwise, it will be switched on according to the time schedule.

OPTIONS				2/2
SILENT MODE	HOLIDAY AWAY	HOLIDAY AT HOME	BACKUP HEAT	
TIMER 1				ON
TIMER 1 START				22:00
TIMER 1 END				07:00
TIMER 2				OFF
 EDIT				

## 9.17.2 Holiday Away

If the Holiday Away function is on, the  icon appears on the home page

This function prevents the system from freezing during winter holidays away from home and restarts the unit before returning home, while at the same time limiting consumption of the unit when not in use.

Select

**MENU > OPTIONS > HOLIDAY AWAY**

Press OK

Press ON/OFF to select OFF or ON and use LEFT, RIGHT, Down, Up to scroll and adjust the values. Example: suppose you want to go on a winter holiday. The current date is 31/01/2020 and you will leave on 02/02/2020, two days later.

- You will leave in 2 days and the house will be empty for 2 weeks.
- You want to reduce energy consumption and at the same time prevent your house from freezing.

Proceed as follows:

- 1) Configure the holiday with the settings below.
- 2) Switch Holiday mode on.

Select

**MENU > OPTIONS > HOLIDAY AWAY**

Press OK

Press ON/OFF to select OFF or ON and use LEFT, RIGHT, Down, Up to scroll and adjust the values.

Setting	Value
Holiday Away	ON
From	2 February 2020
To	16 February 2020
Operation mode	Heat
Disinfect	ON

### NOTE

If HOLIDAY AWAY mode is on and the DHW function is set to ON, the disinfect function cannot be switched on.

If HOLIDAY AWAY mode is on, the TIMER and WEEKLY SCHEDULE functions are disabled.

If CURRENT STATE is OFF, the HOLIDAY AWAY mode is OFF.

If CURRENT STATE is ON, the HOLIDAY AWAY mode is ON.



The remote control does not accept instructions when HOLIDAY AWAY mode is on.

If the DISINFECT function is on, the unit will be disinfected at 23:00 on the last day.

When HOLIDAY AWAY mode is on, the previously set climate curves are disabled and become operational again at the end of the scheduled period.

The preset temperature is invalid while HOLIDAY AWAY mode is on, but the value remains displayed on the home page.

OPTIONS				1/2
SILENT MODE	<b>HOLIDAY AWAY</b>	HOLIDAY AT HOME	BACKUP HEAT	
<b>CURRENT STATE</b>				ON
DHW MODE				OFF
DISINFECT				ON
HEAT MODE				ON
<b>ON/OFF</b> ON/OFF				

OPTIONS				2/2
SILENT MODE	<b>HOLIDAY AWAY</b>	HOLIDAY AT HOME	BACKUP HEAT	
<b>FROM</b>			02-02-2020	
TO			16-02-2020	
				 

## 9.17.3 Holiday at home

The HOLIDAY AT HOME function allows you to schedule up to 6 programmes without changing the normal schedule when spending your holidays at home.

During the holiday, the HOLIDAY AT HOME mode allows you to override the normal schedule without changing it.

Period	Schedule
Before and after the holiday	The normal schedule is applied.
During the holiday	The settings configured for the HOLIDAY AT HOME mode are used.

If HOLIDAY AT HOME mode is on,  icon appears on the the home page

Select

### MENU > OPTIONS > HOLIDAY AT HOME

Press OK

The following page appears

Select Holiday at home

Press Down.

Press ON/OFF to select OFF or ON.

If CURRENT STATE is OFF, the HOLIDAY AT HOME function is off.

If CURRENT STATE is ON, the HOLIDAY AT HOME function is on.

Press Down to adjust the date.

Press LEFT, RIGHT, Down, Up to scroll and adjust the values.

Press OK

Select Timer

Press OK twice

OPTIONS			
SILENT MODE	HOLIDAY AWAY	HOLIDAY AT HOME	BACKUP HEAT
CURRENT STATE			OFF
FROM		02-02-2020	
TO		16-02-2020	
TIMER			CONFIRM
ON/OFF		ON/OFF	

Press LEFT, RIGHT, Down, Up to scroll and press Down, Up to adjust the time, mode and temperature.

Scroll to n and press OK to select or deselect. (  Prg. selected.  Prg. deselected).

If you want to delete the schedule, move the cursor up and press OK,  changes to , the schedule is switched off.

OPTIONS						1/2
SILENT MODE	HOLIDAY AWAY	HOLIDAY AT HOME	BACKUP HEAT			
NO.	START	END	MODE	TEMP.		
1	<input type="checkbox"/>	00.00	00.00	HEAT	0°C	
2	<input type="checkbox"/>	00.00	00.00	HEAT	0°C	
3	<input type="checkbox"/>	00.00	00.00	HEAT	0°C	
						

OPTIONS						2/2
SILENT MODE	HOLIDAY AWAY	HOLIDAY AT HOME	BACKUP HEAT			
NO.	START	END	MODE	TEMP.		
4	<input type="checkbox"/>	00.00	00.00	HEAT	0°C	
5	<input type="checkbox"/>	00.00	00.00	HEAT	0°C	
6	<input type="checkbox"/>	00.00	00.00	HEAT	0°C	
						



If a start time is set later than the end time, or a temperature outside the allowed range is set for the chosen operation mode, the following page appears.

OPTIONS			
SILENT MODE	HOLIDAY AWAY	HOLIDAY AT HOME	BACKUP HEAT
Timer 1 not required The start time is the same as the end time.			
<b>OK</b> CONFIRM			

### NOTE

The HOLIDAY AWAY or HOLIDAY AT HOME functions must be set again if you change the unit's operation mode.

## 9.17.4 Backup heater

Available as an accessory or configuration The BACKUP HEATER function is used to force the backup heater on.

Select

**MENU > OPTIONS > BACKUP HEATER**

Press OK

If IBH and AHS are not enabled by the Dip-switches on the main hydraulic module control board, the following page appears.

IBH= indoor unit backup heater.

AHS= additional heating source.

OPTIONS			
SILENT MODE	HOLIDAY AWAY	HOLIDAY AT HOME	BACKUP HEAT
▶▶			

If IBH and AHS are enabled by the Dip-switches on the main hydraulic module control board, the following page appears Use ON/OFF to select ON or OFF.

### NOTE

If AUTO mode is on for room heating or cool-ing, the BACKUP HEATER cannot be selected The BACKUP HEATER function is invalid if only ROOM HEAT-ING MODE is enabled.

OPTIONS			
SILENT MODE	HOLIDAY AWAY	HOLIDAY AT HOME	BACKUP HEAT
<b>BACKUP HEATER</b>			ON
▶▶			
<b>ON/OFF</b> ON/OFF			

## 9.17.5 Child lock

The Child lock function prevents children from misusing the unit.

This function locks or unlocks selection of the operation mode and temperature control.

Select

**MENU > CHILD LOCK**

Enter the password.

CHILD LOCK	
Enter password :	
000	
<b>OK</b> CONFIRM	EDIT ▶▶



Press Down, Up to scroll and press ON/OFF to lock or unlock one or more operation modes.

The cooling/heating temperature cannot be adjusted when COOL/HEAT TEMP. ADJ. is locked.

If you want to adjust the cooling/heating temperature when it is locked, the following page appears.

The cooling/heating mode cannot be switched on or off when COOL/HEAT ON/OFF is locked. If you want to switch COOL/HEAT ON/OFF mode on or off when it is locked, the following page appears

The domestic hot water temperature cannot be adjusted when the DHW TEMP. ADJ. is locked. If you want to adjust the hot water temperature when DHW TEM. ADJ. is locked, the following page appears.

DHW mode cannot be switched on or off when DHW MODE ON/OFF is locked. If you want to switch DHW mode on or off when DHW MODE ON/OFF is locked, the following page appears.

CHILD LOCK	
COOL/HEAT TEMP. ADJ.	UNLOCK
COOL/HEAT MODE ON/OFF	UNLOCK
DHW TEMP. ADJ.	UNLOCK
DHW MODE ON/OFF	UNLOCK
UNLOCK LOCK/UNLOCK	

01-01-2021 9:00 13°

Cool/heat temperature adj. function locked. Unlock?

NO YES

OK CONFIRM

01-01-2021 9:00 13°

Cool/heat mode on/off function locked. Unlock?

NO YES

OK CONFIRM

01-01-2021 9:00 13°

DHW Temperature adj. function locked. Unlock?

NO YES

OK CONFIRM

01-01-2021 9:00 13°

DHW mode on/off function locked. Unlock?

NO YES

OK CONFIRM



Press OK to display the meaning of the error code.

**NOTE**

A total of eight error codes can be stored.

01-01-2021	9:00	↑13°
<p>E2 Communication error between the controller and the indoor unit</p> <p>Contact the serviceman.</p>		
<p><b>OK</b> CONFIRM</p>		

## 9.18.4 Parameters

The PARAMETERS function displays the main parameters, which are shown on two pages.

SERVICE INFORMATION			1/2
SERVICE	CODE ERROR	PARA-METERS	DISPLAY
ROOM TEMP. SET			26°C
MAIN TEMP. SET			55°C
TANK TEMP. SET			55°C
CURR. ROOM TEMP.			24°C

SERVICE INFORMATION			2/2
SERVICE	CODE ERROR	PARA-METERS	DISPLAY
CURR. MAIN TEMP.			26°C
CURR. TANK TEMP.			55°C
SMART GRID TIME			0 Hrs

## 9.18.5 Display

The DISPLAY function is used to set the interface

Press OK to open the function and press LEFT, RIGHT, Down, Up to scroll and adjust the values.

SERVICE INFORMATION			1/2
SERVICE	CODE ERROR	PARAMETERS	DISPLAY
TIME			9:00
DATE			01 - 01 - 2021
LANGUAGE			IT
BACKLIGHT			ON
OK CONFIRM			▶◀

SERVICE INFORMATION			2/2
SERVICE	CODE ERROR	PARAMETERS	DISPLAY
BUZZER			ON
SCREEN-LOCKING TIME			120 SEC
SMART GRID TIME			2 hours
ON/OFF ON/OFF			⬆

## 9.19 Operation parameters

Installer



The OPERATION PARAMETERS menu is used by the installer or the technician to check the operation parameters. The values shown on the pages are only indicative. On the home page, select

### MENU > OPERATION PARAMETERS

Press OK

The operation parameters are displayed on the following 9 pages.

Press Down, Up to scroll.

#### NOTE

The energy consumption parameter is calculated, not measured.

If a parameter is not available for the system, the corresponding value will be "--"

The heat pump capacity is indicative and should not be used as a measure of the unit's power.

The accuracy of the sensor is  $\pm 1^{\circ}\text{C}$ .

The flow-rate parameters are calculated according to the pump operation parameters, the deviation is different at different flow-rates, the maximum deviation is 15%.

OPERATION PARAMETERS	1/9
ONLINE UNITS NUMBER	0
OPERATION MODE	DHW
SV1 STATE	OFF
SV2 STATE	OFF
SV3 STATE	OFF
PUMP_I	OFF
↕	

OPERATION PARAMETERS	4/9
T5 DHW WATER TANK TEMP.	25°C
T 1B CIRCUIT2 WATER TEMP.	--°C
T1S C1 CLIM.CURVE TEMP.	0°C
T IS2 C2 CLIM. CURVE TEMP.	0°C
TW_0 PLATE W-OUTLET TEMP.	0°C
TW_I PLATE W-INLET TEMP.	0°C
↕	

OPERATION PARAMETERS	7/9
FAN SPEED	0 R/MIN
IDU TARGET FREQU.	0 Hz
FREQ.LIMITED TYPE	0
SUPPLY VOLTAGE	0V
DC GENERATRIX VOLTAGE	0V
DC GENERATRIX CURRENT	0A
↕	

OPERATION PARAMETERS	2/9
PUMP_0	OFF
PUMP_C	OFF
PUMP_S	OFF
PUMP_D	OFF
PIPE BACKUP HEATER	OFF
TANK BACKUP HEATER	OFF
↕	

OPERATION PARAMETERS	5/9
Tbt1 BUFFERTANK_UP TEMP.	0°C
Tbt2 BUFFERTANK_LOW TEMP.	0°C
Tsolar	0°C
SOFTWARE	IDU 00-00-2000V00
↕	

OPERATION PARAMETERS	8/9
T W_0 PLATE W-OUTLET TEMP.	0°C
TW_I PLATE W-INLET TEMP.	0°C
T2 PLATE F-OUT TEMP.	25°C
T2B PLATE F-IN TEMP.	--°C
T h COMP. SUCTION TEMP.	25°C
Tp COMP. DISCHARGE TEMP.	25°C
↕	

OPERATION PARAMETERS	3/9
GAS BOILER	OFF
T1 LEAVING WATER TEMP.	--°C
WATER FLOW	0.00M3/H
HEAT PUMP CAPACITY	0.00kW
POWER CONSUMPTION	0 kWh
Ta ROOM TEMP.	--°C
↕	

OPERATION PARAMETERS	6/9
ODU MOD.	0 kW
COMP.CURRENT	0 A
COMP.FREQUENCY	0 Hz
COMP. RUN TIME	0 MIN
COMP. TOTAL RUN TIME	0 HOURS
EXPANS.VALVE OPENING	0 P
↕	

OPERATION PARAMETERS	9/9
T3 COIL F. TEMP.	25°C
T3 OUTDOOR AIR TEMP.	25°C
TF MODULE TEMP.	0°C
P1 COMP. PRESS.	0 kPa
ODU SOFTWARE	00-00-2000V00
HMI SOFTWARE	24-02-2021V67
↕	

## 10. MODBUS registers

### 10.1 Controls

#### Modbus

register	Meaning	Description	
0	ON/OFF	bit15	Reserved
		bit14	Reserved
		bit13	Reserved
		bit12	Reserved
		bit11	Reserved
		bit10	Reserved
		bit9	Reserved
		bit8	Reserved
		bit7	Reserved
		bit6	Reserved
		bit5	Reserved
		bit4	Reserved
		bit3	0= off (T2S); 1= on (T2S) (WATER FLOW TEMP control - zone 2)
		bit2	0= DHW (T5S) off; 1= DHW (T5S) on
		bit1	0= off (T1S); 1= on (T1S) (WATER FLOW TEMP control - zone 1)
bit0	0= off (TS) 1= on (TS) (ROOM TEMP thermostat control)		
1	Operation mode	1: auto; 2: Cooling ; 3: heating ; other value: invalid	
2	Set water temp. T1s	bit8-bit15	Water temp. T1s setting for ZONE 2
		bit0-bit7	Water temp. T1s setting for ZONE 1
3	Set air temperature Ts	Room temperature setting, when a valid Ta is present, 17°C ~ 30°C transmission value equal to actual value * 2; 35 is transmitted,	
4	T5s	Storage tank water temperature setting, 20°C ~ 60/75°C (EDGE A with AHS can be set at 75°C, other unit at 60°C) Default =50°C	



Address register	Meaning	Description	
5	Function settings	bit15	Reserved
		bit14	Reserved
		bit13	1 = ZONE 2 curve on; 0 = ZONE 2 curve disabled
		bit12	1 = ZONE 1 curve on; 0 = ZONE 1 curve disabled
		bit11	DHW pump operating with return water at constant temperature
		bit10	ECO mode
		bit9	Reserved
		bit8	Holiday at home (read only, cannot be changed)
		bit7	0= silent level1; 1= silent level2
		bit6	Silent mode
		bit5	Going on holiday (read only, cannot be changed)
		bit4	Sterilisation (disinfection)
		bit3	Reserved
		bit2	Reserved
		bit1	Reserved
bit0	Reserved		
6	Curve selection	bit8-bit15	ZONE 2 Curves 1- 9
		bit0-bit7	ZONE 1 Curves 1- 9
7	Forced hot water	0 invalid	TBH is the electric heater inside the storage tank, IBH is the heating backup electric heater TBH and IBH cannot be forced together
8	Forced TBH	1 forced ON	
9	Forced IBH	2 forced OFF	
10	SG operation time	0-24hrs	
11	Set the water temperature T1s zone1	Water temperature T1s setting for ZONE 1	
12	Set the water temperature T1s zone2	Water temperature T1s setting for ZONE 2	

## 10.2 States

Address register	Meaning	Description
100	Operating frequency	Compressor operating frequency in Hz. Value read = current value
101	Operation mode	Unit's operation mode, 0: shut down 2: cooling, 3: heating,
102	Fan speed	Fan speed, unit: rpm. Value read = current speed
103	PMV	ODU electronic expansion valve opening, unit: P. Value read = current value (shows only 8 multiples. Only multiples of 8 will be shown)
104	Entering water temperature	TW_in, unit:°C; value read = current value
105	Leaving water temperature	TW_out, unit:°C; value read = current value
106	T3 temperature	Condenser temperature in °C. Value read = current
107	T4 temperature	Outdoor temperature, unit: °C. Value read = current value
108	Discharge gas temperature	Compressor discharge temperature Tp, unit: °C. Value read = current value
109	Intake gas temperature	Compressor suction temperature Th, unit: °C. Value read = current value
110	T1	Leaving water temperature, unit: °C. Value read = current value
111	T1B	Leaving water temperature (after additional heat source), unit: °C. Value read = current value
112	T2	Liquid refrigerant temperature, unit: °C. Value read = current value
113	T2B	Gas refrigerant temperature, unit: °C. Value read = current value
114	Ta	Outdoor temperature, unit: °C value, read = current value
115	T5	Storage tank water temperature
116	Pressure value 1	ODU high pressure value, unit: kPa. Value read = current value
117	Pressure value 2	ODU high pressure value, unit: kPa. Value read = current value
118	ODU current	Current ODU value, unit: A, Value read = current value
119	ODU voltage	ODU voltage value, unit: V. Value read = current value (reserved)
120	Tbt1	Tbt1 unit: °C. Value read = current value
121	Tbt2	Tbt2 unit: °C. Value read = current value
122	Compressor running time	Compressor running time, unit: hour, value read = current value
123	Unit	Register 200 is reserved for type 0702 and the value for type 071X represents the capacity of type 4-30 represents 4-30KW



Address register	Meaning	Description	
124	Error code	Specific error code, refer to the code table.	
125	Error code 2		
126	Error code 2		
127	Error code 3		
128	Status bit: 1	BIT15	Ask for installation parameter, 1: ask; 0: don't ask
		BIT14	Load software version, 1: ask; 0: don't ask
		BIT13	Load SN, 1: ask; 0: don't ask
		BIT12	Reserved
		BIT11	EVU 1: electricity (from photovoltaics) 0: based on SG signal
		BIT10	SG 1: normal electric price 0: high electric price
		BIT9	Storage tank water antifreeze
		BIT8	Solar signal input
		BIT7	Room thermostat in cooling mode
		BIT6	Room thermostat in heating mode
		BIT5	ODU test mode
		BIT4	Remote ON/OFF (1 : d8)
		BIT3	Oil return
		BIT2	Antifreeze
		BIT1	Defrosting
BIT0	Recirculation pump		
129	Load output	BIT15	Defrosting
		BIT14	External heat source
		BIT13	Compressor on
		BIT12	ALARM
		BIT11	Solar pump Pump_S
		BIT10	HEAT4
		BIT9	SV3
		BIT8	Mixing pump P_c
		BIT7	Recirculation pump P_d
		BIT6	External pump P_o
		BIT5	SV2
		BIT4	SV1
		BIT3	Standard unit pump Pump_l
		BIT2	TBH
		BIT1	IBH2
BIT0	IBH		
130	IDU software version	0 - 99 Indicates the software version of the indoor unit	
131	HMI software version	0 - 99 Indicates the software version of the user interface	
132	Unit target frequency	Compressor target frequency in Hz. Send value = actual value	
133	DC bus current	Unit: Amps	
134	DC bus voltage	Return value = actual value / 10 (Unit: Volts)	
135	TF module temperature	Unit (°C) - External feedback to unit	
136	Curve 1T1S	Value read = current value	
137	Curve 2T1S	Value read = current value	



Address register	Meaning	Description
138	Water flow	Value read = current value* 100 [unit: m <sup>3</sup> /hour]
139	ODU frequency limitation	Diagram value ----- ODU feedback 174
140	IDU capacity	Value read = current value* 100 unit: kW
141	Solar T	
142	Number of units in cascade	BIT1-BIT15 represents the online/offline state of 1-1 5 units BIT0 Reserved
143	High bit of electrical	Energy consumption
144	Low bit of electrical	
145	High bit of heat	Heating capacity of the system
146	Low bit of heat	
147	AHS power supply output to EDGE series	Value read = current value* 10 (unit: V)

### 10.3 States of units in cascade

Address register	Meaning	Description	
1000	Operation mode	Operation mode, 2: cool, 3: heat; 0: OFF	
1001	Comp. Frequ.	Comp.freq., unit: Hz, (value read = current value)	
1002	Twi	TW_in, unit:°C entering water temperature; (value read = current value)	
1003	Two	TW_out, unit:°C leaving water temperature; (value read = current value)	
1004	Tsolar	Tsolar, unit:°C solar temperature; (value read = current value)	
1005	Save unit error code	Specific error code, refer to the code table.	
1006	P6 error	Reserved	
1007	IDU state 1	Bit3~7	Reserved
		Bit2	Oil return
		Bit1	Antifreeze
		Bit0	Defrosting
1008	IDU status 2		Reserved
			Reserved
			Reserved
			Reserved
		Bit4	T1 leaving water temperature; 1- enabled; 0- disabled
		Bit3	IBH backup system electric heater; 1- enabled; 0- disabled
		Bit2	DHW
		Bit1	Heat
1009	IDU load	Bit7	HEAT 4 compressor heater 1- on; 0- off
			Reserved
		Bit5	Defrosting 1- on; 0- off
		Bit4	RUN 1- on; 0- off
		Bit3	PUMP_I 1- on; 0- off
			Reserved
		Bit1	IBH2 = 1- on; 0- off
Bit0	IBH1 = 1- on; 0- off		
1010	IDU load output - Reserved		Reserved
			Reserved
			Reserved
			Reserved
			Reserved
			Reserved
			Reserved
			Reserved
1011	T1	Total leaving water, unit:°C, (value read = current value);invalid: 0x7F	
1012	T1B	Total leaving water (after additional heat source), unit:°C. (value read = current value); invalid: 0x7F	
1013	T2	Refrigerant liquid temperature, unit:°C. (value read = current value); invalid: 0x7F	
1014	T2B	Refrigerant gas temperature, unit:°C. (value read = current value); invalid: 0x7F	
1015	T5	Storage tank temperature, unit:°C. (value read = current value); invalid: 0x7F	
1016	Ta	Indoor air temperature, unit:°C. (value read = current value); invalid: 0x7F	
1017	Tbt1	Inertial storage tank temperature, unit:°C. (value read = current value); invalid: 0x7F	
1018	Tbt2	Additional storage tank temperature, unit:°C. (value read = current value); invalid: 0x7F	



Address register	Meaning	Description
1019	Water flow	(value read = current value)* 100, unit: M3/H
1020	Unit type	10-18 : means 10-18KW
1021	Unit target frequency	
1022	Software version	1~99 means IDU software version
1023	High bit of capacity	
1024	Low bit of capacity	
1025	IDU capacity	(value read = current value) *100, unit: KW
1026	Fan rpm	Fan speed, (value read = current value)
1027	PMV	ODU EXV opening, unit: Pulse. R & It (value read = current value) (shows only 8 multiples. Only multiples of 8 will be shown)
1028	T3	Coil temperature, unit: °C
1029	T4	Outdoor temperature, unit:°C
1030	Tp	Discharge temperature Tp, unit: °C
1031	Th	Suction temperature, unit:°C
1032	TF	Unit (°C) ---- External unit feedback invalid value 0x7F
1033	Pressure 1	ODU high pressure, unit: kPA. (value read = current value)
1034	Pressure 2	ODU low pressure, unit: kPA. (value read = current value) (reserved)
1035	DC bus current	Unit: amps
1036	DC bus voltage	(value read = current value) (unit:V)
1037	ODU current	Operating power supply, unit: A (value read = current value)
1038	ODU voltage	Unit voltage: V (value read = current value)
1039	ODU frequency limitation	Solution read from ODU 174
1040	High bit of electrical computation	
1041	Low bit of electrical computation	
1042	ODU software version	

## 10.4 Alarms

In the event of malfunctions, alarms are indicated by the appearance of the “Active alarm” symbol on the multifunction keypad.

To view the alarms select Menu ► Service information

To reset an alarm, remove the cause of the alarm and reset the active alarm. Before resetting an alarm, identify and remove the cause of the alarm.

Repeated resets can lead to irreversible damage such as malfunction of the system itself. If in doubt, contact a service centre.

Error code	Description	Modbus Code
E0	Water flow failure (water flow failure 3 times)	1
E1	Line-to-line or zero phase error (three-phase models have this error code)	33
E2	Communication error between user interface and hydraulic module	2
E3	Leaving water temperature sensor T1 failure	4
E4	Storage tank water temperature sensor T5 failure	5
E5	Unit temperature sensor T3 failure	39
E6	Unit room temperature sensor T4 failure	40
E7	Inertial storage tank sensor Tbt1 failure	6
E8	Water flow failure (displayed three times and can be reset after minutes)	9
E9	Temperature sensor Th failure	41
EA	Unit air temperature sensor Tp failure	42
Eb	Tsolar sensor failure	7
EC	DHW additional storage tank sensor Tbt2 failure	8
Ed	Water temperature sensor Twin board replacement failure	10
EE	EEPROM hydraulic module failure	11
P0	Low pressure protection	50
P1	Discharge temperature/high pressure control switch protection	52
P3	Compressor overcurrent protection	53
P4	Exhaust air temperature overheating protection Tp	54
P5	Twin-Twout, Twout-Twin protection or water supply temperature too high	25
P6	Module protection (IPDU and IR341)	55
Pb	Antifreeze (this is not a protection, the alarm light does not flash), the remote control does not display Pb, but displays the antifreeze icon;	25
Pd	Unit T3 over-temperature protection	57
PP	Abnormal temperature difference between entering and leaving water	31
H0	Communication error between indoor unit and unit (continuous communication error for 10 seconds)	3
H0	Communication error between unit and indoor unit (no communication in 10 s)	38
H1	Communication error between unit and IR341 (unit and inverter module)	39
H2	Gas side refrigerant temperature sensor T2 failure	12
H3	Liquid side refrigerant temperature sensor T2B failure	13
H4	After 3 L signals (L0/L1) in 1 hour, H4 appears, which cannot be reset. After H4 it is possible to check the last 3 L signals (not only L0, L1). For example: L0-L4-L8-L9-L0-L1 signalling in 1 hour, H4 fault signalling. The faults to be checked are L9, L0, L1.	44
H5	Temperature sensor Ta failure	15
H6	DC fan failure	45
H7	Abnormal power supply voltage	46
H8	High pressure sensor failure	47
H9	Sensor Tw2 failure	20
HA	Plate exchanger outlet temperature sensor failure	14
Hb	Three consecutive faults PP protection and Twout < 7°C; reset for power failure;	21



Error code	Description	Modbus Code
Hd	Communication error between slave and master (this error occurs when several units are connected in parallel)	24
HE	Communication error between hydraulic module and hydraulic module adapter board	23
HF	Unit EEPROM failure	43
HH	H6 failure 10 consecutive times in 120 minutes (reset after shut down)	48
HP	Cooling mode low pressure protection (in 1 hour, low pressure is below 0.6 MPa three consecutive times, can be reset automatically)	49
C7	Heat sink over-temperature protection	65
bH	PED board failure	143
F1	DC bus low voltage protection	142
L0	DC compressor module error	112
L1	DC bus low voltage protection	116
L2	DC bus high voltage protection	134
L4	MC/synchronisation/closed circuit error	135
L5	Zero speed protection	136
L7	Phase sequence error protection	138
L8	Protection for when the preceding and following speed variation is >15 Hz	139
L9	Protection for when the difference between the set speed and the operating speed is >15 Hz	141
C0	multiple units configured as Master in the M/S network.	58

## 10.5 Password-protected unit parameters

Installer



The unit leaves the factory with the unit parameters set by default to values capable of fulfilling most installation situations. For detailed customisation of the system, however, it is possible to make changes; a list of all the unit parameters, with the available settings, is given below. Depending on the configuration of the unit, some parameters are visible and others are not.

### a CAUTION

Access to parameters or modifications are only allowed to a qualified serviceman who assumes all responsibility, in case of doubt contact Bosch. For any changes not permitted or not approved by Bosch, Bosch declines any responsibility for malfunctions and/or damage to the unit/system and to people

Address register	Meaning	Description
200	Type of Unit	reserved, factory data
201	T1S Upper temperature limit set in cooling mode	The 8 low bits represent zone 1 and the 8 high bits represent zone 2 The 8 low bits represent area 1 and the 8 high bits represent area 2
202	T1S Lower temperature limit set in cooling mode	The 8 low bits represent zone 1 and the 8 high bits represent zone 2 The 8 low bits represent area 1 and the 8 high bits represent area 2
203	T1S Upper temperature limit set in heating mode	The 8 low bits represent zone 1 and the 8 high bits represent zone 2 The 8 low bits represent area 1 and the 8 high bits represent area 2
204	T1S Lower temperature limit set in heating mode	The 8 low bits represent zone 1 and the 8 high bits represent zone 2 The 8 low bits represent area 1 and the 8 high bits represent area 2
205	TS Set the upper temperature limit	Reading = actual*2 actual value *2
206	TS Set the lower temperature limit	Reading = actual*2 actual value *2
207	DHW upper temperature limit	
208	DHW lower temperature limit	
209	Recirculation pump operating time	Recirculation pump, default operating time 5 minutes, adjustment range 5 - 120 min, with steps of 1 min



Address register	Meaning	Description	
210	Parameter setting 1	BIT15	DHW enabling/disabling
		BIT14	Storage tank water electric heater TBH (read only)
		BIT13	Disinfect function
		BIT12	DHW pump; 1=enabled ; 0=disabled
		BIT11	Reserved
		BIT10	The DHW pump supports pipe disinfection
		BIT9	Cooling mode enabling
		BIT8	T1S cooling mode high/low temperature control (read only) zone 1
		BIT7	Heating mode enabling
		BIT6	T1S heating mode high/low temperature control (read only) zone 1
		BIT5	Backup PUMPI silent pump function, 1:backup
		BIT4	Backup room temperature sensor Ta
		BIT3	Room thermostat (Room thermostat)
		BIT2	Room thermostat - MODE SETTING
		BIT1	Double room thermostat, 1=enabled; 0=disabled
BIT0	0: Room cooling and heating priority; 1: Hot water priority		
210	Parameter setting 2	BIT15	DHW (double DHW double enabling) 1: Yes 0: No
		BIT14	DHW control M1M2 potential-free contact 1: Yes 0: No
		BIT13	RT_Ta_PCNE (Enable small temperature board)
		BIT12	Sensor Tbt2 enabling 1: Yes 0: No
		BIT11	Selection of pipe length 1:> 10 m 0: <10 m
		BIT10	Solar input port 1: CN18 0: CN11
		BIT9	Solar module 1: Yes 0: No
		BIT8	Definition of the input port: 0= remote switch 1= DHW heater
		BIT7	Smart grid: 0= None 1= Yes
		BIT6	T1B Sensor enabling 0= None 1= Yes
		BIT5	T1S High/low cooling temp. setting zone 2
		BIT4	T1S High/low heating temp. setting zone 2
		BIT3	Double zone setting is effective
		BIT2	Ta Sensor position 1: IDU 0: HMI
BIT1	Tbt Sensor enabling 1: Yes 0: No		
BIT0	IBH / AHS Installation position 1: storage tank 0: piping		
212	dT5_On	A Series: Default: 10°C range: 1 ~ 30°C E series: Default: 5°C, range: 2 ~ 0°C control range 1°C	
213	dT1S5	Default: 10°C, range: 5-40°C, Control range 1°C	
214	T_Interval_DHW	Default: 5min, interval: 5~5min, Control interval 1min	
215	T4DHWmax	Default: 43°C, range: 35-43°C, Control range 1°C	
216	T4DHWmin	A Series: Default: -10°C range: -25 ~ 30°C E series: Default: -10°C, range: -25-5°C control range 1°C	
217	t_TBH_delay	Default: 30min interval: 0~240min, Control interval 5min	
218	dT5S_TBH_off	Default: 5°C, range: 0~10°C, Control range 1°C	
219	T4_TBH_on	A Series: Default: 5°C range: -5 ~ 50°C E series: Default: 5°C, range: 5 ~ 20°C control range 1°C	



Address register	Meaning	Description
220	T5s_DI	Storage tank water temp. setting for disinfect function. Default: 65°C, Control range : 60~70°C
222	t_DI_hightemp	High temperature disinfect time. Default: 15min; Control interval 5~60min
223	t_interval_C	Compressor start time interval in cooling mode. Default value 5min; interval: 5 ~ 5min
224	dT1SC	Default: 5°C, range: 2-10°C, Control range 1°C
225	dTSC	Default:2°C, range:1-10°C, Control range 1°C
226	T4cmax	Default: 52°C, range: 35-52°C, Control range 1°C
227	T4cmin	Default: -5°C, range: -5-25°C, Control range 1°C
228	t_interval_H	Compressor start time interval in heating mode. Default value 5min; interval: 5 ~ 5min
229	dT1SH	A Series: Default: 5°C range: 2-20°C E series: Default: 5°C, range: 2-10°C control range 1°C
230	dTSH	Default: 2°C, range: 1-10 °C, Control range 1°C
231	T4hmax	Default: 25°C, range: 20-35°C, Control range 1°C
232	T4hmin	A Series: Default: -1.5°C range: -25-30°C control range 1°C E Series: Default: -1.5°C, range: -25-15°C control range 1°C
233	T4_IBH_on	Outdoor temperature for starting the backup heater IBH. Default value: -5 °C; control range: -15 ~ 10 °C.
234	dT1_IBH_on	IBH indoor unit backup electric heater switch-on temperature hysteresis, setting range: 2~10°C, default value is 5°C
235	t_IBH_delay	Compressor operation time before starting the backup heater. Default value 30min; control range: 15 ~ 120min
236	t_IBH12_delay	Reserved
237	T4_AHS_on	Room temperature for starting the additional heating source AHS. A series: range: -15 ~ 30°C E series: control range -15 ~ 10 °C model default value is 10°C, or -5°C
238	dT1_AHS_on	The temperature difference for starting the additional heating source AHS. A Series: Default value 5°C; range: 2 ~ 20°C E series: Default value 5°C; control range: 2 ~ 10°C
239	dT1_AHS_off	Reserved
240	t_AHS_delay	Compressor operation time before starting the additional heating source. Default value 30min; control range 5 ~ 120min.
241	t_DHWHP_max	Maximum operating time for the heat pump to run hot water. Default value: 90min; control range: 10 ~ 600 min; Set value in
242	t_DHWHP_restrict	Maximum operating time of the heat pump in heating/cooling mode. Default value: 30min; control setting: 10 ~ 600 min; Set value in minutes
243	T4autocmin	Default value: 25°C, range: 20~29°C, Control range 1°C
244	T4autohmax	Default value:17°C, range: 10~17°C, Control range 1°C
245	T1S_H.A_H	T1 value in heating mode during holidays; Default 25°C; Control range : 20~25°C.
246	T5S_H.A_DHW	T5 value in hot water mode during holidays Default 25°C; Control range : 20~25°C.
247	Start percentage	Default value 10; range 10-100, Control range 10
248	Adjustment time	Default value 5; Interval 1-60
249	dTbt2	Default value 15; range 0-50
250	IBH1 power	Default value 0; range 0-200; unit 100W
251	IBH2 power	Default value 0; range 0-200; unit 100W
252	TBH power	Default value 0; range 0-200; unit 100W
253	Comfort parameter	Reserved, query this register to report address errors
254	Comfort parameter	Reserved, query this register to report address errors



Address register	Meaning	Description
255	t_DRYUP	Heating days; Default 8 days; Control interval: 4 ~15 days
256	t_HIGHPEAK	Floor drying days. Default 5 days, Control interval: 3 ~ 7 days
257	t_DRYD	Cooling days. Default 5 days. Control interval: 4~ 15 days
258	T_DRYPEAK	Max floor drying temperature. Default 45°C; Control range: 30-55°C
259	t_firstFH	Time of first floor Default heating. value 72 hours; control interval 48-96 hours
260	T1S(First warm)	Leaving water temperature for preheating radiant panels. Default: 25°C; Control range 25~35°C
261	T1SetC1	Temperature curve parameters in cooling mode 9, Range setting 5-25°C, default 10°C
262	T1SetC2	Temperature curve parameters in cooling mode 9, Range setting 5-25°C, default 16°C
263	T4C1	Temperature curve parameters in cooling mode 9, Range setting (-5)-46°C, default 35°C
264	T4C2	Temperature curve parameters in cooling mode 9, Range setting (-5)-46°C, default 25°C
265	T1SetH1	Temperature curve parameters in heating mode 9, Range setting 25-60°C, default 35°C
266	T1SetH1	Temperature curve parameters in heating mode, Range setting 25-60°C, default 28°C
267	T4H1	Temperature curve parameters in heating mode, Range setting (-25)-35°C, default -5°C
268	T4H2	Temperature curve parameters in heating mode, Range setting (-25)-35°C, default -7°C
269		Current limitation scheme, 0= no setting; 1~8= Scheme 1~8, predefined 0
270	HB: t_T4_FRESH_C	Interval setting 0.5 - 6 hours, send value = current value * 2
	LB: t_T4_FRESH_H	Interval setting 0.5 - 6 hours, send value = current value * 2
271	T_PUMPI_DELAY	Interval setting 2-20, send value = current value * 2
272	EMISSION TYPE	Bit12-15= Zone 2 Type of cooling terminal
		Bit8-11= Zone 1 Type of cooling terminal
		Bit4-7= Zone 2 Type of heating terminal
		Bit0-3= Zone 1 Type of heating terminal

# 11. Serviceman Warnings



## FLAMMABLE MATERIAL

The refrigerant used inside this unit is flammable. A refrigerant leak that is exposed to an external ignition source can create fire risks.

## 11.1 Controls in the area

Before starting work on a system containing flammable refrigerants, carry out the appropriate safety checks to ensure that the risk of ignition is minimal. When repairing the refrigerant system, it is recommended that the following precautions be taken before starting the work.

## 11.2 Work procedures

The work must be carried out according to a controlled procedure in order to minimise the risk of flammable gases or vapours being present during the work.

## 11.3 General work area

Maintenance personnel and other people working in the area should be informed about the nature of the work to be done. It is recommended not to carry out operations in enclosed spaces. The area around the workspace must be made inaccessible. Verify that conditions within the area are safe in terms of control of flammable materials.

## 11.4 Checking the presence of refrigerant

The area must be checked using an appropriate refrigerant detector before and during the intervention so that the technician is aware of potentially flammable atmospheres. Ensure that the leak detection equipment is suitable for use with flammable refrigerants (does not generate sparks and is properly sealed or intrinsically safe) and is located in a suitable space for early detection of leaks in relation to the maintenance work carried out.



### NOTE

Please note that R-32 refrigerant is heavier than air.

## 11.5 Presence of fire extinguishers

If hot operations are to be carried out on refrigeration equipment or associated components, a suitable fire extinguisher must be kept on hand. Keep a dry-powder or CO<sub>2</sub> extinguisher near the loading area.

## 11.6 Absence of ignition sources

When the operations to be carried out on a refrigeration system involve exposing piping containing or having contained a flammable refrigerant, it is forbidden to use any source of ignition that could generate a risk of fire or explosion. All possible sources of ignition, including cigarette smoke, should be kept at a sufficient distance from the installation, repair, disassembly and disposal site, as flammable refrigerant may escape into the surrounding space during these operations. Before starting the work, the area around the appliance must be inspected to ensure that it does not present ignition or flammability hazards. "NO SMOKING" signs must be affixed.



## 11.7 Area ventilation

---

Before working on the system or performing hot operations, make sure the area is open or adequately ventilated. Ventilation must be constant for the entire duration of the operation. Ventilation must be capable of safely dispersing all refrigerant released and preferably expelling it outside into the atmosphere.

## 11.8 Controls on refrigeration equipment

---

When changing an electrical component, the new one must be suitable for the intended use and meet the correct specifications. The manufacturer's maintenance and serviceman instructions must be followed in all circumstances. When in doubt, consult the manufacturer's technical department. The following checks are recommended for installations using flammable refrigerants:

- the charge volume must be suitable for the room volume and the intended use in which the components containing the refrigerant are installed, see installation requirements in EN 378;
- ventilation devices and openings must open properly and not be obstructed;
- if an indirect refrigerant circuit is used, the presence of refrigerant in the secondary circuits must be checked; the equipment markings must remain visible and legible;
- markings and indications that become illegible shall be corrected;
- pipes or other components of the refrigerant circuit shall be installed in locations where exposure to potentially corrosive substances is unlikely for components containing the refrigerant, unless they are made of materials inherently resistant to corrosion or adequately protected against the risk of corrosion.

## 11.9 Controls on electrical devices

---

The repair and maintenance procedures for electric components must include initial safety checks and component inspection procedures. If a defect is found that may generate safety risks, the power supply to the circuit must be interrupted until the problem is satisfactorily resolved. If the problem cannot be solved immediately, but it is necessary to keep the system running, an appropriate temporary solution must be adopted. The situation should be communicated to the owner of the equipment so that all persons concerned can be duly informed.

Initial safety checks:
<ul style="list-style-type: none"><li>• check that the condensers are discharged: this procedure must be performed safely to avoid the possibility of sparks;</li><li>• check that there are no live components or wires exposed while charging, restoring or venting the system;</li><li>• check for interruptions in the earthing;</li><li>• check that the unit is not powered and if necessary disconnect the power supply before proceeding with the next steps.</li></ul>



## 11.10 Repair of sealed components

---

While repairing sealed components, all electrical utilities must be disconnected from the equipment before removing the sealing covers, etc. If it is absolutely necessary to have electrical power supply during the intervention, a permanent leakage detection method must be set up at the most critical point that can signal any potentially dangerous situations.

Particular attention must be paid to the following aspects to ensure that, when working on electrical components, the casing is not altered to such an extent that the required level of protection is compromised, including damage to cables, excessive number of connections, use of terminals that do not conform to original specifications, damage to seals, incorrect assembly of glands, etc.

- Check that the device is securely mounted.
- Check that the seals or sealing materials have not deteriorated to such an extent that they no longer guarantee a perfect seal keeping flammable atmospheres from entering. Spare parts must comply with the manufacturer's specifications.

**NOTE**

the use of silicone sealants may make some types of leak detection equipment less effective.

## 11.11 Reparation of intrinsically safe components

---

Before applying capacitance or permanent inductance loads to the circuit, check that this operation does not result in the permissible voltage and current values for the equipment in use being exceeded. Intrinsically safe components are the only types of components that can be operated under voltage in the presence of a flammable atmosphere. The test device shall have the correct nominal characteristics. For component replacement use only the parts specified by the manufacturer. Other components may cause ignition of re-frigerant released into the atmosphere.

## 11.12 Wiring

---

Check that the wiring is not exposed to wear, corrosion, excessive pressure, vibration, sharp edges or other adverse environmental influences. The control should also take into account the effects of ageing or continuous vibration from compressors, fans or other similar sources.

## 11.13 Detection of flammable refrigerants

---

The use of potential ignition sources for the search or detection of refrigerant leaks is prohibited under any circumstances. The use of halogen torches (or other open flame detection systems) is not permitted.

## 11.14 Leak detection methods

---

The following leak detection methods are considered acceptable for systems containing flammable refrigerants. Electronic leak detectors can be used to detect flammable refrigerants, but their sensitivity may not be adequate or require recalibration. (Detection equipment must be calibrated in a refrigerant-free area.) Check that the detector is not a potential ignition source and is suitable for the refrigerant. Leak detection equipment must be configured at a percentage of the lower flammability limit (LFL) of the refrigerant and be calibrated for the refrigerant used with confirmation of the appropriate gas percentage (max. 25%). Leak detection fluids are suitable for use with most refrigerants but the use of chlorine containing detergents should be avoided, as chlorine can react with the refrigerant and corrode copper piping.

If a leak is suspected, it is recommended to remove or extinguish all open flames. If there is a refrigerant leak requiring brazing, all refrigerant must be removed from the system, or isolated (by means of shut-off valves) in a part of the system away from the leak. The system should then be purged with oxygen-free nitrogen (OFN) both before and during brazing.

## 11.15 Removal and evacuation

---

When the refrigerant circuit needs to be repaired or for other purposes, conventional procedures can be followed. However, it is important to follow recommended practices taking flammability hazards into account. The following procedure is recommended:

- extract the refrigerant;
- purge the circuit with inert gas;
- evacuate;
- purge again using inert gas;
- open the circuit by cutting or brazing.

The refrigerant charge can be recovered in the appropriate cylinders. The system must be purged with oxygen-free nitrogen to make the unit safe. It may be necessary to repeat this procedure several times. Do not use compressed air or oxygen for this operation.

Purging can be performed by introducing oxygen-free nitrogen into the vacuum circuit in the system and continuing to fill until operating pressure is reached, then venting into the atmosphere and recreating the vacuum. This procedure must be repeated until the refrigerant is completely removed from the system. When the last OFN charge is introduced, the system must be vented to atmospheric pressure to allow work to be performed. This operation is absolutely essential if brazing operations are to be carried out on the piping.

Check that the output for the vacuum pump is not closed for any ignition source and that good ventilation is available.

## 11.16 Charging operations

---

In addition to conventional charging procedures, it is recommended to follow the ensuing guidelines:

- When using charging equipment, avoid contamination with different refrigerants.
- Cylinders must be held vertically.
- Before charging the refrigerant into the system, make sure that it is properly earthed.
- Label the system after loading (if the label is not already present).
- Use extreme care to avoid overfilling or underfilling the system.
- Before recharging the system, test the pressure using oxygen-free nitrogen. After charging, but before start-up, check the system for leaks. Perform an additional leakage check before leaving the site.

## 11.17 Disposal

---

Before performing this procedure, it is essential that the technician is fully familiar with the equipment and all of its components. It is recommended to recover all refrigerants following safe procedures. Before proceeding, take an oil and refrigerant sample.

Before reusing the recovered refrigerant, it should be analysed if necessary. Before starting the procedure it is essential to check the availability of the power supply.

- Familiarise yourself with the device and its operation.
- Electrically isolate the system.
- Before proceeding, check the following:
  - that mechanical equipment for handling refrigerant cylinders is available if necessary;
  - that the necessary personal protective equipment is available and is used;
  - that the recovery process is carried out under the constant supervision of a competent person;
  - that the recovery equipment and cylinders comply with regulations in force.
- If possible, transfer the refrigerant to the unit using a “pump-down” procedure.
- If it is not possible to create a vacuum, use a manifold that allows the refrigerant to be expelled from various parts of the system.
- Before proceeding with the recovery, place the cylinder on the scales.
- Start the recovery device and use it according to the manufacturer's instructions.
- Do not fill the cylinders excessively. (Do not exceed 80% of the liquid volume).
- Do not exceed the maximum working pressure of the cylinder, even temporarily.
- After filling the cylinders correctly and completing the procedure, transfer the cylinders and equipment from the site as soon as possible and close all isolation valves on the equipment.
- Before loading the recovered refrigerant into another refrigeration system it will be necessary to clean

and check it.

## 11.18 Labelling

---

The appliance must be labelled to indicate that it has been decommissioned and emptied of refrigerant. The label must be dated and signed. Make sure that labels indicating flammable refrigerant content are affixed to the appliance.

## 11.19 Recovery

---

- When discharging refrigerant from a system for maintenance or decommissioning reasons, it is recommended to extract the refrigerant safely.
- If the refrigerant is decanted into cylinders, use only cylinders suitable for refrigerant recovery. Verify that the number of cylinders required to hold the entire system charge is available. All cylinders to be used shall be designated for the refrigerant recovered and labelled for that refrigerant (special refrigerant re-recovery cylinders). Cylinders shall be equipped with a pressure relief valve and well-functioning shut-off valves.
- Empty recovery cylinders must be evacuated and, if possible, cooled before recovery.
- The recovery equipment must be in good working order, accompanied by a set of instructions at hand, and must be suitable for flammable refrigerant recovery. In addition, you will need to prepare a set of well-functioning calibrated scales.
- The pipes shall be complete with decoupling fittings that are leak-free and in good condition. Before using the recovery equipment, check that it is in good working order, that it has been properly maintained and that the associated electrical components are sealed to prevent a risk of ignition in the event of re-refrigerant leakage. If in doubt, consult the manufacturer.
- The recovered refrigerant must be returned to the supplier in the correct recovery cylinders, accompanied by the relevant waste identification form. Do not mix different types of refrigerant in recovery units, especially in cylinders.
- If compressors or compressor oils need to be decommissioned, evacuate them to an acceptable level to prevent flammable refrigerant from remaining inside the lubricant. The evacuation procedure must be carried out before returning the compressor to the suppliers. To accelerate this process, only use electric heating on the compressor body. When extracting oil from the system, drain it using a safe procedure.

## 11.20 Transport, marking and storage of units

---

### **Transport of equipment containing flammable refrigerants**

Follow applicable regulations related to transporting these materials.

### **Markings and signage on equipment**

Comply with current regulations.

### **Disposing of equipment containing flammable refrigerants**

Comply with current national regulations.

### **Equipment storage**

The equipment must be stored in accordance with the manufacturer's instructions.

### **Storage of packaged equipment (not sold)**

The packaging material to be stored must be protected so that any mechanical damage to the equipment contained in it cannot cause refrigerant leakage. The maximum number of appliances that can be stored in the same location is determined by local regulations.

Construction and specifications are subject to product improvement changes without notice. Please contact the sales agency or manufacturer for further details.

## 12. Maintenance

To ensure optimal availability of the unit, a series of checks and inspections must be carried out periodically on both the unit and the electrical connections. These maintenance procedures must be carried out by your local Bosch technician.



### ELECTROCUTION DANGER

- Before performing any maintenance or repair work, switch off the main power panel switch, remove the fuses (or switch off the circuit breakers) or open the unit's protection devices.
- Before starting any maintenance or repair work, make sure that the unit is switched off.
- After disconnecting the power supply, wait 10 minutes before touching live parts to avoid risks due to residual voltages in the DC bus condensers of the compressor inverter.
- Note that some sections of the electrical box are very hot. The same applies to the components of the high pressure refrigeration circuit. Consider the risk of burns and wear personal protective equipment before carrying out any work in these areas.
- Do not touch the conductive sections.
- Do not rinse the unit. Humidity can cause an electric shock or a fire risk.
- When removing the service panels, there is a risk of accidentally touching live components.
- When installing or servicing, never leave the unit unattended after removing the service panels.

The checks described should be carried out at least once a year by a qualified technician.	
Water pressure	Check that the water pressure is greater than 1 bar. If necessary, add water up to 1.5-1.8 bar.
Water filter	Check and clean the water filter.
Pressure relief valve	Check that the pressure relief valve is working properly by turning the black knob on the valve anticlockwise. <ul style="list-style-type: none"> <li>• If you do not hear a click, contact your local dealer.</li> <li>• If water continues to leak out of the unit, close the shut-off valves at the water inlet and outlet and contact your local dealer.</li> </ul>
Pressure relief valve pipe	Check that the pressure relief valve pipe is correctly positioned for draining the water.
Insulating backup heater cover	Check that the insulating cover of the built-in backup heater is tightly closed around the heater housing.
Domestic hot water storage tank pressure relief valve.	Only for installations with domestic hot water storage tank. Check that the pressure relief valve on the domestic hot water storage tank is working properly.
Domestic hot water storage tank booster heater.	Only for installations with domestic hot water storage tank. It is advisable to remove limescale build-up from the booster heater to prolong its life, especially in hard water areas. To do this, empty the domestic hot water storage tank, remove the booster heater from the storage tank and immerse it in a bucket (or other container) with limescale removal product for 24 hours.
Unit control box	Visually inspect the control box for any obvious defects, e.g. loose connections or faulty electrical connections. Check that the contactors are working properly with an ohmmeter. All contactor contacts must be in the open position.



<b>The checks described should be carried out at least once a year by a qualified technician.</b>	
Using glycol	<p>See chapter “6. Water connections” on page 36 “11.1 Controls in the area” on page 156.</p> <p>Document the glycol concentration and pH value of the system at least once a year.</p> <p>A pH value below 8.0 indicates that a significant proportion of the inhibitor has been consumed and should be topped up.</p> <p>A pH value of less than 7.0 indicates that the glycol has oxidised; in this case it is recommended to drain and flush the system thoroughly to prevent serious damage.</p> <p>The glycol solution must be disposed of in accordance with the local laws and regulations in force.</p>
Flow switch	Refer to the procedures given in chapter “6. Water connections” on page 36

## 13. Troubleshooting

This section contains useful information for diagnostics and correcting certain problems that may occur in the unit.  
Diagnostic procedures and associated corrective actions can only be carried out by the local technician.

### General guidelines

Before starting the troubleshooting procedure, visually inspect the unit for any obvious defects, e.g. loose connections or faulty electrical connections.



### WARNING

When inspecting the unit's control box, always make sure that the main switch is off.

If a safety device has been activated, shut down the unit and identify the cause before resetting it. Under no circumstances may safety devices be jumpered or adjusted to values different to the factory settings. If you cannot identify the cause of the problem, contact your local dealer.

If the pressure relief valve is not working properly and needs to be replaced, always reconnect the hose connected to the pressure relief valve to prevent water dripping from the unit while waiting for the replacement.

### NOTE

For problems related to the unit's optional kits, refer to the specific kit installation and operating manuals.

## 13.1 General problems

The unit is switched on but does not heat or cool as expected	
Possible causes	Corrective action
The set temperature is not correct	Check the setpoint of the control unit: <ul style="list-style-type: none"> <li>• T4HMAX, T4HMIN in Heating mode.</li> <li>• T4CMAX, T4CMIN in Cooling mode.</li> <li>• T4DHWMAX, T4DHWMIN in DHW mode.</li> </ul>
The water flow-rate is insufficient	<ul style="list-style-type: none"> <li>• Check that all shut-off valves in the water circuit are fully open.</li> <li>• Check that the water filter is clean.</li> <li>• Check that there is no air in the system (vent the system if necessary).</li> <li>• Check that the water pressure is sufficient on the pressure gauge. The water pressure must be &gt;1 bar (cold water).</li> <li>• Check that the expansion tank is intact.</li> <li>• Check that the resistance characteristic of the water circuit is not too high for the pump.</li> </ul>
The volume of water in the installation is insufficient	Check that the volume of water in the installation is greater than the minimum required value. See chapter "6. Water connections" on page 36. <ul style="list-style-type: none"> <li>- Checking the volume of water and precharge of the expansion tank.</li> </ul>
Unit in alarm	Check alarm code and report the problem to your local serviceman. A list of the alarms can be found in paragraph "10.4 Alarms" on page 150.

**The unit is switched on but the compressor does not start (for room heating or domestic hot water heating)**

Possible causes	Corrective action
The unit should start outside its operating range (the water temperature is too low)	<p>If the water temperature is low, the system first uses the backup heater to reach the minimum required temperature (12°C).</p> <ul style="list-style-type: none"> <li>• Check that the power supply to the backup heater is correct.</li> <li>• Check that the backup heater's thermal fuse is closed.</li> <li>• Check that the backup heater's thermal protection has not tripped.</li> <li>• Check that the backup heater's contactors are intact.</li> <li>• Be prepared with a backup heater if you think that cold starts may be frequent in these conditions (in case of long winter system shutdowns).</li> </ul>

**The pump is noisy (cavitation)**

Possible causes	Corrective action
The system contains air.	Vent the air
Insufficient pressure of water entering the pump	<ul style="list-style-type: none"> <li>• Check that the water pressure is sufficient on the pressure gauge. The water pressure must be &gt;1 bar (cold water).</li> <li>• Check that the pressure gauge is working properly.</li> <li>• Check that the expansion tank is intact.</li> <li>• Check that the expansion tank precharge is set correctly. See chapter "6. Water connections" on page 36. Checking the volume of water and precharge of the expansion tank</li> </ul>

**The water pressure relief valve opens**

Possible causes	Corrective action
Expansion tank is faulty	Replace the expansion tank.
The water filling pressure in the installation is greater than 0.30 MPa.	<p>Check that the water filling pressure in the installation is approx. 0.15 - 0.18 MPa. See chapter "6. Water connections" on page 36.</p> <p>Checking the volume of water and precharge of the expansion tank.</p> <p>If the pressure is higher, partially empty the circuit until the optimum range is reached.</p>

**The water pressure relief valve is leaking**

Possible causes	Corrective action
The water pressure relief valve outlet is obstructed.	<p>Check that the pressure relief valve is working properly by turning the red knob on the valve anticlockwise:</p> <ul style="list-style-type: none"> <li>• if you do not hear a click, contact your local dealer.</li> <li>• if water continues to leak out of the unit, close the shut-off valves at the water inlet and outlet and contact your local dealer.</li> </ul>

**The heat pump in DHW mode stops working but the setpoint is not reached, the room heating requires heat but the unit remains in DHW mode**

Possible causes	Corrective action
Coil surface in the tank not large enough	<ul style="list-style-type: none"> <li>• Set dT1s5 to 20 and set t_DHWHP_RESTRICT to the minimum value.</li> <li>• Set dT1SH to 2.</li> <li>• Enable TBH, TBH must be controlled by the unit.</li> <li>• If AHS (boiler) is available, enable it from the dip-switch also for DHW production.</li> <li>• If TBH and AHS are not available, try changing the position of the T5 probe.</li> </ul>

The heat pump in DHW mode stops working but the setpoint is not reached, the room heating requires heat but the unit remains in DHW mode	
Possible causes	Corrective action
TBH or AHS not available	The heat pump will remain in DHW mode until either t_DHWHP_MAX or the setpoint is reached. Add TBH or AHS for DHW mode, TBH and AHS must be controlled by the unit

Room heating is insufficient when the outdoor temperature is low	
Possible causes	Corrective action
The backup heater does not start.	<ul style="list-style-type: none"> <li>• Check that the “OTHER HEATING SOURCE/ BACKUP HEATER” option is enabled, see chapter “8.2.7 Additional heating source settings” on page 90 and paragraph “7.8 Dip-switch setting” on page 64.</li> <li>• Check that the backup heater's thermal protection has not tripped.</li> <li>• Check that the booster heater is not operating; the backup heater and booster heater cannot operate simultaneously.</li> <li>• Check fuses or safety thermostats in the case of an external backup heater and, if necessary, replace them after ascertaining the reason for the intervention.</li> </ul>
Too much heat pump capacity is used to heat domestic hot water (only for installations with domestic hot water storage tank).	<ul style="list-style-type: none"> <li>• Check that parameters “t_DHWHP_MAX” and “t_DHWHP_RESTRICT” are configured correctly.</li> <li>• Check that the 'DHW PRIORITY' function on the user interface is disabled.</li> <li>• Enable parameter “T4_TBH_ON” on the user interface/ FOR SERVICEMAN menu to start the booster heater for heating domestic hot water.</li> </ul>

It is not possible to switch immediately from heating mode to DHW mode	
Possible causes	Corrective action
The tank volume is too small and the position of the water temperature probe is not high enough	<ul style="list-style-type: none"> <li>• Set dT1s5 to 20 and set t_DHWHP_RESTRICT to the minimum value.</li> <li>• Set dT1SH to 2.</li> <li>• Enable TBH, TBH must be controlled by the unit.</li> <li>• If AHS (boiler) is available, switch on the boiler first, if the demand for the heat pump switched on is full, the heat pump will switch on.</li> <li>• If TBH and AHS are not available, try changing the position of the T5 probe.</li> </ul>



<b>It is not possible to switch immediately from DHW mode to heating mode</b>	
<b>Possible causes</b>	<b>Corrective action</b>
Heat exchanger for room heating is not large enough	<ul style="list-style-type: none"><li>• Set t_DHWHP_MAX to the minimum value, suggested value is 60min</li><li>• If the circulation pump outside the unit is not controlled by the unit, try connecting it to the unit.</li><li>• Add a 3-way valve to the inlet of the fan coil unit to ensure sufficient water flow.</li></ul>
The heating load in the room is reduced	<ul style="list-style-type: none"><li>• Normal, no need for heating.</li></ul>
The disinfect function is enabled but without TBH	<ul style="list-style-type: none"><li>• Disable the disinfect function.</li><li>• Add TBH or AHS for DHW mode.</li></ul>
Manual activation of the FAST WATER function, after the hot water fulfils the requirements, the heat pump does not switch to air conditioning mode	<ul style="list-style-type: none"><li>• Manual activation of the FAST WATER function.</li></ul>
The room temperature is low, AHS does not start.	<ul style="list-style-type: none"><li>• Set T4DHWMIN, suggested value <math>\geq -5^{\circ}\text{C}</math>.</li><li>• Set T4_TBH_ON, suggested value <math>\geq 5^{\circ}\text{C}</math>.</li></ul>
DHW Priority	<ul style="list-style-type: none"><li>• If AHS or IBH are present, when the unit is not operating, IBH or AHS must operate in DHW mode until the water temperature reaches the set temperature before switching to heating mode.</li></ul>

## 13.2 Error codes

When a safety device is activated, an error code is displayed on the user interface.

The following table contains a list of possible errors and their corrective actions.

Reset the safety device by switching the unit off and on again.

If the reset procedure fails, contact your local dealer.

Error code	Malfunctioning or protection	Cause of the problem and corrective action
CO	multiple units configured as master in the master - slave network	<ul style="list-style-type: none"> <li>• configure only one unit as master</li> </ul>
E0	Flow switch error (E8 displayed 3 times; to be seen together with E8).	<ul style="list-style-type: none"> <li>• The electric circuit has short-circuited or is open. Reconnect the wires correctly.</li> <li>• The water flow-rate is insufficient.</li> <li>• The flow switch is faulty. The switch opens or closes continuously. Replace the flow switch.</li> <li>• The system pressure losses are too high for the head of the unit's circulator. Overhaul the system.</li> </ul>
E1	Phase sequence error (only for three-phase units).	<ul style="list-style-type: none"> <li>• Check that the power cables are firmly connected to avoid phase losses.</li> <li>• Check the sequence of the power cables, change the sequence of any pair of the three power cables.</li> </ul>
E2	Communication error between the user interface and the main hydraulic module control board.	<ul style="list-style-type: none"> <li>• There is no connection between the wired control and the unit. Connect the wires.</li> <li>• The sequence of the communication wires is not correct. Reconnect the wires in the correct sequence.</li> <li>• There may be a strong magnetic field or electrical interference, e.g. from lifts, large transformers, etc. Add a barrier to protect the unit or move it to another location.</li> <li>• Check for possible interference from power cables along</li> </ul>
E3	Error of the backup heater's heat exchanger outlet T1 temperature sensor.	<ul style="list-style-type: none"> <li>• The T1 sensor connector is loose. Reconnect it.</li> <li>• The T1 sensor connector is wet or contains water. Expel the water and dry the connector. Apply a waterproof adhesive.</li> <li>• T1 sensor error, replace with a new sensor.</li> </ul>
E4	T5 DHW temperature sensor error	<ul style="list-style-type: none"> <li>• The T5 sensor connector is loose. Reconnect it.</li> <li>• The T5 sensor connector is wet or contains water. Expel the water and dry the connector. Apply a waterproof adhesive.</li> <li>• T5 sensor error, replace with a new sensor.</li> </ul>
E5	Error of the finned coil outlet T3 refrigerant temperature sensor in cooling mode.	<ul style="list-style-type: none"> <li>• The T3 sensor connector is loose. Reconnect it.</li> <li>• The T3 sensor connector is wet or contains water. Expel the water and dry the connector. Apply a waterproof adhesive.</li> <li>• T3 sensor error, replace with a new sensor.</li> </ul>
E6	T4 room temperature sensor error.	<ul style="list-style-type: none"> <li>• The T4 sensor connector is loose. Reconnect it.</li> <li>• The T4 sensor connector is wet or contains water. Expel the water and dry the connector. Apply a waterproof adhesive.</li> <li>• T4 sensor error, replace with a new sensor.</li> </ul>
E7	Tbt1 sensor error.	<ul style="list-style-type: none"> <li>• The Tbt1 sensor connector is loose. Reconnect it.</li> <li>• The Tbt1 sensor connector is wet or contains water. Expel the water and dry the connector. Apply a waterproof adhesive.</li> <li>• Tbt1 sensor error, replace it.</li> </ul>



Error code	Malfunctioning or protection	Cause of the problem and corrective action
E8	Water flow-rate error.	<p>Check that all shut-off valves in the water circuit are fully open.</p> <ul style="list-style-type: none"> <li>• Check that the water filter is clean.</li> <li>• See paragraph “6.7 Filling / topping up with water” on page 47.</li> <li>• Check that there is no air in the system; vent the system if necessary.</li> <li>• Check that the water pressure is sufficient on the pressure gauge. The water pressure must be &gt;1 bar.</li> <li>• Check that the pump speed is set to the maximum value.</li> <li>• Check that the expansion tank is intact.</li> <li>• Check that the resistance characteristic of the water circuit is not too high for the pump.</li> <li>• If this error occurs during the defrosting function (during room heating or domestic hot water heating), check that the power supply to the backup heater is connected correctly and the fuses have not blown.</li> <li>• Check that the pump fuse and the PCB fuse have not blown.</li> </ul>
E9	Th suction pipe sensor error.	<ul style="list-style-type: none"> <li>• The Th sensor connector is loose. Reconnect it.</li> <li>• The Th sensor connector is wet or contains water. Expel the water and dry the connector. Apply a waterproof adhesive.</li> <li>• Th sensor error, replace it.</li> </ul>
EA	Tp discharge temperature sensor error.	<ul style="list-style-type: none"> <li>• The Tp sensor connector is loose. Reconnect it.</li> <li>• The Tp sensor connector is wet or contains water. Expel the water and dry the connector. Apply a waterproof adhesive.</li> <li>• Tp sensor error, replace it.</li> </ul>
Eb	Solar panel sensor error (Tsolar).	<ul style="list-style-type: none"> <li>• The sensor connector is loose. Reconnect it.</li> <li>• The sensor connector is wet or contains water. Expel the water and dry the connector. Apply a waterproof adhesive.</li> <li>• Sensor error, replace it.</li> </ul>
Ed	Tw_in entering water temperature sensor error.	<ul style="list-style-type: none"> <li>• The Tw_in sensor connector is loose. Reconnect it.</li> <li>• The Tw_in sensor connector is wet or contains water. Expel the water and dry the connector. Apply a waterproof adhesive.</li> <li>• Tw_in sensor error, replace it.</li> </ul>
EE	EEPROM control board main hydraulic module control board failure.	<ul style="list-style-type: none"> <li>• EEPROM parameter error, rewrite EEPROM data.</li> <li>• EEPROM chips are faulty, replace with a new EEPROM.</li> <li>• Main hydraulic module control board is faulty, replace with a new PCB.</li> </ul>
bH	PED board error.	<ul style="list-style-type: none"> <li>• Switch off the power and switch on again after 5 minutes; check if everything is OK.</li> <li>• Replace the board, switch on again and check if everything is OK.</li> <li>• Replace the IPM module board.</li> </ul>
H0	Communication error between the main PCB B control board and the main hydraulic module control board.	<ul style="list-style-type: none"> <li>• The cable is disconnected between the main PCB B control board and the main hydraulic module control board. Connect the cable.</li> <li>• The sequence of the communication wires is not correct. Reconnect the wires in the correct sequence.</li> <li>• If there is a high magnetic field or high-power interference, e.g. lifts, large power transformers, etc. Add a barrier to protect the unit or move the unit to another location.</li> </ul>
H1	Communication error between PCB A inverter module and the main PCB B control board.	<ul style="list-style-type: none"> <li>• Check that the power supply is connected to the PCB and secondary board. Check whether the PCB indicator light is on or off. If it is switched off, reconnect the power cables.</li> <li>• If it is switched on, check the electrical connections between the main PCB and the secondary PCB. If the wire is loose or broken, reconnect it or replace it.</li> <li>• Replace the main PCB and the secondary board.</li> </ul>



Error code	Malfunctioning or protection	Cause of the problem and corrective action
H2	Error of the plate heat exchanger inlet temperature sensor (T2) on the refrigerant side in cooling mode.	<ul style="list-style-type: none"> <li>The T2 sensor connector is loose. Reconnect it.</li> <li>The T2 sensor connector is wet or contains water. Expel the water and dry the connector. Apply a waterproof adhesive.</li> <li>T2 sensor error, replace with a new sensor.</li> </ul>
H3	Error of the heat exchanger outlet temperature sensor (T2B) on the refrigerant side in cooling mode.	<ul style="list-style-type: none"> <li>The T2B sensor connector is loose. Reconnect it.</li> <li>The T2B sensor connector is wet or contains water. Expel the water and dry the connector. Apply a waterproof adhesive.</li> <li>T2B sensor error, replace with a new sensor.</li> </ul>
H4	Three P6 protection activations.	See P6.
H5	Ta internal temperature sensor error.	<ul style="list-style-type: none"> <li>Set the Ta sensor on the interface.</li> <li>If the Ta sensor is faulty, replace the sensor or interface.</li> </ul>
H6	DC fan error.	<ul style="list-style-type: none"> <li>The fan is exposed to a strong wind that causes it to operate in the opposite direction. Change the direction of operation of the unit or provide a guard to protect it from strong air currents.</li> <li>The fan motor is faulty, replace it.</li> </ul>
H7	Main circuit voltage fault.	<ul style="list-style-type: none"> <li>Check that the power supply values are within the available range.</li> <li>The unit has been switched on and off several times at close intervals. Keep the unit switched off for at least 3 minutes before switching it on again.</li> <li>Faulty circuit in the main control board. Replace the main PCB.</li> </ul>
H8	Pressure sensor error.	<ul style="list-style-type: none"> <li>The pressure sensor connector is loose. Reconnect it.</li> <li>The pressure sensor is faulty. Replace it.</li> </ul>
H9	Tw2 sensor error.	<ul style="list-style-type: none"> <li>The sensor connector is loose. Reconnect it.</li> <li>The sensor connector is wet or contains water. Expel the water and dry the connector. Apply a waterproof adhesive.</li> <li>Sensor error, replace it with a new sensor.</li> </ul>
HA	Error of the TW_out leaving water temperature sensor of the plate heat exchanger.	<ul style="list-style-type: none"> <li>The TW_out sensor connector is loose. Reconnect it.</li> <li>The TW_out sensor connector is wet or contains water. Expel the water and dry the connector. Apply a waterproof adhesive.</li> <li>The TW_out sensor is faulty. Replace it.</li> </ul>
Hb	PP protection trips 3 times and Tw_out <7°C.	see PP.
Hd	Communication error between master and slave units.	<ul style="list-style-type: none"> <li>wrong address.</li> <li>incorrect wiring.</li> <li>check board fuse.</li> <li>H1-H2 wiring.</li> </ul>
HE	Communication error between main board and thermostat.	The outdoor temperature is very high (above 30°C) but the unit is still operating in Heating mode. Disable the Heating mode when the room temperature exceeds 30°C.
HF	Inverter module EEPROM error.	<ul style="list-style-type: none"> <li>The EEPROM parameter is set incorrectly, rewrite the EEPROM data.</li> <li>The EEPROM chip is faulty, replace it.</li> <li>The main module is faulty, replace it.</li> </ul>
HH	H6 displayed 10 times in 2 hours.	See H6.
HL	PFC module fault.	Contact distributor.
HP	Low pressure protection (Pe < 0.6) tripped 3 times in one hour.	See P0.



Error code	Malfunctioning or protection	Cause of the problem and corrective action
P0	Low pressure protection.	<ul style="list-style-type: none"> <li>• There is no refrigerant in the system. Charge with refrigerant to the required volume.</li> <li>• In heating or hot water mode, the external heat exchanger is dirty or clogged. Clean the heat exchanger.</li> <li>• The water flow is low in cooling mode.</li> <li>• The electrical expansion valve is blocked or the winding connector is loose. Tap the valve body and insert/remove the connector several times to check that the valve is working properly. Install the winding in the correct position.</li> </ul>
P1	High pressure protection.	<p>Heating mode, domestic hot water mode:</p> <ul style="list-style-type: none"> <li>• The water flow-rate is low; the water temperature is high, check if there is air in the system. Expel the air.</li> <li>• The water pressure is less than 0.1 Mpa, fill with water to increase the pressure to 0.15-0.18 Mpa.</li> <li>• Increase the volume of refrigerant. Top up the refrigerant to the required volume.</li> <li>• The electrical expansion valve is blocked or the winding connector is loose. Tap the valve body and insert/remove the connector several times to check that the valve is working properly. Install the winding in the correct position.</li> </ul> <p>Domestic hot water mode:</p> <ul style="list-style-type: none"> <li>• The heat exchanger storage tank has an insufficient area. Increase parameter DT1s5 to 20 °C (DT DHW). Caution: this will lower the maximum setpoint that the unit can fulfil.</li> </ul> <p>Cooling mode:</p> <ul style="list-style-type: none"> <li>• The external heat exchanger cover is attached. Remove it.</li> <li>• The external heat exchanger is dirty or its surface is obstructed. Clean the heat exchanger or remove the obstruction.</li> <li>• Ensure that functional spaces and proper ventilation are respected. Check for ventilation faults during operation.</li> </ul>
P3	Compressor overcurrent protection.	<p>See P1.</p> <p>The unit's power supply voltage is low, increase it to the required value.</p>
P4	Protection for high discharge temperature.	<ul style="list-style-type: none"> <li>• See P1.</li> <li>• The volume of refrigerant in the system is insufficient, charge with the required volume.</li> <li>• The TW_out temperature sensor is loose. Reconnect it.</li> <li>• The T1 temperature sensor is loose. Reconnect it.</li> <li>• The T5 temperature sensor is loose. Reconnect it.</li> </ul>
P5	Protection against high temperature difference between entering and leaving water of the plate heat exchanger.	<ul style="list-style-type: none"> <li>• Check that all shut-off valves in the water circuit are fully open.</li> <li>• Check that the water filter is clean.</li> <li>• See paragraph <u>"6.7 Filling / topping up with water"</u> on page 47.</li> <li>• Check that there is no air in the system (vent the system if necessary).</li> <li>• Check that the water pressure is sufficient on the pressure gauge. The water pressure must be &gt;1 bar (cold water).</li> <li>• Check that the pump speed is set to the maximum value.</li> <li>• Check that the expansion tank is intact.</li> <li>• Check that the characteristic of the water circuit is not too high for the pump. See "START-UP AND CONFIGURATION - Pump speed control").</li> </ul>



Error code	Malfunctioning or protection	Cause of the problem and corrective action
P6	Module protection.	<ul style="list-style-type: none"> <li>• The unit's power supply voltage is low, increase it to the required value.</li> <li>• The space between the units is too narrow for heat exchange. Increase the space between units.</li> <li>• The heat exchanger is dirty or its surface is obstructed. Clean the heat exchanger or remove the obstruction.</li> <li>• The fan is not working. The fan motor is faulty, replace the fan or the motor.</li> <li>• Increase the volume of refrigerant. Top up the refrigerant to the required volume.</li> <li>• The water flow-rate is low, there is air in the system or the pump head is not sufficient. Expel the air and reset the pump.</li> <li>• The leaving water temperature sensor is loose or faulty, reconnect it or replace it.</li> <li>• The domestic hot water storage tank has coils that are not suitable for the power to be dissipated.</li> <li>• The wires or screws on the module are loose. Reconnect the wires and screws.</li> <li>• The heat-conducting adhesive is dry or detached. Add heat-conducting adhesive.</li> <li>• The wire connector is loose or detached. Reconnect the wire</li> <li>• The control board is defective, replace it.</li> <li>• If the control system is working properly, it means that the compressor is faulty</li> </ul>
P9	Fan protection.	Contact the Distributor
Pd	Protection for high refrigerant outlet temperature in the finned coil in cooling mode.	<ul style="list-style-type: none"> <li>• The heat exchanger cover is attached.</li> <li>• The heat exchanger is dirty or its surface is obstructed.</li> <li>• The space around the unit is not sufficient for heat exchange.</li> <li>• Review the installation.</li> <li>• The fan motor is faulty.</li> </ul>
Pb	Antifreeze protection.	The unit will automatically return to normal operation.
PP	The inlet water temperature is higher than the outlet water temperature in heating mode.	<ul style="list-style-type: none"> <li>• The inlet/outlet water sensor connector is loose.</li> <li>• The inlet sensor (TW_in) or outlet sensor (TW_out) is faulty.</li> <li>• The 4-way valve is blocked. Restart the unit to make the valve change direction.</li> <li>• The 4-way valve is faulty.</li> </ul>
F1	DC generatrix voltage too low.	<ul style="list-style-type: none"> <li>• Check power supply.</li> <li>• If the power supply is OK, check if the LED light is OK, check the PN voltage, if it is 380 V, the problem is with the main board. If the light is off, disconnect the power supply, check the IGBT, check the diodes, if the voltage is not correct, the inverter board is damaged, replace it.</li> <li>• If the IGBT is OK, which means the inverter board is OK, the rectifier bridge of the power module is not correct, check the bridge. Same method as for the IGBT, disconnect the power supply, check whether the diodes are damaged or not.</li> <li>• Usually if F1 trips when the compressor starts, the reason is possibly the motherboard. If F1 trips when the fan starts, it may be due to the inverter board.</li> </ul>



Error code	Malfunctioning or protection	Cause of the problem and corrective action
L0	Compressor inverter module fault.	<p>Check:</p> <ul style="list-style-type: none"><li>• 1. compressor working pressures.</li><li>• 2. compressor winding heaters.</li><li>• 3. U V W sequence between inverter board and compressor.</li><li>• 4. L1 L2 L3 sequence between inverter board and filter board.</li><li>• 5. inverter board.</li></ul>
L1	Low voltage BUS protection of the inverter module.	
L2	High voltage BUS protection of the inverter module.	
L4	MCE protection.	
L5	Speed 0 protection.	
L7	Phase sequence error.	
L8	Compressor frequency variation greater than 15 Hz in 1 sec.	
L9	Compressor frequency difference to target greater than 15 Hz.	